

EWP Product Guide

www.USPconnectors.com

For Use With Products Manufactured

by



Trus Joist™

A Weyerhaeuser Business

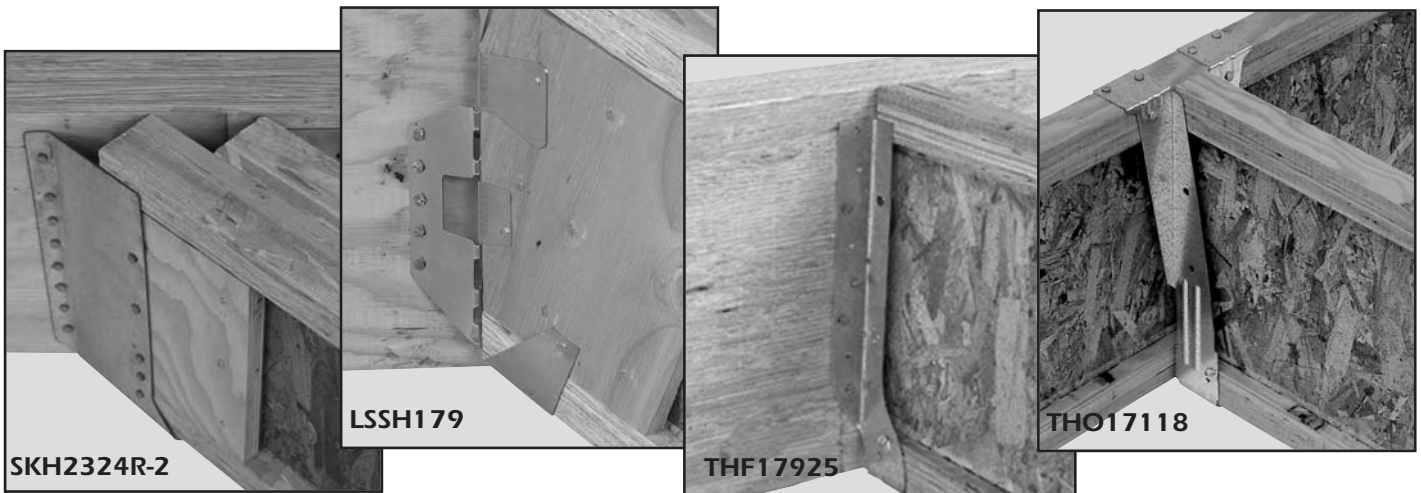

USP
Structural
Connectors™
A GIBRALTAR COMPANY
CELEBRATING 50 YEARS
1954 • 2004

**TJI® 110, 210, 230,
360, & 560 Joists**



USP supplies quality products to build Stronger Safer Structures _____
Rancho Cucamonga • Livermore • Montgomery • Houston • Largo • North Wilkesboro • Hainesport

Follow these instructions to ensure the proper installation of USP products.

General Notes

- 1) See current USP Full Line Catalog for General Notes, Warranty, and installation information for hanger models, joist sizes, and header situations not shown.
- 2) Loads listed address hanger/header/fastener limitations as well as joist/hanger limitations assuming header material is Douglas Fir-Larch (DF-L), Southern Pine (SP), or Microllam® LVL, Parallam® PSL, or TimberStrand® LSL. Joist reaction should be checked by a qualified designer to ensure proper hanger selection.
- 3) Uplift loads have been increased 33% for wind or seismic loads and no further increase shall be permitted. Reduce loads according to code for normal duration loading such as cantilever construction.
- 4) If hanger height is less than 60% of joist height, joist rotation may occur, therefore supplemental lateral restraints are required, see page 3.
- 5) The type and quantity of fasteners used to install USP products is critical to connector performance. To achieve the allowable loads shown in this catalog, install with the fasteners specified for that particular

- product. All specified fasteners must be properly installed prior to applying load of any kind to the connection.
- 6) Throughout this guide, dimensions are expressed in inches and loads in pounds, unless specifically noted otherwise.
- 7) Load values for 10d and 16d designations in the fastener schedules throughout this catalog refer to common wire nails, unless noted otherwise.
- 8) The allowable loads shown in this catalog are based on Allowable Stress Design methodology.
- 9) *Multiple TJI® Joist Plies:* Fasten together multiple plies of wood TJI® Joist's, in accordance with Trus Joist's installation guidelines, such that the joists act as a single unit.
- 10) *Sloped TJI® Joists:* Use sloped seat hangers and beveled web stiffeners whenever the slope exceeds the following: 1/2:12 for seat bearing lengths of 2 1/2" or less; 3/8:12 for bearing lengths between 2 1/2" and 3 1/2"; and 1/4:12 for bearing lengths in excess of 3 1/2".

Backer Blocks

Pattern the nails used to install backer blocks or web stiffeners in wood TJI® Joist's to avoid splitting the block. The nail pattern should be sufficiently spaced to avoid the same grain line, particularly with solid sawn backer blocks. Backer blocks must be installed on wood TJI® Joist's acting as the header, or supporting member. Install in accordance with the Trus Joist's installation guidelines. The nails used to install hangers mounted to a TJI® Joist header must penetrate through the web and into the backer block on the opposite side.

Filler Block Installation: Nail with ten 10d (3") box nails, clinched. Use ten 16d (3 1/2") box nails from each side with TJI® 560 joists.

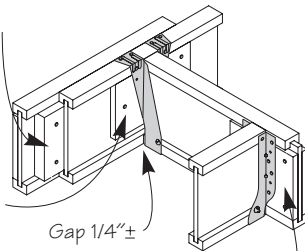

Backer Block Installation: Install tight to top flange (tight to bottom flange with face mount hangers). Attach with ten 10d (3") box nails, clinched when possible.

Backer Block (both sides) of web with single TJI® Joist.

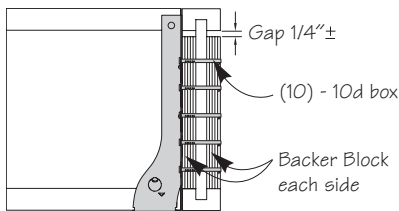

With top flange hangers, backer block required only for downward loads exceeding 250 lbs or for uplift conditions

Filler and Backer Block sizes

TJI® Depth	110		210		230 or 360		560	
	9-1/2" or 11-7/8"	14"	9-1/2" or 11-7/8"	14" or 16"	9-1/2" or 11-7/8"	14" or 16"	11-7/8"	14" or 16"
Filler Block*	2x6	2x8	2x6 + 3/8" sheathing	2x8 + 3/8" sheathing	2x6 + 1/2" sheathing	2x8 + 1/2" sheathing	Two 2x6	Two 2x8
Cantilever Filler	2x6 4'-0" long	2x10 6'-0" long	2x6 + 3/8" sheathing 4'-0" long	2x10 + 3/8" sheathing 6'-0" long	2x6 + 1/2" sheathing 4'-0" long	2x10 + 1/2" sheathing 6'-0" long	Not applicable	
Backer Block*	5/8"	5/8"	3/4"	3/4"	1" net	1" net	2x6	2x8

*If necessary, increase filler and backer block height for face mount hangers. Maintain 1/8" gap at top of joist; see web stiffener attachment details. Filler and backer block dimensions should accommodate required nailing without splitting.

Typical THF backer block installation

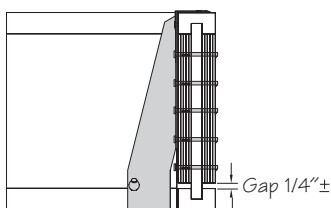

Typical THO backer block installation

Web Stiffener Attachment for TJI® Joists

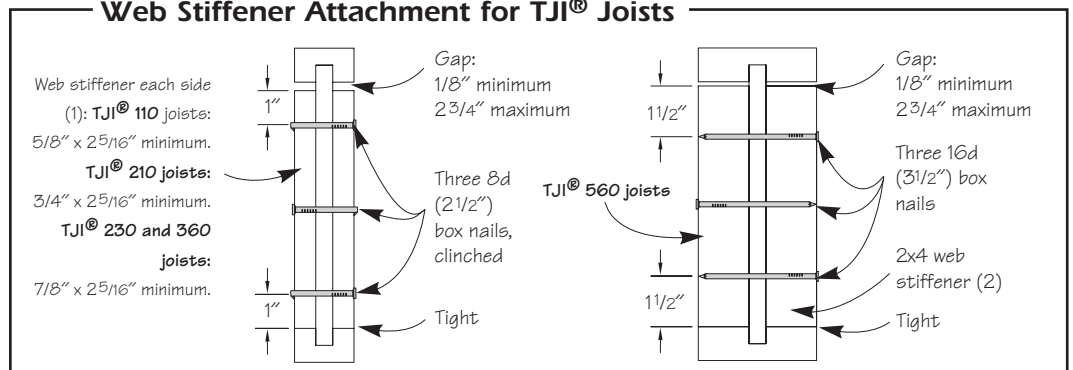

Support Height & Lateral Stability

Hangers for joists **without web stiffeners** must support the TJI® Joist's top flange and provide lateral resistance with no more than 1/8" horizontal deflection.

Hangers for joists **with web stiffeners** must support a minimum of 60% of joist depth.

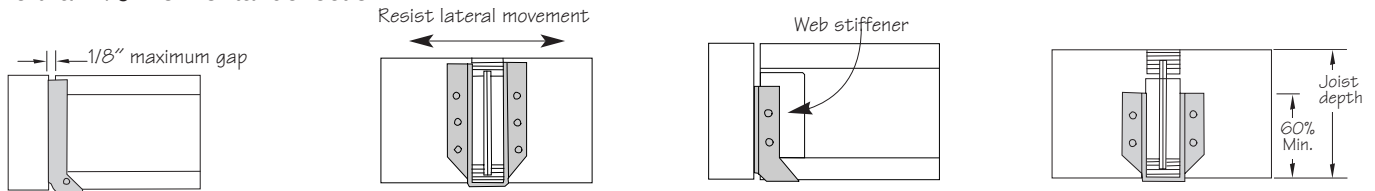

(Top flange support requirements can be verified in *EWP Top Mount Hangers* charts under the *Web Stiffener Req.* column of USP's *Full Line Catalog*.)

Nailer Installations

Correct Hanger Attachment to Nailer

A nailer or sill plate is considered to be any wood member attached to a steel beam, concrete block wall, concrete stem wall, or other structure unsuitable for nailing, which is used as a nailing surface for top mount hangers to hold beams or joists.

Nailer Sized Correctly

Top flange of hanger is fully supported and recommended nails have full penetration into nailer, resulting in a carried member hanging safely at the proper height.

The nailer must be sized to fit the support width as shown and be of sufficient thickness to satisfy recommended top flange nailing requirements. A design professional must specify nailer attachment to steel beams.

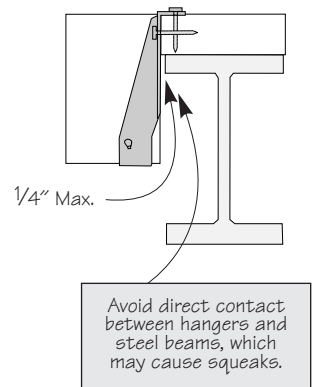

Wrong Nailer Size Causes Component Failure

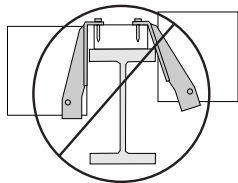

Too Narrow

Top flange not fully supported can cause nail breakout. Or, by fully supporting top flange, hanger is tilted back, causing lifting of carried member which results in uneven surfaces and squeaky floors.

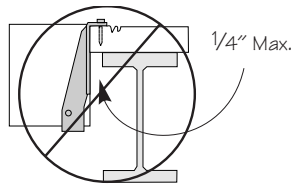

Too Wide

Loading can cause cross grain breaking of nailer. The recommended nailer overhang is 1/4" maximum per side.

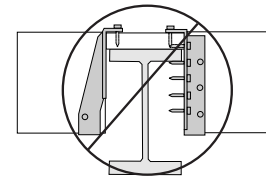

Too Thin

Top flange nailing cannot fully penetrate nailer, causing reduced allowable loads. Never use hangers which require multiple face nails since the allowable loads are dependent on all nail holes being used.

Top Flange Hangers

The thickness of the hanger metal and nail heads on top mount hangers must be evaluated for the effect on subsequent sheathing. Ensure the top mount hanger is installed so the flanges of the hanger are not *over-spread* which tends to elevate the supported TJI® Joist, causing uneven floor surfaces and squeaking. Similarly, ensure the hanger is installed plumb such that the face flanges of the hanger are mounted firmly against the wide-face surface of the header.

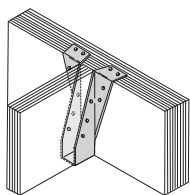

Flush framing

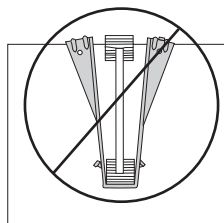

Hanger over-spread

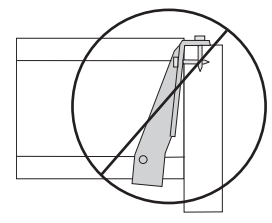

Hanger not plumb

Single TJI® Joists

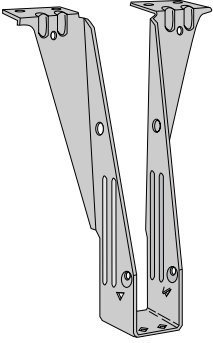

THO

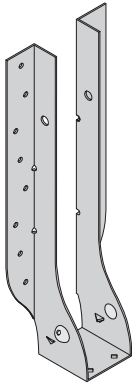

THF

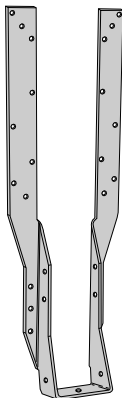

MSH

Joist Height	Top Mount Hangers ⁴						Face Mount Hangers					
	USP Stock No. ^{1,6}	Fastener Schedule ⁵		Uplift ³		Down 100% ²	USP Stock No. ^{1,6}	Fastener Schedule ⁵		Uplift ³		Down 100% ²
		Header	Joist	133%	160%			Header	Joist	133%	160%	
TJI® 110 Joist Width = 1-3/4"												
9-1/2	THO17950	(6) 10d	(2) 10d x 1-1/2	245	245	935	THF17925	(8) 10d	(2) 10d x 1-1/2	245	280	895
11-7/8	THO17118	(6) 10d	(2) 10d x 1-1/2	245	245	950	THF17112	(8) 10d	(2) 10d x 1-1/2	245	280	895
14	THO17140	(10) 10d	(2) 10d x 1-1/2	230	230	1215	THF17140	(12) 10d	(2) 10d x 1-1/2	245	280	950
TJI® 210 Joist Width = 2-1/16"												
9-1/2	THO20950	(6) 10d	(2) 10d x 1-1/2	230	230	1030	THF20925	(8) 10d	(2) 10d x 1-1/2	245	280	895
11-7/8	THO20118	(6) 10d	(2) 10d x 1-1/2	230	230	1030	THF20112	(8) 10d	(2) 10d x 1-1/2	245	280	895
14	THO20140	(10) 10d	(2) 10d x 1-1/2	230	230	1080	THF20140	(12) 10d	(2) 10d x 1-1/2	245	280	1045
16	THO20160	(10) 10d	(2) 10d x 1-1/2	230	230	1080	THF20157	(24) 10d	(2) 10d x 1-1/2	245	280	1045
TJI® 230 Joist Width = 2-5/16"												
9-1/2	THO23950	(10) 10d	(2) 10d x 1-1/2	245	295	1140	THF23925	(12) 10d	(2) 10d x 1-1/2	175	175	1160
11-7/8	THO23118	(10) 10d	(2) 10d x 1-1/2	245	295	1185	THF23118	(14) 10d	(2) 10d x 1-1/2	175	175	1215
14	THO23140	(12) 10d	(2) 10d x 1-1/2	245	265	1185	THF23140	(18) 10d	(2) 10d x 1-1/2	175	175	1215
16	THO23160	(12) 10d	(2) 10d x 1-1/2	245	265	1185	THF23160	(22) 10d	(2) 10d x 1-1/2	245	295	1215
TJI® 360 Joist Width = 2-5/16"												
11-7/8	THO23118	(10) 10d	(2) 10d x 1-1/2	245	295	1230	THF23118	(14) 10d	(2) 10d x 1-1/2	175	175	1260
14	THO23140	(12) 10d	(2) 10d x 1-1/2	245	265	1230	THF23140	(18) 10d	(2) 10d x 1-1/2	175	175	1260
16	THO23160	(12) 10d	(2) 10d x 1-1/2	245	265	1230	THF23160	(22) 10d	(2) 10d x 1-1/2	245	295	1260
TJI® 560 Joist Width = 3-1/2"												
11-7/8	THO35118	(10) 10d	(2) 10d x 1-1/2	245	295	1430	THF35112	(16) 10d	(2) 10d x 1-1/2	245	245	1460
14	THO35140	(12) 10d	(2) 10d x 1-1/2	245	265	1430	THF35140	(20) 10d	(2) 10d x 1-1/2	245	245	1460
16	THO35160	(12) 10d	(2) 10d x 1-1/2	245	265	1430	THF35157	(22) 10d	(2) 10d x 1-1/2	245	245	1460

- 1) Web stiffeners may be required for hangers by Trus Joist.
- 2) Loads listed are based on hanger attachment to a DF-L or SP species solid sawn, TJI® Joist or Microllam® LVL, Parallam® PSL, or TimberStrand® LSL header. Contact your local Trus Joist or USP Structural Connectors Technical Representative for additional duration of load values.
- 3) Uplift loads have been increased 33% or 60% for wind and seismic loading; no further increase shall be permitted.
- 4) Top Mount Hangers require minimum 3" header width for THO series hangers; 3-1/2" minimum header thickness for all other stock numbers.
- 5) 10d x 1-1/2" nails are 9 gauge (0.148" diameter) by 1-1/2" long.
 10d and 16d nails are common wire and require a minimum penetration of 1-3/4" and 1-15/16" respectively.
 16d sinkers (0.148" diameter) by 3-1/4" long may be substituted for 10d common nails with no load reduction.
- 6) For additional sizes, stock numbers, and modifications not shown, refer to USP's Full Line Catalog.

Single TJI® Joists

Joist Height	Adjustable Height						Field Slope & Skew						Skewed 45° Hangers					
	USP Stock No. ^{1,6}	Fastener Schedule ⁴		Uplift ³		Down 100% ²	USP Stock No. ^{1,6}	Fastener Schedule ^{4,7}		Uplift ³		Down 100% ²	USP Stock No. ^{1,6}	Fastener Schedule ^{4,7}		Uplift ³		Down 100% ²
		Header	Joist	133%	160%			Header	Joist	133%	160%			Header	Joist	133%	160%	
TJI® 110 Joist Width = 1-3/4"																		
9-1/2	---	---	---	---	---	LSSH179	(10) 10d	(7) 10d x 1-1/2	475	570	1120	SKH1720L/R	(14) 10d	(10) 10d x 1-1/2	475	570	910	
11-7/8	MSH1718	(6) 10d	(4) 10d x 1-1/2	---	---	885	LSSH179	(10) 10d	(7) 10d x 1-1/2	475	570	1120	SKH1720L/R	(14) 10d	(10) 10d x 1-1/2	475	570	920
14	MSH1722	(6) 10d	(4) 10d x 1-1/2	---	---	885	LSSH179	(10) 10d	(7) 10d x 1-1/2	475	570	1120	SKH1720L/R	(14) 10d	(10) 10d x 1-1/2	475	570	920
TJI® 210 Joist Width = 2-1/16"																		
9-1/2	See current USP Full Line Catalog or Trus Joist software for specialty hanger options						LSSH20	(10) 10d	(7) 10d x 1-1/2	475	570	1120	SKH2020L/R	(14) 10d	(10) 10d x 1-1/2	475	570	1005
11-7/8							LSSH20	(10) 10d	(7) 10d x 1-1/2	475	570	1120	SKH2020L/R	(14) 10d	(10) 10d x 1-1/2	475	570	1015
14							LSSH20	(10) 10d	(7) 10d x 1-1/2	475	570	1120	SKH2020L/R	(14) 10d	(10) 10d x 1-1/2	475	570	1015
16							LSSH20 ⁸	(10) 10d	(7) 10d x 1-1/2	475	570	1120	SKH2024L/R	(16) 10d	(10) 10d x 1-1/2	475	570	1015
TJI® 230 Joist Width = 2-5/16"																		
9-1/2	---	---	---	---	---	LSSH23	(10) 10d	(7) 10d x 1-1/2	475	570	1120	SKH2320L/R	(14) 10d	(10) 10d x 1-1/2	475	570	1055	
11-7/8	MSH2318	(6) 10d	(4) 10d x 1-1/2	---	---	1035	LSSH23	(10) 10d	(7) 10d x 1-1/2	475	570	1120	SKH2320L/R	(14) 10d	(10) 10d x 1-1/2	475	570	1065
14	MSH2318	(6) 10d	(4) 10d x 1-1/2	---	---	1035	LSSH23	(10) 10d	(7) 10d x 1-1/2	475	570	1120	SKH2324L/R	(16) 10d	(10) 10d x 1-1/2	475	570	1065
16	MSH2322	(6) 10d	(4) 10d x 1-1/2	---	---	1035	LSSH23 ⁸	(10) 10d	(7) 10d x 1-1/2	475	570	1120	SKH2324L/R	(16) 10d	(10) 10d x 1-1/2	475	570	1065
TJI® 360 Joist Width = 2-5/16"																		
11-7/8	MSH2318	(6) 10d	(4) 10d x 1-1/2	---	---	1080	LSSH23	(10) 10d	(7) 10d x 1-1/2	475	570	1120	SKH2320L/R	(14) 10d	(10) 10d x 1-1/2	475	570	1110
14	MSH2318	(6) 10d	(4) 10d x 1-1/2	---	---	1080	LSSH23	(10) 10d	(7) 10d x 1-1/2	475	570	1120	SKH2324L/R	(16) 10d	(10) 10d x 1-1/2	475	570	1110
16	MSH2322	(6) 10d	(4) 10d x 1-1/2	---	---	1080	LSSH23 ⁸	(10) 10d	(7) 10d x 1-1/2	475	570	1120	SKH2324L/R	(16) 10d	(10) 10d x 1-1/2	475	570	1110
TJI® 560 Joist Width = 3-1/2"																		
11-7/8	MSH422	(6) 10d	(6) 10d	---	---	1265	LSSH35	(14) 16d	(12) 10d x 1-1/2	475	570	1595	SKH410L/R ⁵	(16) 16d	(10) 10d	475	570	1460
14	See current USP Full Line Catalog or Trus Joist software for specialty hanger options						LSSH35	(14) 16d	(12) 10d x 1-1/2	475	570	1595	SKH414L/R ⁵	(22) 16d	(10) 10d	475	570	1460
16							LSSH35 ⁸	(14) 16d	(12) 10d x 1-1/2	475	570	1595	SKH414L/R ⁵	(22) 16d	(10) 10d	475	570	1460

- 1) Shaded hangers require web stiffeners at joist ends. Web stiffeners may be required for non-shaded hangers by Trus Joist.
- 2) Loads listed are based on hanger attachment to a DF-L or SP species solid sawn, Microllam® LVL, Parallam® PSL, or TimberStrand® LSL header. Contact your local Trus Joist or USP Structural Connectors Technical Representative for additional duration of load values.
- 3) Uplift loads have been increased 33% or 60% for wind and seismic loading; no further increase shall be permitted.
- 4) 10d x 1-1/2" nails are 9 gauge (0.148" diameter) by 1-1/2" long.
10d nails are common wire and require a minimum penetration of 1-3/4" and 1-15/16" respectively.
- 5) Miter cut required on end of joist to achieve design loads.
- 6) For additional sizes, stock numbers, and modifications not shown, refer to USP's Full Line Catalog.
- 7) Hangers utilizing 16d nails are not compatible with TJI® joist headers.
- 8) LSTA24 strap required along top chord for lateral restraint.

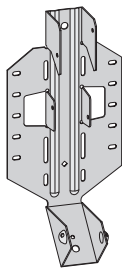

LSSH

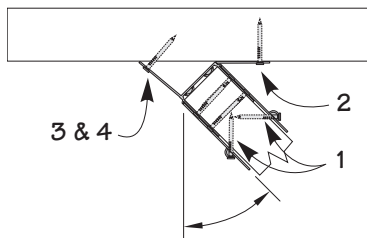

skew to 45° maximum

LSSH Installation:

- Use all specified fasteners.

Steps:

1. Position LSSH connector against plumb-cut end of joist. Fasten joist side flanges on both sides with 10d x 1-1/2" nails. Bend seat up to fit against joist bottom and drive (1) 10d x 1-1/2" nail through bottom seat into rafter bottom. Drive (2) 10d x 1-1/2" nails at downward angle through dimpled nailing guides.
2. Lean connector and rafter end against ridge beam at desired position. Install 10d or 16d nails through nail holes into ridge beam at right 90° angle. If skewing the rafter, only drive nails into ridge beam on inside flange.
3. Bend flange to desired angle.
4. Hammer outside flange until edge touches header. Fasten outside flange to ridge by driving 10d or 16d nails through nail holes.

- Web stiffeners are required for all wood I-Joist installations.
- Designer may consider adding a tension restraint for the supported member for roof slopes exceeding 6/12.

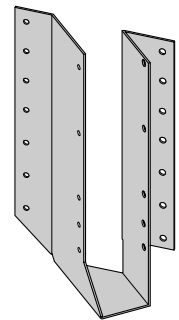

SKH_R
(right shown)

Double TJI® Joists

Joist Height	Top Mount Hangers ⁴						Face Mount Hangers						Skewed 45° Hangers																								
	USP Stock No. ^{1,6}	Fastener Schedule ^{5,9}		Uplift ³		Down 100% ²	USP Stock No. ^{1,6}	Fastener Schedule ^{5,9}		Uplift ³		Down 100% ²	USP Stock No. ^{1,6}	Fastener Schedule ^{5,9}		Uplift ³		Down 100% ²																			
		Header	Joist	133%	160%			Header	Joist	133%	160%			Header	Joist	133%	160%																				
Double TJI® 110																			Joist Width = 3-1/2"																		
9-1/2	THO35950	(10) 10d	(2) 10d x 1-1/2	245	295	2010	THF17925-2	(12) 10d	(6) 10d	475	570	1350	SKH410L/R ⁷	(16) 16d	(10) 16d	475	570	2060																			
11-7/8	THO35118	(10) 10d	(2) 10d x 1-1/2	245	295	2050	THF17112-2	(14) 10d	(6) 10d	475	570	1575	SKH410L/R ⁷	(16) 16d	(10) 16d	475	570	2170																			
14	THO35140	(12) 10d	(2) 10d x 1-1/2	245	265	2100	THF17140-2	(20) 10d	(6) 10d	475	570	2170	SKH410L/R ⁷	(16) 16d	(10) 16d	475	570	2170																			
Double TJI® 210																			Joist Width = 4-1/8"																		
9-1/2	THO20950-2	(10) 16d	(6) 10d	475	570	2330	THF20925-2	(12) 10d	(6) 10d	475	570	1350	SKH2020L/R-2	(14) 10d	(10) 10d	475	570	1610																			
11-7/8	THO20118-2	(10) 16d	(6) 10d	475	570	2610	THF20112-2	(16) 10d	(6) 10d	475	570	1575	SKH2020L/R-2	(14) 10d	(10) 10d	475	570	1610																			
14	THO20140-2	(12) 16d	(6) 10d	475	570	2330	THF20140-2	(20) 10d	(6) 10d	475	570	2250	SKH2024L/R-2	(16) 10d	(10) 10d	475	570	1840																			
16	THO20160-2	(12) 16d	(6) 10d	475	570	2330	-- --	-- --	-- --	-- --	-- --	-- --	SKH2024L/R-2	(16) 10d	(10) 10d	475	570	1840																			
Double TJI® 230																			Joist Width = 4-5/8"																		
9-1/2	THO23950-2	(10) 16d	(6) 10d	475	570	2490	THF23925-2	(14) 10d	(6) 10d	475	570	1575	SKH2320L/R-2	(14) 10d	(10) 10d	475	570	1610																			
11-7/8	THO23118-2	(10) 16d	(6) 10d	475	570	2675	THF23118-2	(16) 10d	(6) 10d	475	570	1800	SKH2320L/R-2	(14) 10d	(10) 10d	475	570	1610																			
14	THO23140-2	(12) 16d	(6) 10d	475	570	2675	THF23140-2	(20) 10d	(6) 10d	475	570	2370	SKH2324L/R-2	(16) 10d	(10) 10d	475	570	1840																			
16	THO23160-2	(12) 16d	(6) 10d	475	570	2675	THF23160-2	(24) 10d	(6) 10d	475	570	2430	SKH2324L/R-2	(16) 10d	(10) 10d	475	570	1840																			
Double TJI® 360																			Joist Width = 4-5/8"																		
11-7/8	THO23118-2	(10) 16d	(6) 10d	475	570	2765	THF23118-2	(16) 10d	(6) 10d	475	570	1800	SKH2320L/R-2	(14) 10d	(10) 10d	475	570	1610																			
14	THO23140-2	(12) 16d	(6) 10d	475	570	2765	THF23140-2	(20) 10d	(6) 10d	475	570	2370	SKH2324L/R-2	(16) 10d	(10) 10d	475	570	1840																			
16	THO23160-2	(12) 16d	(6) 10d	475	570	2765	THF23160-2	(24) 10d	(6) 10d	475	570	2520	SKH2324L/R-2	(16) 10d	(10) 10d	475	570	1840																			
Double TJI® 560																			Joist Width = 7"																		
11-7/8	BPH71118	(10) 16d	(6) 10d	475	570	3185	HD7120	(16) 16d	(6) 10d	475	570	2175	HD7120-SK45L/R ^{7,8}	(16) 16d	(6) 10d	475	570	2175																			
14	BPH71114	(10) 16d	(6) 10d	475	570	3185	HD7140	(20) 16d	(8) 10d	475	570	2720	HD7140-SK45L/R ^{7,8}	(20) 16d	(8) 10d	475	570	2720																			
16	BPH71116	(10) 16d	(6) 10d	475	570	3185	HD7160	(24) 16d	(8) 10d	475	570	2925	HD7160-SK45L/R ^{7,8}	(24) 16d	(8) 10d	475	570	3265																			

- 1) Shaded hangers require web stiffeners at joist ends. Web stiffeners may be required for non-shaded hangers by Trus Joist.
- 2) Loads listed are based on hanger attachment to a DF-L or SP species solid sawn, Microllam® LVL, Parallam® PSL, or TimberStrand® LSL header. Contact your local Trus Joist or USP Structural Connectors Technical Representative for additional duration of load values.
- 3) Uplift loads have been increased 33% or 60% for wind and seismic loading; no further increase shall be permitted.
- 4) Top Mount Hangers require minimum 3" header width for THO series hangers; 3-1/2" minimum header thickness for all other stock numbers.
- 5) 10d x 1-1/2" nails are 9 gauge (0.148" diameter) by 1-1/2" long.
 10d and 16d nails are common wire and require a minimum penetration of 1-3/4" and 1-15/16" respectively.
 16d sinkers (0.148" diameter) by 3-1/4" long may be substituted for 10d common nails with no load reduction.
- 6) For additional sizes, stock numbers, and modifications not shown, refer to USP's Full Line Catalog.
- 7) Miter cut required on end of joist to achieve design loads.
- 8) Hangers are special order. Consult USP for pricing and lead times.
- 9) Hangers utilizing 16d nails are not compatible with TJI® joist headers.

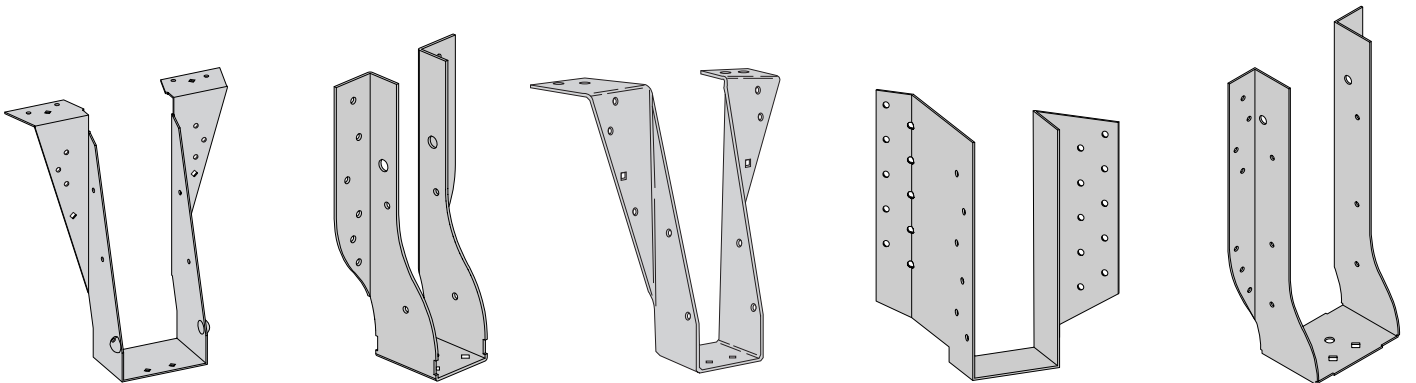

THO-Double

HD-Double

BPH

SKH_R-Double
(right shown)

THF-Double

Double TJI® Joists

Joist Height	Adjustable Height						Slope & Skew					
	USP Stock No. ^{1,5}	Fastener Schedule ^{4,7}		Uplift ³		Down 100% ²	USP Stock No. ^{1,5}	Fastener Schedule ^{4,7}		Uplift ³		Down 100% ²
		Header	Joist	133%	160%			Header	Joist	133%	160%	
Double TJI® 110 Joist Width = 3-1/2"												
9-1/2	MSH422	(6) 10d	(6) 10d	--	--	2025	LSSH35	(14) 16d	(12) 10d x 1-1/2	475	570	1885
11-7/8	MSH422	(6) 10d	(6) 10d	--	--	2025	LSSH35	(14) 16d	(12) 10d x 1-1/2	475	570	1885
14	--	--	--	--	--	--	LSSH35	(14) 16d	(12) 10d x 1-1/2	475	570	1885
Double TJI® 210 Joist Width = 4-1/8"												
9-1/2	See current USP Full Line Catalog or Trus Joist software for specialty hanger options						See current USP Full Line Catalog or Trus Joist software for specialty hanger options					
11-7/8												
14												
16												
Double TJI® 230 Joist Width = 4-5/8"												
9-1/2	MSH2322-2 ⁶	(6) 10d	(4) 10d	--	--	2210	See current USP Full Line Catalog or Trus Joist software for specialty hanger options					
11-7/8	MSH2322-2 ⁶	(6) 10d	(4) 10d	--	--	2210						
14	MSH2322-2 ⁶	(6) 10d	(4) 10d	--	--	2210						
16	--	--	--	--	--	--						
Double TJI® 360 Joist Width = 4-5/8"												
11-7/8	MSH2322-2 ⁶	(6) 10d	(4) 10d	--	--	2160	See current USP Full Line Catalog or Trus Joist software for specialty hanger options					
14	MSH2322-2 ⁶	(6) 10d	(4) 10d	--	--	2160						
16	--	--	--	--	--	--						
Double TJI® 560 Joist Width = 7"												
11-7/8	MSH422-2	(8) 16d	(6) 16d	--	--	2530	See current USP Full Line Catalog or Trus Joist software for specialty hanger options					
14	See current USP Full Line Catalog or Trus Joist software for specialty hanger options											
16												

- 1) Shaded hangers require web stiffeners at joist ends. Web stiffeners may be required for non-shaded hangers by Trus Joist.
- 2) Loads listed are based on hanger attachment to a DF-L or SP species solid sawn, Microllam® LVL, Parallam® PSL, or TimberStrand® LSL header. Contact your local Trus Joist or USP Structural Connectors Technical Representative for additional duration of load values.
- 3) Uplift loads have been increased 33% or 60% for wind and seismic loading; no further increase shall be permitted.
- 4) 10d x 1-1/2" nails are 9 gauge (0.148" diameter) by 1-1/2" long.
10d and 16d nails are common wire and require a minimum penetration of 1-3/4" and 1-15/16" respectively.
16d sinkers (0.148" diameter) by 3-1/4" long may be substituted for 10d common nails with no load reduction.
- 5) For additional sizes, stock numbers, and modifications not shown, refer to USP's Full Line Catalog.
- 6) Hangers are special order. Consult USP for pricing and lead times.
- 7) Hangers utilizing 16d nails are not compatible with TJI® joist headers.
- 8) LSTA24 strap required along top chord for lateral restraint.

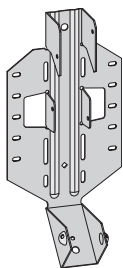

LSSH

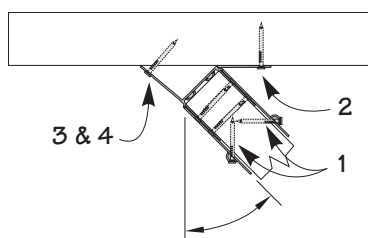

skew to 45° maximum

LSSH Installation:

- Use all specified fasteners.

Steps:

1. Position LSSH connector against plumb-cut end of joist. Fasten joist side flanges on both sides with 10d x 1-1/2" nails. Bend seat up to fit against joist bottom and drive (1) 10d x 1-1/2" nail through bottom seat into rafter bottom. Drive (2) 10d x 1-1/2" nails at downward angle through dimpled nailing guides.
2. Lean connector and rafter end against ridge beam at desired position. Install 10d or 16d nails through nail holes into ridge beam at right 90° angle. If skewing the rafter, only drive nails into ridge beam on inside flange.
3. Bend flange to desired angle.
4. Hammer outside flange until edge touches header. Fasten outside flange to ridge by driving 10d or 16d nails through nail holes.

- Web stiffeners are required for all wood I-Joist installations.
- Designer may consider adding a tension restraint for the supported member for roof slopes exceeding 6/12.

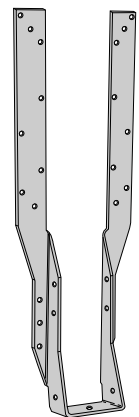

MSH

Microllam® LVL, Parallam® PSL or Timberstrand® LSL Beams & Headers

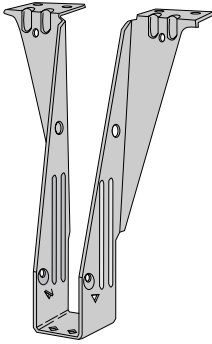

THO

Joist Height	USP Stock No. ⁶	Top Mount Hangers ³							Face Mount Hangers						
		Fastener Schedule ⁴		Uplift ²		Down 100% ¹			USP Stock No. ⁶	Fastener Schedule ⁴		Uplift ²		Down 100% ¹	
		Header	Joist	133%	160%	Header Material				Header	Joist	133%	160%	Header Material	
						LVL	PSL	LSL						LVL	DF-L/SP
1-3/4" Microllam® LVL or Parallam® PSL or Timberstrand® LSL															
7-1/4	PHXU17725	(8) 16d	(6) 10d x 1-1/2	800	960	4155	4155	4155	-- --	-- --	-- --	-- --	-- --	-- --	
9-1/4	THO17925	(6) 10d	(2) 10d x 1-1/2	230	230	1345	1290	1335	HD17925	(18) 16d	(6) 10d x 1-1/2	770	920	2450	
	PHXU17925	(8) 16d	(6) 10d x 1-1/2	800	960	4155	4155	4155	HUS179 ⁵	(30) 16d	(10) 16d	3205	3205	4890	
9-1/2	THO17950	(6) 10d	(2) 10d x 1-1/2	245	245	1345	1290	1335	HD17925	(18) 16d	(6) 10d x 1-1/2	770	920	2450	
	PHXU1795	(8) 16d	(6) 10d x 1-1/2	800	960	4155	4155	4155	HUS179 ⁵	(30) 16d	(10) 16d	3205	3205	4890	
11-1/4	THO17112	(6) 10d	(2) 10d x 1-1/2	230	230	1345	1290	1335	HD17112	(22) 16d	(6) 10d x 1-1/2	770	920	2765	
	PHXU17112	(8) 16d	(6) 10d x 1-1/2	800	960	4155	4155	4155	HUS179 ⁵	(30) 16d	(10) 16d	3205	3205	4890	
11-7/8	THO17118	(6) 10d	(2) 10d x 1-1/2	245	245	1345	1290	1335	HD17112	(22) 16d	(6) 10d x 1-1/2	770	920	2765	
	PHXU17118	(8) 16d	(6) 10d x 1-1/2	800	960	4155	4155	4155	HUS179 ⁵	(30) 16d	(10) 16d	3205	3205	4890	
14	THO17140	(10) 10d	(2) 10d x 1-1/2	230	230	1760	1760	1760	HD1714	(26) 16d	(8) 10d x 1-1/2	1025	1065	2955	
	PHXU1714	(8) 16d	(6) 10d x 1-1/2	800	960	4155	4155	4155	HUS179 ⁵	(30) 16d	(10) 16d	3205	3205	4890	
2-11/16" Parallam® PSL															
9-1/4	PHXU27925	(8) 16d	(6) 10d x 1-1/2	800	960	6020	5785	6020	HD27925	(18) 16d	(6) 10d x 1-1/2	770	920	2450	
	HLBH27925	(15) NA16D-RS	(6) 10d x 1-1/2	935	1125	10225	10225	9600	THDH27925 ⁵	(46) 16d	(12) 16d	3490	3490	7910	
9-1/2	PHXU2795	(8) 16d	(6) 10d x 1-1/2	800	960	6020	5785	6020	HD27925	(18) 16d	(6) 10d x 1-1/2	770	920	2450	
	HLBH2795	(15) NA16D-RS	(6) 10d x 1-1/2	935	1125	10225	10225	9600	THDH27925 ⁵	(46) 16d	(12) 16d	3490	3490	7910	
11-1/4	PHXU27112	(8) 16d	(6) 10d x 1-1/2	800	960	6020	5785	6020	HD27112	(22) 16d	(6) 10d x 1-1/2	770	920	2990	
	HLBH27112	(15) NA16D-RS	(6) 10d x 1-1/2	935	1125	10225	10225	9600	THDH2710 ⁵	(56) 16d	(14) 16d	4830	5795	8705	
11-7/8	PHXU27118	(8) 16d	(6) 10d x 1-1/2	800	960	6020	5785	6020	HD27112	(22) 16d	(6) 10d x 1-1/2	770	920	2990	
	HLBH27118	(15) NA16D-RS	(6) 10d x 1-1/2	935	1125	10225	10225	9600	THDH2710 ⁵	(56) 16d	(14) 16d	4830	5795	8705	
14	PHXU2714	(8) 16d	(6) 10d x 1-1/2	800	960	6020	5785	6020	HD2714	(26) 16d	(8) 10d x 1-1/2	1025	1065	3535	
	HBLH2714	(15) NA16D-RS	(6) 10d x 1-1/2	935	1125	10225	10225	9600	THDH2714 ⁵	(66) 16d	(16) 16d	5520	6625	8985	
16	PHXU2716	(8) 16d	(6) 10d x 1-1/2	800	960	6020	5785	6020	HD2714	(26) 16d	(8) 10d x 1-1/2	1025	1065	3535	
	HLBH2716	(15) NA16D-RS	(6) 10d x 1-1/2	935	1125	10225	10225	9600	THDH2714 ⁵	(66) 16d	(16) 16d	5520	6625	8985	
2 Ply 1-3/4" or 3-1/2" Microllam® LVL or Parallam® PSL or Timberstrand® LSL															
7-1/4	-- --	-- --	-- --	-- --	-- --	-- --	-- --	-- --	THD48	(28) 16d	(16) 10d	2390	2485	3750	
9-1/4	PHXU35925	(8) 16d	(6) 10d	1020	1220	6420	5785	6420	THD410	(38) 16d	(20) 10d	2985	3585	5090	
	HLBH35925	(15) NA16D-RS	(6) 16d	1280	1420	10620	10565	9600	THDH410 ⁵	(46) 16d	(12) 16d	3970	3970	7910	
9-1/2	PHXU3595	(8) 16d	(6) 10d	1020	1220	6420	5785	6420	THD410	(38) 16d	(20) 10d	2985	3585	5090	
	HLBH3595	(15) NA16D-RS	(6) 16d	1280	1420	10620	10565	9600	THDH410 ⁵	(46) 16d	(12) 16d	3970	3970	7910	
11-1/4	PHXU35112	(8) 16d	(6) 10d	1020	1220	6420	5785	6420	THD410	(38) 16d	(20) 10d	2985	3585	5090	
	HLBH35112	(15) NA16D-RS	(6) 16d	1280	1420	10620	10565	9600	THDH412 ⁵	(56) 16d	(14) 16d	4830	5225	9560	
11-7/8	PHXU35118	(8) 16d	(6) 10d	1020	1220	6420	5785	6420	THD410	(38) 16d	(20) 10d	2985	3585	5090	
	HLBH35118	(15) NA16D-RS	(6) 16d	1280	1420	10620	10565	9600	THDH412 ⁵	(56) 16d	(14) 16d	4830	5225	9560	
14	PHXU3514	(8) 16d	(6) 10d	1020	1220	6420	5785	6420	THD410	(38) 16d	(20) 10d	2985	3585	5090	
	HLBH3514	(15) NA16D-RS	(6) 16d	1280	1420	10620	10565	9600	THDH414 ⁵	(66) 16d	(16) 16d	5520	6115	9845	
16	PHXU3516	(8) 16d	(6) 10d	1020	1220	6420	5785	6420	THD412	(48) 16d	(20) 10d	2985	3585	6430	
	HLBH3516	(15) NA16D-RS	(6) 16d	1280	1420	10620	10565	9600	THDH414 ⁵	(66) 16d	(16) 16d	5520	6115	9845	
18	PHXU3518	(8) 16d	(6) 10d	1020	1220	6420	5785	6420	THD412	(48) 16d	(20) 10d	2985	3585	6430	
	HLBH3518	(15) NA16D-RS	(6) 16d	1280	1420	10620	10565	9600	THDH414 ⁵	(66) 16d	(16) 16d	5520	6115	9845	

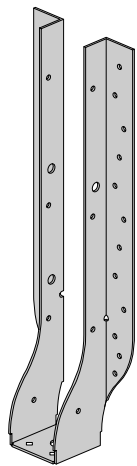

HD

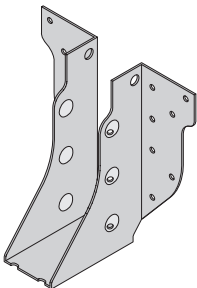

HUS

- 1) Loads listed are based on hanger attachment to a DF-L or SP species solid sawn or Microllam® LVL, Parallam® PSL, or Timberstrand® LSL header. Contact your local Trus Joist or USP Structural Connectors Technical Representative for additional duration of load values.
- 2) Uplift loads have been increased 33% or 60% for wind and seismic loading; no further increase shall be permitted.
- 3) Top Mount Hangers require a minimum 3" header width for THO series hangers; 3-1/2" minimum header thickness for all other stock numbers.
- 4) 10d x 1-1/2" nails are 9 gauge (0.148" diameter) by 1-1/2" long.
 10d and 16d nails are common wire and require a minimum penetration of 1-3/4" and 1-15/16" respectively.
 16d sinkers (0.148" diameter) by 3-1/4" long may be substituted for 10d common nails with no load reduction.
- 5) Joist nails need to be toe nailed at a 30° to 45° angle to achieve listed loads for THDH and HUS models.
- 6) For additional sizes, stock numbers, and modifications not shown, refer to USP's Full Line Catalog.

MICROLLAM® LVL, PARALLAM® PSL OR TIMBERSTRAND® LSL BEAMS & HEADERS

Microllam® LVL, Parallam® PSL or Timberstrand® LSL Beams & Headers

Joist Height	USP Stock No. 6	Top Mount Hangers ³							Face Mount Hangers						
		Fastener Schedule ⁴		Uplift ²		Down 100% ¹			USP Stock No. 6	Fastener Schedule ⁴		Uplift ²		Down 100% ¹	
		Header	Joist	133%	160%	Header Material				Header	Joist	133%	160%	Header Material	
						LVL	PSL	LSL	DF-L/SP						
3 Ply 1-3/4" or 5-1/4" Microllam® LVL or Parallam® PSL or Timberstrand® LSL															
7-1/4	--	--	--	--	--	--	--	--	--	--	--	--	--	--	
9-1/4	PHXU55925	(8) 16d	(6) 10d	1020	1220	6650	5785	6650	THD610	(38) 16d	(20) 10d	3200	3410	5360	
	HLBH55925	(15) NA16D-RS	(6) 16d	1280	1535	10620	10565	9600	THDH610 ⁵	(46) 16d	(12) 16d	4105	4930	7840	
9-1/2	PHXU5595	(8) 16d	(6) 10d	1020	1220	6650	5785	6650	THD610	(38) 16d	(20) 10d	3200	3410	5360	
	HLBH5595	(15) NA16D-RS	(6) 16d	1280	1535	10620	10565	9600	THDH610 ⁵	(46) 16d	(12) 16d	4105	4930	7840	
11-1/4	PHXU55112	(8) 16d	(6) 10d	1020	1220	6650	5785	6650	THD610	(38) 16d	(20) 10d	3200	3410	5360	
	HLBH55112	(15) NA16D-RS	(6) 16d	1280	1535	10620	10565	9600	THDH612 ⁵	(56) 16d	(14) 16d	4790	5750	9475	
11-7/8	PHXU55118	(8) 16d	(6) 10d	1020	1220	6650	5785	6650	THD610	(38) 16d	(20) 10d	3200	3410	5360	
	HLBH55118	(15) NA16D-RS	(6) 16d	1280	1535	10620	10565	9600	THDH612 ⁵	(56) 16d	(14) 16d	4790	5750	9475	
14	PHXU5514	(8) 16d	(6) 10d	1020	1220	6650	5785	6650	THD610	(38) 16d	(20) 10d	3200	3410	5360	
	HLBH5514	(15) NA16D-RS	(6) 16d	1280	1535	10620	10565	9600	THDH614 ⁵	(66) 16d	(16) 16d	5475	6570	11105	
16	PHXU5516	(8) 16d	(6) 10d	1020	1220	6650	5785	6650	THD612	(48) 16d	(20) 10d	3200	3840	6770	
	HLBH5516	(15) NA16D-RS	(6) 16d	1280	1535	10620	10565	9600	THDH614 ⁵	(66) 16d	(16) 16d	5475	6570	11105	
18	PHXU5518	(8) 16d	(6) 10d	1020	1220	6650	5785	6650	THD612	(48) 16d	(20) 10d	3200	3840	6770	
	HLBH5518	(15) NA16D-RS	(6) 16d	1280	1535	10620	10565	9600	THDH614 ⁵	(66) 16d	(16) 16d	5475	6570	11105	
4 Ply 1-3/4" or 7" Microllam® LVL or Parallam® PSL or Timberstrand® LSL															
9-1/4	PHXU71925	(8) 16d	(6) 10d	1020	1220	6650	5785	6650	THD7210	(38) 16d	(18) 16d	3360	4030	5320	
	HLBH71925	(15) NA16D-RS	(6) 16d	1280	1535	10620	10370	9600	THDH7210 ⁵	(46) 16d	(12) 16d	4105	4930	7840	
9-1/2	PHXU7195	(8) 16d	(6) 10d	1020	1220	6650	5785	6650	THD7210	(38) 16d	(18) 16d	3360	4030	5320	
	HLBH7195	(15) NA16D-RS	(6) 16d	1280	1535	10620	10370	9600	THDH7210 ⁵	(46) 16d	(12) 16d	4105	4930	7840	
11-1/4	PHXU71112	(8) 16d	(6) 10d	1020	1220	6650	5785	6650	THD7210	(38) 16d	(18) 16d	3360	4030	5320	
	HLBH71112	(15) NA16D-RS	(6) 16d	1280	1535	10620	10370	9600	THDH7212 ⁵	(56) 16d	(14) 16d	4790	5750	9475	
11-7/8	PHXU71118	(8) 16d	(6) 10d	1020	1220	6650	5785	6650	THD7210	(38) 16d	(18) 16d	3360	4030	5320	
	HLBH71118	(15) NA16D-RS	(6) 16d	1280	1535	10620	10370	9600	THDH7212 ⁵	(56) 16d	(14) 16d	4790	5750	9475	
14	PHXU7114	(8) 16d	(6) 10d	1020	1220	6650	5785	6650	THD7210	(38) 16d	(18) 16d	3360	4030	5320	
	HLBH7114	(15) NA16D-RS	(6) 16d	1280	1535	10620	10370	9600	THDH7214 ⁵	(66) 16d	(16) 16d	5475	6570	11105	
16	PHXU7116	(8) 16d	(6) 10d	1020	1220	6650	5785	6650	HD7120	(16) 16d	(6) 10d	910	1000	2175	
	HLBH7116	(15) NA16D-RS	(6) 16d	1280	1535	10620	10370	9600	THDH7214 ⁵	(66) 16d	(16) 16d	5475	6570	11105	
18	PHXU7118	(8) 16d	(6) 10d	1020	1220	6650	5785	6650	HD7140	(20) 16d	(8) 10d	1215	1460	2720	
	HLBH7118	(15) NA16D-RS	(6) 16d	1280	1535	10620	10370	9600	THDH7214 ⁵	(66) 16d	(16) 16d	5475	6570	11105	

See footnotes on page 8.

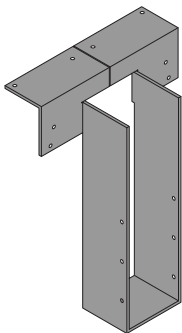

PHXU

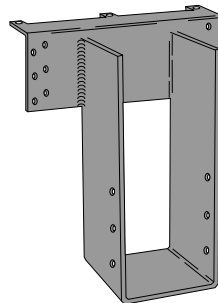

HLBH

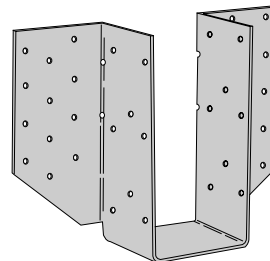

THD

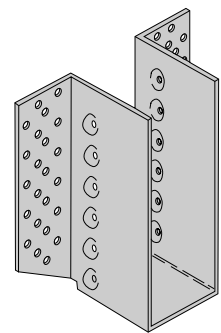

THDH

Variable Pitch Connectors – TMP & TMPH series

The *TMP* and *TMPH* is designed to make rafter-to-plate connections and eliminates time-consuming bird's-mouth notching or bevel plate installation. The *TMP* automatically adjusts to pitches from 1/12 to 6/12 and the *TMPH* from 6/12 to 14/12.

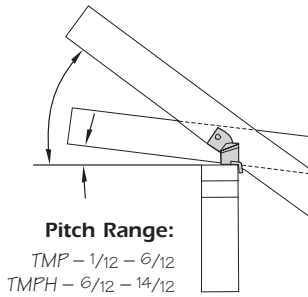

Installation:

- Use all specified fasteners.
- Position connector on top plate. Fasten connector to outside of top plate with specified nails. Insert rafter into rafter pocket. Adjust rafter and pocket to correct pitch. Fasten rafter to connector with specified nails. Installing the *TMP* requires driving specified nails through the opposing slots in the pocket. *TMPH* installation involves sliding the fulcrum until it supports the pocket at the desired pitch and nailing down through the fulcrum base into the top plate to lock the fulcrum into position.

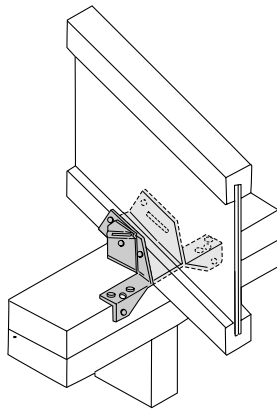

Typical **TMP** installation

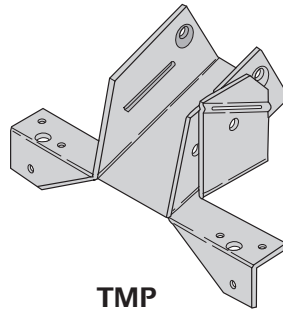

TMP

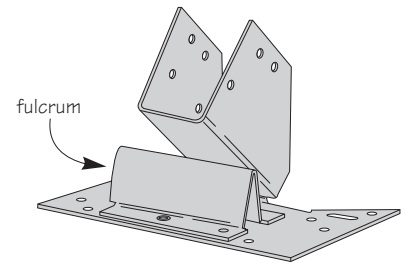

TMPH

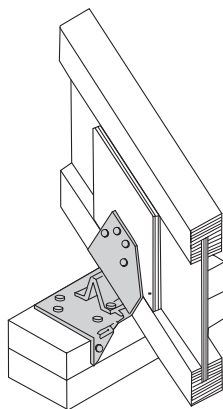

Typical **TMPH** installation

USP Stock No. ^{1,5}	Fastener Schedule ⁴		DF-L/SP		
	Header	Joist	Down ²	Uplift ³	
			100%	133%	160%
TJI® 110 Joist Width = 1-3/4"					
TMP175	(6) 10d	(4) 10d x 1-1/2	1150	220	220
TMPH175	(10) 10d	(8) 10d x 1-1/2	1945	200	200
TJI® 210 Joist Width = 2-1/16"					
---	---	---	---	---	---
TJI® 230 Joist Width = 2-5/16"					
TMP23	(6) 10d	(4) 10d x 1-1/2	1785	220	220
TMPH23	(10) 10d	(8) 10d x 1-1/2	1945	200	200
TJI® 360 Joist Width = 2-5/16"					
TMP23	(6) 10d	(4) 10d x 1-1/2	1785	220	220
TMPH23	(10) 10d	(8) 10d x 1-1/2	1945	200	200
TJI® 560 Joist Width = 3-1/2"					
TMP4	(6) 10d	(4) 10d x 1-1/2	1970	220	220
TMPH4	(10) 10d	(8) 10d x 1-1/2	1945	200	200

1) Shaded hangers require web stiffeners at joist ends. Web stiffeners may be required for non-shaded hangers by Trus Joist.

2) Loads listed are based on hanger attachment to a DF-L or SP species solid sawn or LVL header.

Loads are governed by test results; no further increase shall be permitted.

3) Uplift loads have been increased 33% or 60% for wind and seismic loading; no further increase shall be permitted.

4) 10d x 1-1/2" nails are 9 gauge (0.148" diameter) by 1-1/2" long. 10d nails are common wire and require a minimum penetration of 1-3/4" respectively.

5) For additional sizes, stock numbers, and modifications not shown, refer to USP's Full Line Catalog.

WS Series Wood Screw Applications - Joining 2, 3, or 4 Ply LVL or PSL Members

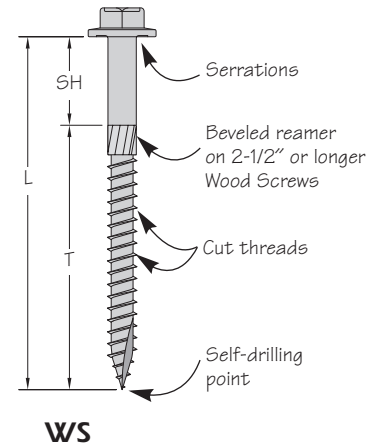
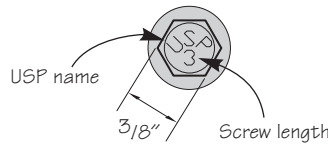

Installation:

- Screws are self-drilling.
- Install using a low speed clutch drill with 3/8" hex head driver. The washer head should be flat to the surface and the serrations will oppose turning and release the clutch. Do not over-tighten the screws.
- For 2 ply members, wood screws shall be installed with the screw heads in the loaded ply.
- For 3 or 4 ply members, wood screws shall be installed in both outer plies.
- Designer shall specify all wood screws locations.
- Increase edge and end distances if wood splitting occurs.
- Stagger all screws installed into the opposite face.

Recommended Row Guidelines -

A minimum of 2 rows of screws shall be used for all members 5 1/2" and larger

Other stagger patterns as approved by Engineer are acceptable

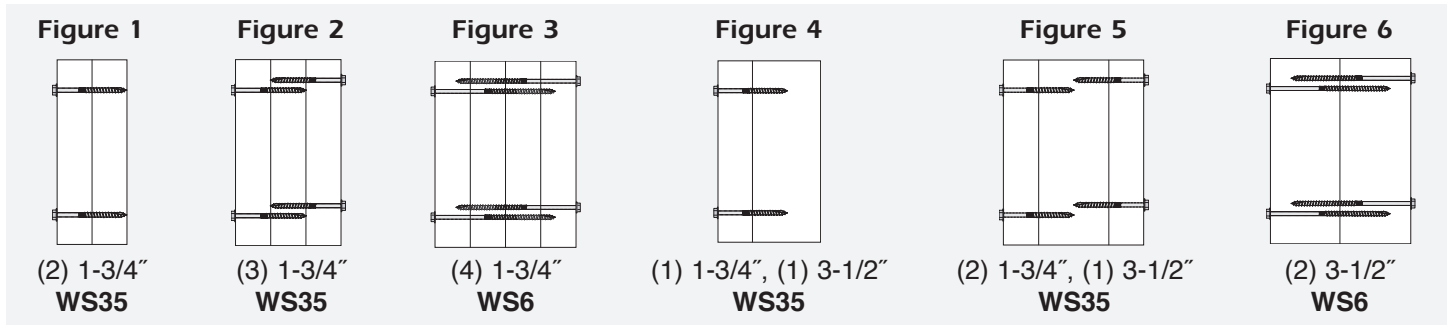
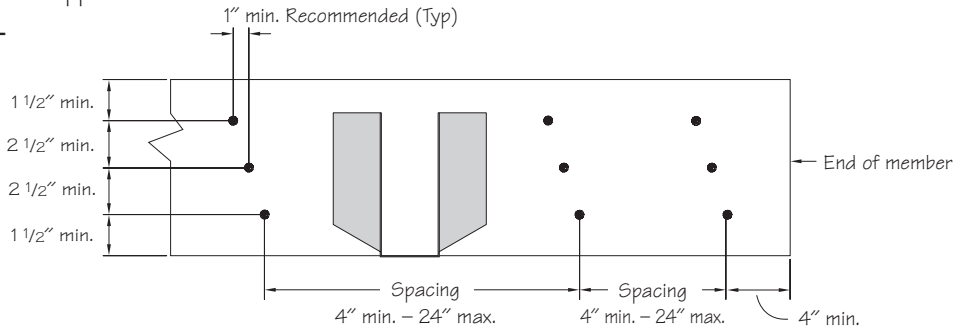

USP Stock No.	Description	Dimensions			Multiple Members Installation Figure ^{1,2,3,7}	Maximum Allowable Uniform Loads that can be applied to either outside member (Lbs. Per Lineal Ft.) ^{4,5,8}					
		L	SH	T		Douglas Fir-Larch (G = 0.50)					
						Wood Screw Spacing					
						12" O.C.		18" O.C.		24" O.C.	
2 Rows		3 Rows		2 Rows		3 Rows		2 Rows		3 Rows	
WS35	1/4" x 3-1/2"	3-1/2"	1"	2-1/2"	1	995	1495	665	995	500	745
					2	745	1120	500	745	375	560
					4	745	1120	500	745	375	560
					5	665	995	440	665	330	500
WS6 ⁶	1/4" x 6"	6"	1-3/4"	4-1/4"	3	665	995	440	665	330	500
					6	995	1495	665	995	500	745

1) Based on Zscrew = 249 pounds in Douglas Fir-Larch with a side member thickness of not less than 1-3/4".
 2) Load values depicted assume all uniform load is applied to the most narrow outside ply only.
 3) Load values neglect any contribution of screws installed to opposite side, even if they extend significantly into the loaded ply.
 4) Loads are for normal (100%) duration of load, and may be increased in accordance with the code.
 5) Uniform loads in table represent the capacity of the fasteners. The capacity of the Microllam® LVL, Parallam® PSL, or TimberStrand® LSL beam may be less and should be checked by a qualified designer or with the manufacturer's literature.
 6) Wood screws longer than 3-1/2" are not recommended for use with TimberStrand® LSL.
 7) For Figures 2, 3, 5, and 6: Stagger the screws on opposite face by half minimum spacing requirements.
 8) A qualified designer shall ensure the adequacy of a 7" wide beam to resist the applied load on one edge; otherwise, the loads shall be uniformly distributed across the width or applied equally on both sides.

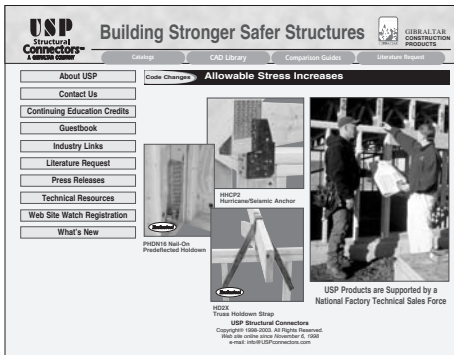

Comprehensive Web Site

- Contains all USP literature in a printable .pdf format
- **CAD Menu Program** and **Drawing Library** downloads
- **Quick** and **Easy** literature ordering
- Register on-line at **Web Site Watch Registration** and automatically receive product updates through your e-mail

CAD Menu Program

- Install a new **USP Drop Down Menu** in your AutoCAD menu bar (AutoCAD r14, AutoCAD 2000, 2000i, 2002, 2004)
 - Import scalable USP product drawings directly into your details or section drawings
- Available in 3-view format; top, front, and side where applicable

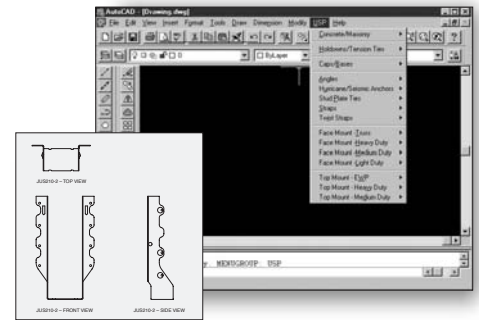

CAD Library

- CAD Library contains over 350 illustrations in .DXF and .DWG formats
- Find drawings quickly by USP Stock No. or Reference No.
- High Wind Illustrations are also available

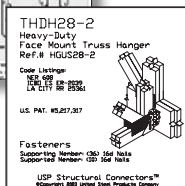
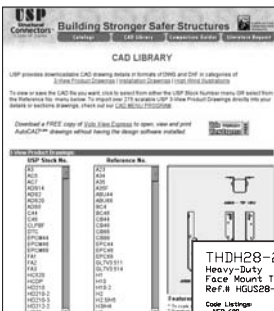

Comparison Guides

- Compare USP code & load values side-by-side with our competitor
- Each Table shows **Connector rated values Code Evaluation listings**
 - Indexed by USP Stock No. and Reference No.

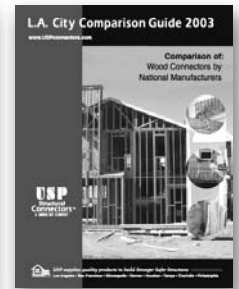
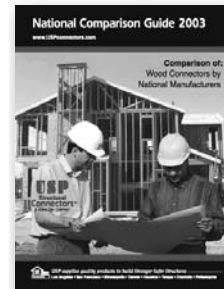

LUS						JUS					
NER-209, NER-421, NER-499, ICBO ES ER-5640, ICBO ES ER-5656, ICBO ES ER-5683						NER-608 pg. 10 & 11, ICBO ES ER-5356 pg. 3, ICBO ES ER-2038 pg. 24					
Simpson Stock No.	Design Load					USP Stock No.	Design Load				
	Floor	Roof	Roof	Uplift	Uplift		Floor	Roof	Roof	Uplift	Uplift
	100%	115%	125%	133%	160%		100%	115%	125%	133%	160%
LUS24	640	735	800	865	460	JUS24	645	740	805	870	510
LUS26	830	955	1040	930	1115	JUS26	840	970	1050	1115	1115
LUS28	1055	1210	1320	830	1115	JUS28	1055	1225	1330	1115	1115
LUS210	1275	1470	1595	930	1115	JUS210	1280	1485	1610	1115	1115
LUS24-2	785	880	960	440	440	JUS24-2	770	885	985	325	325
LUS26-2	1000	1130	1230	1140	1165	JUS26-2	1005	1160	1200	1340	1320
LUS28-2	1265	1455	1585	1140	1165	JUS28-2	1275	1465	1595	1340	1350
LUS210-2	1765	2030	2210	1710	1745	JUS210-2	1780	2045	2225	1980	1980
LUS214-2	2030	2335	2540	1710	1745	JUS214-2	2315	2660	2895	1980	1980



Your Local Dealer / Distributor

Livermore, CA Office
2150 Kitty Hawk Road
Livermore, CA 94551-9522
1-800-227-0470 • Fax: 1-925-373-9213

Montgomery, MN Corporate Office
703 Rogers Drive
Montgomery, MN 56069-1324
1-800-328-5934 • Fax: 1-507-364-8762

Largo, FL Office
11910 62nd Street North
Largo, FL 33773-3705
1-800-443-6442 • Fax: 1-727-535-8199