

EWP Product Guide

www.USPconnectors.com

For Use With Products Manufactured by

BOISESM

Building Solutions
Engineered Wood Products

ALLJoist[®]



THF17925



LSSH25



THO25118

USP

Structural
Connectors™

A GIBRALTAR INDUSTRIES COMPANY 

U.S./Working Stress



USP supplies quality products to build Stronger Safer Structures—————
Rancho Cucamonga • Livermore • Montgomery • Houston • Largo • North Wilkesboro • Lumberton

General Notes

- See current USP Full Line Catalog for General Notes, Warranty, and installation information for hanger models, joist sizes, and header situations not shown.
- Loads listed address hanger/header/fastener limitations assuming header material is Douglas Fir-Larch, Southern Pine, or LVL manufactured in the U.S. Joist reaction should be checked by a qualified designer to ensure proper hanger selection.
- Uplift loads have been increased 33% for U.S./Working Stress for wind or seismic loads and no further increase shall be permitted. Reduce loads according to code for normal duration loading such as cantilever construction.
- If hanger height is less than 60% of joist height, joist rotation may occur; see page 3.
- The type and quantity of fasteners used to install USP products is critical to connector performance. To achieve the allowable loads shown in this catalog, install with the fasteners specified for that particular product. All specified fasteners must be properly installed prior to applying load

Follow these instructions to ensure the proper installation of USP products.

- of any kind to the connection.
- Throughout this catalog, dimensions are expressed in inches and loads in pounds, unless specifically noted otherwise.
- Load values for 10d and 16d designations in the fastener schedules throughout this catalog refer to common wire nails, unless note otherwise.
- The allowable loads shown in this catalog are based on Allowable Stress Design and Limit States Design methodologies.
- *Multiple I-Joist Plies:* Fasten together multiple plies of wood I-Joists, in accordance with the manufacturer's installation guidelines, such that the joists act as a single unit.
- *Sloped I-Joists:* Use sloped seat hangers and beveled web stiffeners whenever the slope exceeds the following: 1/2:12 for seat bearing lengths of 2 1/2" or less; 3/8:12 for bearing lengths between 2 1/2" and 3 1/2"; and 1/4:12 for bearing lengths in excess of 3 1/2".

Backer Blocks – Pattern the nails used to install backer blocks or web stiffeners in wood I-Joists to avoid splitting the block. The nail pattern should be sufficiently spaced to avoid the same grain line, particularly with solid sawn backer blocks. Backer blocks must be installed on wood

I-Joist acting as the header, or supporting member. Install in accordance with the I-Joist manufacturer's installation guidelines. The nails used to install hangers mounted to an I-Joist header must penetrate through the web and into the backer block on the opposite side.

With top flange hangers, backer block required only for downward loads exceeding 250 lbs for uplift conditions

Filler and Backer Block sizes

Joist Series	Joist Depth	Backer Block Thickness	Filler Block Thickness
AJS™ 20 AJS™ 140	9-1/2"	1-1/8"	2 x 6 + 5/8" panel
	11-7/8"	1-1/8"	2 x 8 + 5/8" panel
	14"	1-1/8"	2 x 10 + 5/8" panel
AJS™ 25	16"	1-1/2"	2 x 12 + 5/8" panel
	9-1/2"	1-1/2"	2 -2 x 6
	11-7/8"	1-1/2"	2 -2 x 8
	14"	1-1/2"	2 -2 x 10
	16"	1-1/2"	2 -2 x 12

- Notes:
1. Leave a 1/4" gap between top of filler block and bottom of top i-joist flange.
 2. The minimum grade of lumber for filler block material is S-P-F STUD.
 3. Any structural panel or rim board product is permitted.

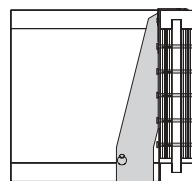

Typical THO backer block installation

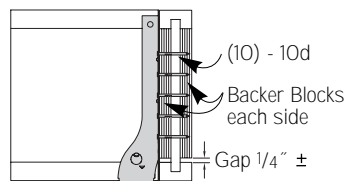

Typical THF backer block installation

Backer Block Installation:
Install tight to top flange (tight to bottom flange with face mount hangers). Attach with ten 10d (3") box nails, clinched when possible

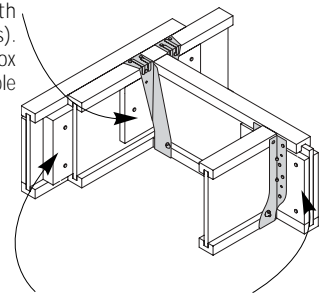

Filler Block Installation:
Nail with ten 10d (3") box nails, clinched. Use ten (3 1/2") box nails from each side with AJS™ Joists

Backer Block (both sides) of web with single AJS™ Joist

Web Stiffener Attachment

Web Stiffeners are optional except as noted below:

- Web stiffeners are always required in hangers that do not extend up to support the top flange of the AJS™ Joist. Web stiffeners may be required with certain sloped or skewed hangers or to achieve uplift values. Refer to the hanger manufacturer's installation requirements.

Web Stiffener Nailing Schedule		
Joist Series	Joist Depth	Bearing Location
		End
AJS™ 140 or AJS™ 20	9-1/2"	(3) 10d
	11-7/8"	(3) 10d
	14"	(5) 10d
AJS™ 25	16"	(5) 10d
	9-1/2"	(3) 10d
	11-7/8"	(3) 10d
	14"	(5) 10d
	16"	(5) 10d

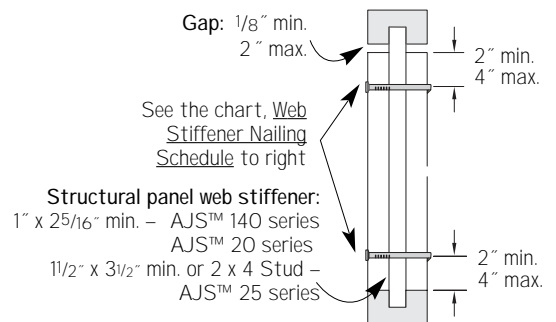

Support Height & Lateral Stability

Hangers for joists **without web stiffeners** must support the I-Joist's top flange and provide lateral resistance with no more than 1/8" horizontal deflection.

Hangers for joists **with web stiffeners** must support a minimum of 60% of joist depth.

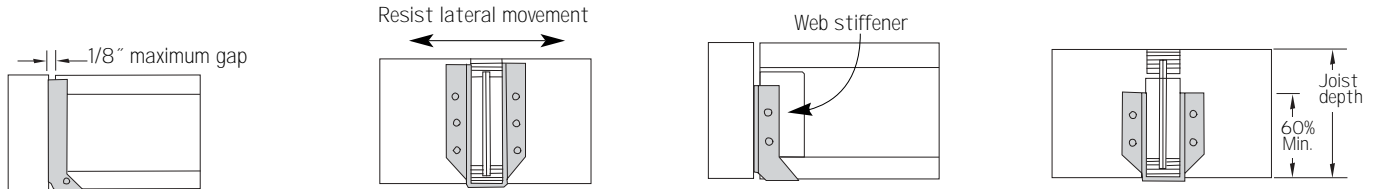

(Top flange support requirements can be verified in *EWP Top Mount Hangers* charts under the *Web Stiffener Req.* column of USP's *Full Line Catalog*.)

Nailer Installations

Correct Hanger Attachment to Nailer

A nailer or sill plate is considered to be any wood member attached to a steel beam, concrete block wall, concrete stem wall, or other structure unsuitable for nailing, which is used as a nailing surface for top mount hangers to hold beams or joists.

Nailer Sized Correctly

Top flange of hanger is fully supported and recommended nails have full penetration into nailer, resulting in a carried member hanging safely at the proper height.

The nailer must be sized to fit the support width as shown and be of sufficient thickness to satisfy recommended top flange nailing requirements. A design professional must specify nailer attachment to steel beams.

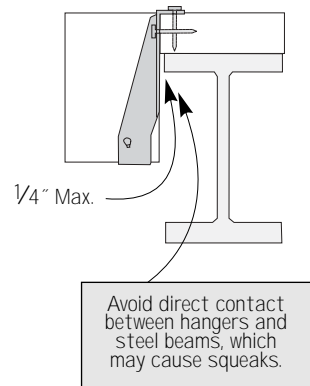

Wrong Nailer Size Causes Component Failure

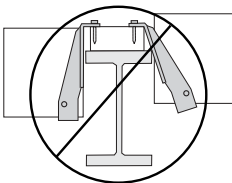

Too Narrow

Top flange not fully supported can cause nail breakout. Or, by fully supporting top flange, hanger is tilted back, causing lifting of carried member which results in uneven surfaces and squeaky floors.

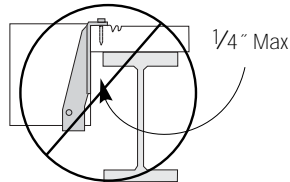

Too Wide

Loading can cause cross grain breaking of nailer. The recommended nailer overhang is 1/4" maximum per side.

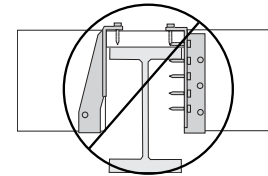

Too Thin

Top flange nailing cannot fully penetrate nailer, causing reduced allowable loads. Never use hangers which require multiple face nails since the allowable loads are dependent on all nail holes being used.

Top Flange Hangers

The thickness of the hanger metal and nail heads on top mount hangers must be evaluated for the effect on subsequent sheathing. Ensure the top mount hanger is installed so the flanges of the hanger are not *over-spread* which tends to elevate the supported I-Joist, causing uneven floor surfaces and squeaking. Similarly, ensure the hanger is installed plumb such that the face flanges of the hanger are mounted firmly against the wide-face surface of the header.

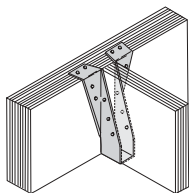

Flush framing

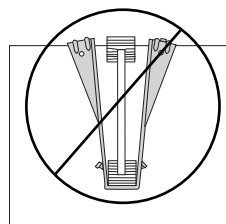

Hanger over-spread

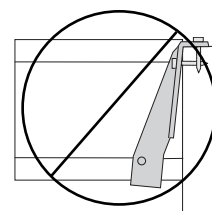

Hanger not plumb

U.S./Working Stress (Lb.) – Single AJS™ Joists

Joist Height	Top Mount Hangers ⁴								Face Mount Hangers																		
	USP Stock No. ^{1,6}	Fastener Schedule ⁵		DF-L/SP		S-P-F		USP Stock No. ^{1,6}	Fastener Schedule ⁵		DF-L/SP		S-P-F														
		Header	Joist	Down ² 100%	Uplift ³ 133%	Down ² 100%	Uplift ³ 133%		Header	Joist	Down ² 100%	Uplift ³ 133%	Down ² 100%	Uplift ³ 133%													
AJS™ 140 or AJS™ 20														Joist Width = 2-1/2"													
9-1/2	TFL2595	(6) 10d	(2) 10d x 1-1/2	1600	300	1230	260	THF25925	(12) 10d	(2) 10d x 1-1/2	1370	175	1175	175													
11-7/8	TFL25118	(6) 10d	(2) 10d x 1-1/2	1600	300	1230	260	THF25112	(14) 10d	(2) 10d x 1-1/2	1595	300	1370	260													
14	TFL25140	(6) 10d	(2) 10d x 1-1/2	1600	300	1230	260	THF25140	(18) 10d	(2) 10d x 1-1/2	2090	300	1800	260													
16	TFL25160	(6) 10d	(2) 10d x 1-1/2	1600	300	1230	260	THF25160	(22) 10d	(2) 10d x 1-1/2	2550	300	2200	260													
AJS™ 25														Joist Width = 3-1/2"													
9-1/2	THO35950	(10) 10d	(2) 10d x 1-1/2	2050	300	2050	260	THF35925	(12) 10d	(2) 10d x 1-1/2	1370	245	1175	245													
11-7/8	THO35118	(10) 10d	(2) 10d x 1-1/2	2050	300	2050	260	THF35112	(16) 10d	(2) 10d x 1-1/2	1825	245	1570	245													
14	THO35140	(12) 10d	(2) 10d x 1-1/2	2715	265	2100	260	THF35140	(20) 10d	(2) 10d x 1-1/2	2320	245	2000	245													
16	THO35160	(12) 10d	(2) 10d x 1-1/2	2715	265	2100	260	THF35157	(22) 10d	(2) 10d x 1-1/2	2550	245	2200	245													

- Web stiffeners may be required for hangers by I-joist manufacturers.
- Loads listed are based on 2001 NDS® and hanger attachment to a DF-L, SP, or S-P-F species solid sawn or LVL header. Some loads may be increased for duration of load adjustments. Refer to USP Full Line Catalog for details.
- Uplift loads have been increased 33% for wind and seismic loading; no further increase shall be permitted.
- Top Mount Hangers require minimum 3" header width for THO series hangers; 3-1/2" minimum header thickness for all other stock numbers.
- 10d x 1-1/2" nails are 9 gauge (0.148" diameter) by 1-1/2" long. Minimum nail penetration shall be 1-1/2" for 10d nails. 16d sinkers (0.148" diameter) by 3-1/4" long may be substituted for 10d common nails with no load reduction.
- For additional sizes, stock numbers, and modifications not shown, refer to USP's Full Line Catalog.

Joist Height	Adjustable Height Hangers								Skewed 45° Hangers																		
	USP Stock No. ^{1,5}	Fastener Schedule ⁴		DF-L/SP		S-P-F		USP Stock No. ^{1,5}	Fastener Schedule ⁴		DF-L/SP		S-P-F														
		Header	Joist	Down ² 100%	Uplift ³ 133%	Down ² 100%	Uplift ³ 133%		Plate	Rafter	Down ² 100%	Uplift ³ 133%	Down ² 100%	Uplift ³ 133%													
AJS™ 140 or AJS™ 20														Joist Width = 2-1/2"													
9-1/2	--	--	--	--	--	--	--	SKH2520L/R	(14) 10d	(10) 10d x 1-1/2	1625	1505	1400	1295													
11-7/8	MSH318	(6) 10d	(4) 10d x 1-1/2	2165	--	2055	--	SKH2520L/R	(14) 10d	(10) 10d x 1-1/2	1625	1505	1400	1295													
14	MSH318	(6) 10d	(4) 10d x 1-1/2	2165	--	2055	--	SKH2524L/R	(16) 10d	(10) 10d x 1-1/2	1855	1505	1600	1295													
16	MSH318	(6) 10d	(4) 10d x 1-1/2	2165	--	2055	--	SKH2524L/R	(16) 10d	(10) 10d x 1-1/2	1855	1505	1600	1295													
AJS™ 25														Joist Width = 3-1/2"													
10	MSH422	(6) 10d	(6) 10d	2025	--	2025	--	SKH410L/R ⁶	(16) 16d	(10) 16d	2240	1565	1935	1565													
11-7/8	MSH422	(6) 10d	(6) 10d	2025	--	2025	--	SKH410L/R ⁶	(16) 16d	(10) 16d	2240	1565	1935	1565													
14	--	--	--	--	--	--	--	SKH414L/R ⁶	(22) 16d	(10) 16d	3080	1565	2660	1565													
16	--	--	--	--	--	--	--	SKH414L/R ⁶	(22) 16d	(10) 16d	3080	1565	2660	1565													

- Shaded hangers require web stiffeners at joist ends. Web stiffeners may be required for non-shaded hangers by I-joist manufacturers.
- Loads listed are based on 2001 NDS® and hanger attachment to a DF-L, SP, or S-P-F species solid sawn or LVL header. Some loads may be increased for duration of load adjustments. Refer to USP Full Line Catalog for details.
- Uplift loads have been increased 33% for wind and seismic loading; no further increase shall be permitted.
- 10d x 1-1/2" nails are 9 gauge (0.148" diameter) by 1-1/2" long. Minimum nail penetration shall be 1-1/2" for 10d nails and 1-5/8" for 16d nails.
- For additional sizes, stock numbers, and modifications not shown, refer to USP's Full Line Catalog.
- Miter cut required on end of joist to achieve design loads.

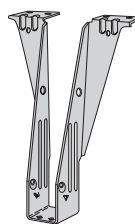

THO

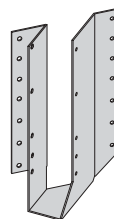

SKH_L
left shown

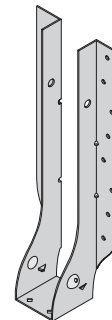

THF single

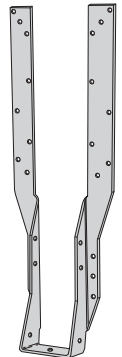

MSH

U.S./Working Stress (Lb.) – Double AJS™ Joists

Joist Height	Top Mount Hangers ⁴							Face Mount Hangers							
	USP Stock No. ^{1,6}	Fastener Schedule ⁵		DF-L/SP		S-P-F		USP Stock No. ^{1,6}	Fastener Schedule ⁵		DF-L/SP		S-P-F		
		Header	Joist	Down ² 100%	Uplift ³ 133%	Down ² 100%	Uplift ³ 133%		Header	Joist	Down ² 100%	Uplift ³ 133%	Down ² 100%	Uplift ³ 133%	
AJS™ 140 or AJS™ 20														Joist Width = 5"	
9-1/2	THO25950-2	(10) 16d	(6) 10d	3535	1000	3000	870	THF25925-2	(12) 10d	(6) 10d	1390	930	1200	870	
11-7/8	THO25118-2	(10) 16d	(6) 10d	3535	1000	3000	870	THF25112-2	(16) 10d	(6) 10d	1855	930	1600	870	
14	THO25140-2	(12) 16d	(6) 10d	3535	1000	3300	870	THF25140-2	(20) 10d	(6) 10d	2500	1000	2180	870	
16	THO25160-2	(12) 16d	(6) 10d	3535	1000	3300	870	THF25160-2	(24) 10d	(6) 10d	3000	1000	2615	870	
AJS™ 25														Joist Width = 7"	
9-1/2	BPH7195	(10) 16d	(6) 10d	3510	1000	3280	870	HD7100	(12) 16d	(6) 10d	1680	945	1450	870	
11-7/8	BPH71118	(10) 16d	(6) 10d	3510	1000	3280	870	HD7120	(16) 16d	(6) 10d	2240	945	1935	870	
14	BPH7114	(10) 16d	(6) 10d	3510	1000	3280	870	HD7140	(20) 16d	(8) 10d	2800	1260	2420	870	
16	BPH7116	(10) 16d	(6) 10d	3510	1000	3280	870	HD7160	(24) 16d	(8) 10d	3360	1260	2905	870	

- 1) Shaded hangers require web stiffeners at joist ends. Web stiffeners may be required for non-shaded hangers by I-joist manufacturers.
- 2) Loads listed are based on 2001 NDS® and hanger attachment to a DF-L, SP, or S-P-F species solid sawn or LVL header.
Some loads may be increased for duration of load adjustments. Refer to USP Full Line Catalog for details.
- 3) Uplift loads have been increased 33% for wind and seismic loading; no further increase shall be permitted.
- 4) Top Mount Hangers require minimum 3" header width for THO series hangers; 3-1/2" minimum header thickness for all other stock numbers.
- 5) 10d x 1-1/2" nails are 9 gauge (0.148" diameter) by 1-1/2" long.
Minimum nail penetration shall be 1-1/2" for 10d nails and 1-5/8" for 16d nails.
16d sinkers (0.148" diameter) by 3-1/4" long may be substituted for 10d common nails with no load reduction.
- 6) For additional sizes, stock numbers, and modifications not shown, refer to USP's Full Line Catalog.

Joist Height	Adjustable Height Hangers							Skewed 45° Hangers							
	USP Stock No. ^{1,5}	Fastener Schedule ⁴		DF-L/SP		S-P-F		USP Stock No. ^{1,5}	Fastener Schedule ⁴		DF-L/SP		S-P-F		
		Header	Joist	Down ² 100%	Uplift ³ 133%	Down ² 100%	Uplift ³ 133%		Plate	Rafter	Down ² 100%	Uplift ³ 133%	Down ² 100%	Uplift ³ 133%	
AJS™ 140 or AJS™ 20														Joist Width = 5"	
9-1/2	MSH2622-2	(6) 10d	(4) 10d	2210	--	2210	--	SKH2520L/R-2 ⁷	(14) 10d	(10) 10d	1650	1575	1430	1360	
11-7/8	MSH2622-2	(6) 10d	(4) 10d	2210	--	2210	--	SKH2524L/R-2 ⁷	(16) 10d	(10) 10d	1890	1575	1630	1360	
14	MSH2622-2	(6) 10d	(4) 10d	2210	--	2210	--	SKH2524L/R-2 ⁷	(16) 10d	(10) 10d	1890	1575	1630	1360	
16	MSH2622-2	(6) 10d	(4) 10d	2210	--	2210	--	SKH2524L/R-2 ⁷	(16) 10d	(10) 10d	1890	1575	1630	1360	
AJS™ 25														Joist Width = 7"	
9-1/2	--	--	--	--	--	--	--	HD7100-SK45L/R ^{6,7}	(12) 16d	(6) 10d	1680	710	1450	655	
11-7/8	MSH422-2	(8) 16d	(6) 16d	4200	--	3210	--	HD7120-SK45L/R ^{6,7}	(16) 16d	(6) 10d	2240	710	1935	655	
14	MSH422-2	(8) 16d	(6) 16d	4200	--	3210	--	HD7140-SK45L/R ^{6,7}	(20) 16d	(8) 10d	2800	945	2420	655	
16	MSH422-2	(8) 16d	(6) 16d	4200	--	3210	--	HD7160-SK45L/R ^{6,7}	(24) 16d	(8) 10d	3360	945	2905	655	

- 1) Shaded hangers require web stiffeners at joist ends. Web stiffeners may be required for non-shaded hangers by I-joist manufacturers.
- 2) Loads listed are based on 2001 NDS® and hanger attachment to a DF-L, SP, or S-P-F species solid sawn or LVL header.
Some loads may be increased for duration of load adjustments. Refer to USP Full Line Catalog for details.
- 3) Uplift loads have been increased 33% for wind and seismic loading; no further increase shall be permitted.
- 4) 10d x 1-1/2" nails are 9 gauge (0.148" diameter) by 1-1/2" long.
Minimum nail penetration shall be 1-1/2" for 10d nails and 1-5/8" for 16d nails.
16d sinkers (0.148" diameter) by 3-1/4" long may be substituted for 10d common nails with no load reduction.
- 5) For additional sizes, stock numbers, and modifications not shown, refer to USP's Full Line Catalog.
- 6) Hangers are special order. Consult USP for pricing and lead times.
- 7) Miter cut required on end of joist to achieve design loads.

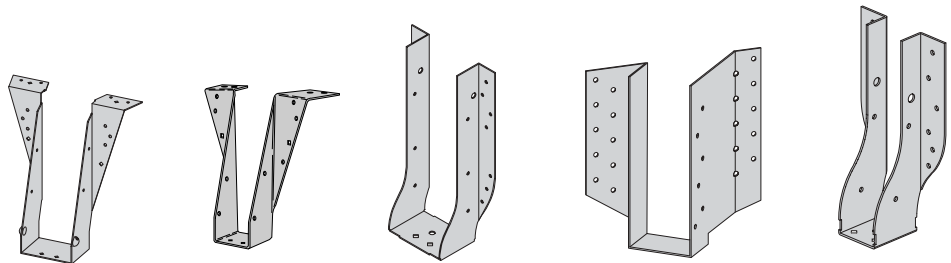

THO-Double

BPH

THF-Double

SKH_L-Double
left shown

HD-Double

U.S./Working Stress (Lb.) – Single AJS™ Joists

Joist Height	Slope and Skew Hangers						
	USP Stock No. ^{1,5}	Fastener Schedule ⁴		DF-L/SP		S-P-F	
		Header	Joist	Down ² 100%	Uplift ³ 133%	Down ² 100%	Uplift ³ 133%
AJS™ 140 or AJS™ 20 Joist Width = 2-1/2"							
9-1/2	LSSH25	(14) 16d	(12) 10d x 1-1/2	1825	1195	1665	1195
11-7/8	LSSH25	(14) 16d	(12) 10d x 1-1/2	1825	1195	1665	1195
14	LSSH25	(14) 16d	(12) 10d x 1-1/2	1825	1195	1665	1195
16	LSSH25 ⁶	(14) 16d	(12) 10d x 1-1/2	1825	1195	1665	1195
AJS™ 25 Joist Width = 3-1/2"							
9-1/2	LSSH35	(14) 16d	(12) 10d x 1-1/2	1920	1585	1665	1585
11-7/8	LSSH35	(14) 16d	(12) 10d x 1-1/2	1920	1585	1665	1585
14	LSSH35	(14) 16d	(12) 10d x 1-1/2	1920	1585	1665	1585
16	LSSH35 ⁶	(14) 16d	(12) 10d x 1-1/2	1920	1585	1665	1585

- 1) Shaded hangers require web stiffeners at joist ends. Web stiffeners may be required for non-shaded hangers by I-joist manufacturers.
- 2) Loads listed are based on 2001 NDS® and hanger attachment to a DF-L, SP, or S-P-F species solid sawn or LVL header. Some loads may be increased for duration of load adjustments. Refer to USP Full Line Catalog for details.
- 3) Uplift loads have been increased 33% for wind and seismic loading; no further increase shall be permitted.
- 4) 10d x 1-1/2" nails are 9 gauge (0.148" diameter) by 1-1/2" long.
Minimum nail penetration shall be 1-5/8" for 16d nails.
- 5) For additional sizes, stock numbers, and modifications not shown, refer to USP's Full Line Catalog.
- 6) LSTA24 strap required along top chord for lateral restraint.

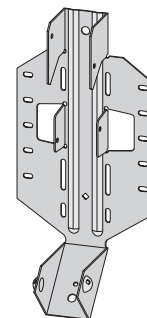

LSSH

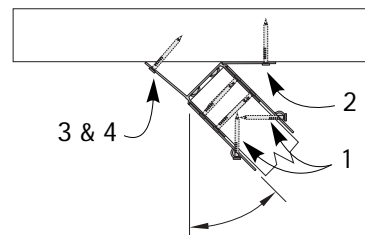

skew to 45° maximum

 **Installation:**

- Use all specified fasteners

Steps:

1. Position LSSH connector against plumb-cut end of joist. Fasten joist side flanges on both sides with 10d x 1 1/2" nails. Bend seat up to fit against joist bottom and drive (1) 10d x 1 1/2" nail through bottom seat into rafter bottom. Drive (2) 10d x 1 1/2" nails at downward angle through dimpled nailing guides.
 2. Lean connector and rafter end against ridge beam at desired position. Install 10d or 16d nails through nail holes into ridge beam at right 90° angle. If skewing the rafter, only drive nails into ridge beam on inside flange.
 3. Bend flange to desired angle.
 4. Hammer outside flange until edge touches header. Fasten outside flange to ridge by driving 10d or 16d nails through nail holes.
- Web stiffeners are required for all wood I-Joist installations.
 - Designer may consider adding a tension restraint for the supported member for roof slopes exceeding 6/12.

U.S./Working Stress (Lb.) – Single AJS™ Joists

Variable Pitch Connectors						
USP Stock No. ^{1,5}	Fastener Schedule ⁴		DF-L/SP		S-P-F	
	Header	Joist	Down ²	Uplift ³	Down ²	Uplift ³
			100%	133%	100%	133%
AJS™ 140 or AJS™ 20			Joist Width = 2-1/2"			
TMP25	(6) 10d	(4) 10d x 1-1/2	1825	220	1825	220
TMPH25	(10) 10d	(8) 10d x 1-1/2	1945	200	1945	200
AJS™ 25			Joist Width = 3-1/2"			
TMP4	(6) 10d	(4) 10d x 1-1/2	1970	220	1970	220
TMPH4	(10) 10d	(8) 10d x 1-1/2	1945	200	1945	200

- 1) Shaded hangers require web stiffeners at joist ends. Web stiffeners may be required for non-shaded hangers by I-joist manufacturers.
- 2) Loads listed are based on 2001 NDS® and hanger attachment to a DF-L, SP, or S-P-F species solid sawn or LVL header. Loads are governed by test results; no further increase shall be permitted.
- 3) Uplift loads have been increased 33% for wind and seismic loading; no further increase shall be permitted.
- 4) 10d x 1-1/2" nails are 9 gauge (0.148" diameter) by 1-1/2" long.
Minimum nail penetration shall be 1-1/2" for 10d nails.
- 5) For additional sizes, stock numbers, and modifications not shown, refer to USP's Full Line Catalog.

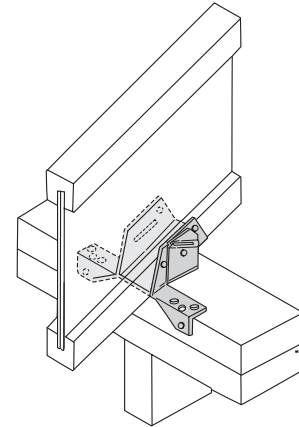

Typical TMP installation

Installation:

- Use all specified fasteners.
- Position connector on top plate. Fasten connector to outside of top plate with specified nails. Insert rafter into rafter pocket. Adjust rafter and pocket to correct pitch. Fasten rafter to connector with specified nails. Installing the **TMP** requires driving specified nails through the opposing slots in the pocket. **TMPH** installation involves sliding the fulcrum until it supports the pocket at the desired pitch and nailing into the fulcrum base into the top plate to lock the fulcrum into position.

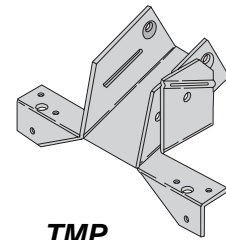

TMP

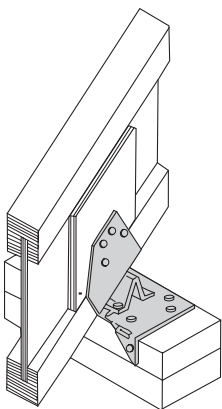

Typical TMPH installation

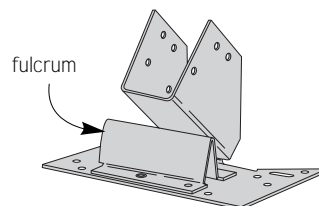

TMPH

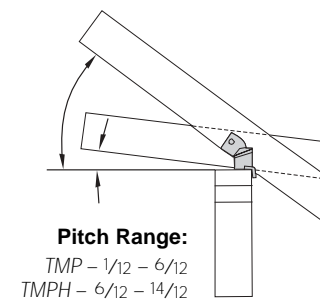

Livermore, CA Office
2150 Kitty Hawk Road
Livermore, CA 94551-9522
1-800-227-0470 • Fax: 1-925-373-9213

Montgomery, MN Corporate Office
703 Rogers Drive
Montgomery, MN 56069-1324
1-800-328-5934 • Fax: 1-507-364-8762
www.USPconnectors.com

Largo, FL Office
11910 62nd Street North
Largo, FL 33773-3705
1-800-443-6442 • Fax: 1-727-535-8199

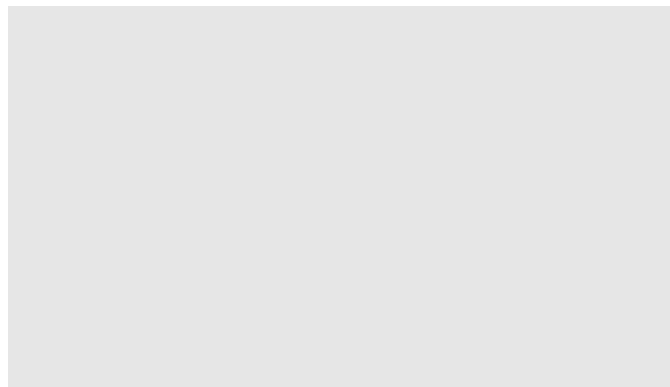
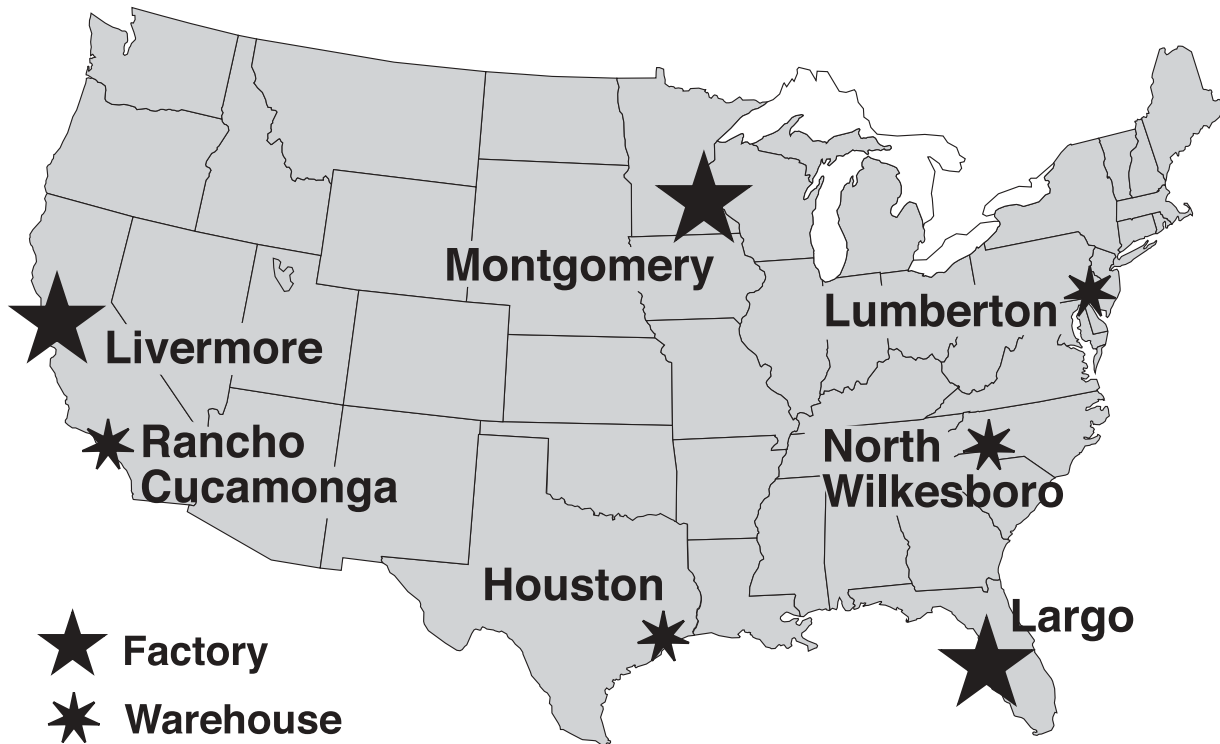

Your Local Dealer / Distributor