

RT16M

HURRICANE RETRO-FIT CONNECTOR

Materials: 18 gauge
Finish: G90 galvanizing
Codes: FL10739 (2007)

Installation:

- Use all specified fasteners.
- Tapcon® Concrete Screws are not supplied with RT16M connector.
- Install Tapcon® Concrete Screws in lower two holes for Single Top Plate or Conventional Raised Foundation or Modular Home installations.
- Moisture barrier may be required.

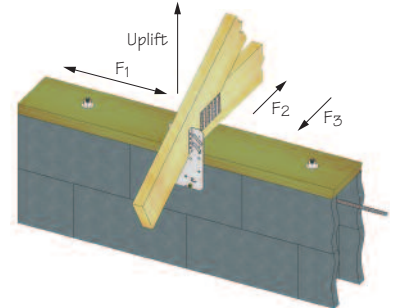

Single Top Plate Installation

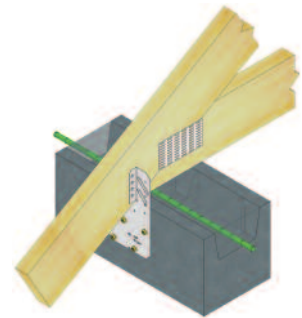

Block Wall Installation

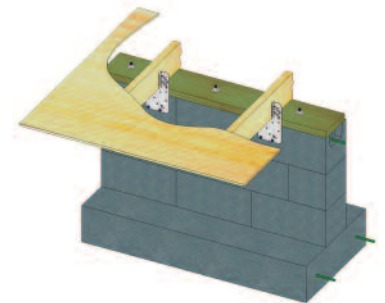

Conventional Raised Foundation or Modular Home

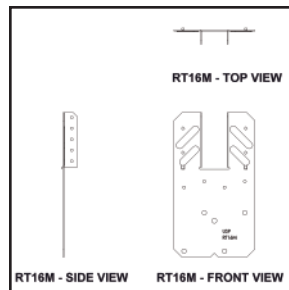
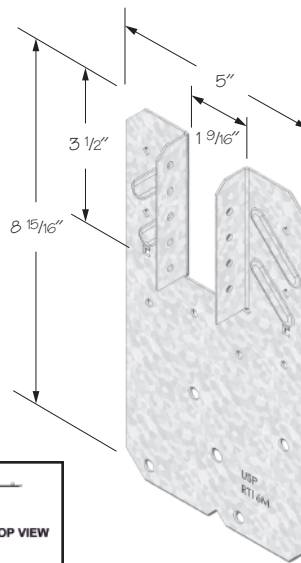

Go to www.uspconnectors.com/cad/ for Downloadable CAD drawings

New Product

Usage:

» Designed as a retrofit connector for trusses installed on top plates.

» Can also be used as a holdown for a roof or floor system.

Features:

» Installs after the truss has been placed.

» Provides high uplift and lateral loading.

» Meets requirements for the 2004 and 2007 Florida Building Code.

USP supplies quality products to build Stronger Safer Structures

Customer Service:
 Burnsville, MN
 Phone: 1-800-328-5934
 Fax: 1-507-364-8762

Manufacturing:
 Montgomery, MN
 Livermore, CA
 Largo, FL
 Thornhill, Ontario

Warehouses:
 Houston, TX
 Lumberton, NJ

www.USPconnectors.com

USP Stock No.	Ref. No.	Fastener Schedule ^{2,3,4}						Allowable Loads (Lbs.) ¹				Ctn Qty	
		Truss/Rafter		Top Plate		Masonry Block		on of	DF-L / SP		S-P-F		
		Qty	Type	Qty	Type	Qty	Type		133%	160%	133%		160%
RT16M	HM9	9	10d x 1-1/2	---	---	4	1/4" x 1-3/4" Tapcon	Uplift	1395	1395	1185	1395	25
				F1	630			630	630	630			
		9	10d x 1-1/2	4	16d	2	1/4" x 1-3/4" Tapcon	F2	480	480	480	480	
				F3	115			115	115	115			
								Uplift	1360	1360	1185	1360	

1) Allowable loads have been increased 33-1/3% or 60% for wind or seismic loads; no further increase shall be permitted.
 2) 10d x 1-1/2 nails are 9 gauge (0.148" diameter) by 1-1/2" long.
 3) Install with 1/4" x 1-3/4" Tapcon® Concrete Screws in accordance to manufacturer's installation specifications.
 4) Fasteners to be installed to fully grouted and reinforced concrete masonry.
 *Consult USP for pricing.