

ST FOUNDATION ANCHORS INSTALLATION RECOMMENDATIONS

Properly installed, the *ST Foundation Anchors* are designed primarily to replace the code specified $\frac{1}{2}$ " diameter anchor bolts used to secure the sill plate to concrete or masonry foundations in light frame construction. **The *ST* anchors are designed to simplify the installation of the sill plate because they do not require the locating and drilling of holes for the anchor to pass through.** The *ST* anchors are fabricated from 18 gauge galvanized steel which complies with ASTM A 653 SS Grade 33 specifications, with a G-185 zinc coating.

All four anchors are basically alike. They consist of an upper split flange, a long embedment strap and a hook at the bottom. The hook and embedment strap are embedded into concrete or grout to the depth that the juncture of the

two upper flanges are embedded to about $1\frac{1}{2}$ ". The two upper flanges are field formed to a "Y" spread-width corresponding to the intended sill plate, with the flanges exiting the concrete or grout vertically. After the concrete cures, the sill can be set in place between the two flanges, the flanges field formed over the top of the sill, and the required eight 8d x $1\frac{1}{2}$ " nails (length is $1\frac{1}{2}$ " and diameter = 0.131") installed. **The *ST2-TZ* have longer embedment straps than the *ST1-TZ*.** (See Figure 1)

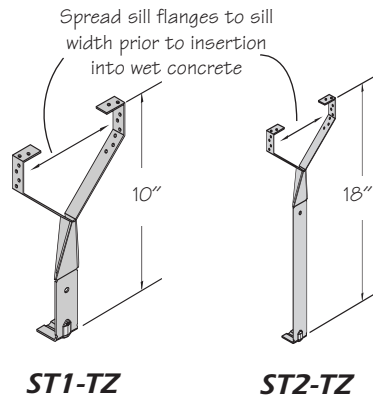

Figure 1

The anchors work best with nominal 2x4 and 2x6 sill plates, but can be used with 2x8 sill plates with a reduction in load and therefore, smaller allowed spacing. They should not be used with larger sill plates unless installed in an alternate installation configuration. **In the alternate configuration, the anchor is embedded in exactly the same manner as described**

above, except the two upper flanges are not spread. Then holes must be drilled in the sill plate and the plate placed over the anchors so both flanges pass through the hole. (See Figure 2) Finally, the flanges are field bent over the wood and secured with eight 8d x $1\frac{1}{2}$ " nails. Alternately installed in this manner, the published load values remain valid, and there is no specific limit on sill size.

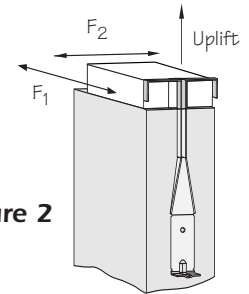
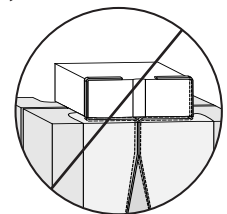

Figure 2

*Alternate **ST1-TZ** installation with $\frac{3}{4}$ " center hole*

In no case, however, shall the anchor be installed with the two upper flanges unbent, and then formed flat against the concrete surface and formed around the sill. (See Figure 3) This does not work because there is too much flexibility in the steel flanges under the sill, and fails to provide a tight connection. Under load, the sill and the structure attached to it could potentially displace excessively.



*DO NOT install **ST1-TZ** and **ST2-TZ** without prebending sill flanges in "Y" configuration*

Figure 3

USP recommends the use of the *ST1-TZ* in poured concrete foundations and slabs, and the *ST2-TZ* in masonry foundations. Where used in masonry, the anchors shall be installed in the grout holes of minimum 8" concrete masonry units. Never install the anchor in the mortar joint or in the end cores of the block. The anchor shall be embedded in grout that fully fills the core of those blocks containing the anchor. There is further masonry discussion in later paragraphs.

The code provision for anchor sill plates is to use $\frac{1}{2}$ " anchor bolts at 6 foot on center spacing, a minimum of two anchors per sill board, and with an anchor within 12" of each end. The code does not, however, quantify the value of the $\frac{1}{2}$ " anchor bolt for the various forces the sill must resist.

continued on back



USP supplies quality products to build Stronger Safer Structures

Customer Service:
Burnsville, MN
Phone: 1-800-328-5934
Fax: 1-507-364-8762

Manufacturing:
Montgomery, MN • Livermore, CA
Largo, FL • North Wilkesboro, NC
Rancho Cucamonga, CA • Thornhill, Ontario

Warehouses:
Houston, TX
Lumberton, NJ

www.USPconnectors.com

Information valid until December 31, 2006.

A GIBRALTAR INDUSTRIES COMPANY

USP186-052

ST FOUNDATION ANCHORS CONT. INSTALLATION RECOMMENDATIONS

We assume there are 3 directions of load forces the anchor must resist: **1)** tension due to uplift forces induced by high winds or seismic events **2)** lateral parallel to the axis of the sill plate, usually due to high winds or seismic events, and **3)** lateral perpendicular to the axis of the sill plate. This last load direction is due to either wind or seismic forces, or earth pressure on the foundation wall.

Using the criteria specified or approved in the building code, we ascertained the allowable design values of the typical 1/2" anchor bolt connection to the wood sill plate in each direction. We also tested and analyzed the ST anchors for each load direction, and rated the spacing based on the ratio or relative strength compared to the anchor bolt. On this basis, we established the spacing for the ST anchors at 5 1/2 feet compared to the use of a 1/2" anchor bolt at 6 feet on center. The limiting value was actually the lateral force parallel to the sill plate.

USP Structural Connectors arranged with Twin City Testing Corporation of St. Paul, Minnesota to test the ST anchors in concrete and masonry. Tests were performed for each of the three load directions. The embedment of the anchor, whether in masonry or concrete, was never the governing factor in any test. Rather, either failure of the connection with the wood or failure of the anchor strap itself governed, but not the masonry or concrete. Thus, there is never an issue with the embedment itself, particularly in concrete, when properly installed. Loads assume the compressive strength of the concrete or grout is a minimum 2,000 psi at 28 days.

Nevertheless, USP recommends the longer ST2 for use with masonry construction. The reason is the device is often installed in un-reinforced masonry. The longer anchor into the core of the top two grouted courses of masonry ensures a stronger bond to

the masonry. Otherwise, there is a potential that the top block breaks free from the lower course. If the bond extends to the second tier, the strength is effectively tripled compared to the embedment only to the top block. It is only necessary to grout the core of the top two blocks to fully encompass the anchor – the core under the two upper blocks need not to be grouted. **However, if installed in reinforced masonry or in a tie or bond beam, the ST1, which extends only to the top tier of block, is also appropriate, and retains full load value.**

Since the sill plate is usually aligned to the perimeter edge of the foundation, one of the upper flanges usually exits the concrete right at the edge. It is therefore necessary, with concrete masonry units, to chip the inner edge of the block at approximately a 45° angle so that the flange can reach the outer edge of the block. The device was tested in concrete grout in masonry or in concrete having a compressive strength of 2,000 psi. USP does not have data to support the use of the anchor embedded in mortar grout.

In regards to fastening to wood framing, provided all eight nails are installed, four on each flange, it is not necessary to form the upper flanges over the sill plate to achieve the published load value. The anchor can be used with double ply 2x sill plates (the 2-plys must be fastened together independent to the anchors to act as a single unit). It can also be used where a rim joist is installed onto the sill – one flange is installed to the sill in the normal way while the other flange extends up the face of the rim (however, the rim shall also be secured to the sill independent of the anchor). The flanges may also extend up the edge of the stud if the stud should happen to align at the point where the anchor was installed in the foundation.

Plate Size	USP Stock No.	Ref. No.	Steel Gauge	Fastener Schedule ²		Min. Embed. ⁴ (E)	Max. Spacing ³ (Feet)	Allowable Loads (Lbs.) ¹							
				Mudsill Top	Mudsill Side			DF-L / SP							
								F1		F2		F3		Uplift	
								133%	160%	133%	160%	133%	160%	133%	160%
2 x 4 - 6	ST1-TZ	MAB15Z	18	(4) 8d x 1-1/2	(4) 8d x 1-1/2	8-1/2"	*5-1/2	565	565	670	745	670	745	825	825
2 x 4 - 6	ST2-TZ	MAB23Z	18	(4) 8d x 1-1/2	(4) 8d x 1-1/2	16-1/2"	*5-1/2	565	565	670	745	670	745	825	825
2 x 4 - 6 - 8	FA3	MAS	16	(4) 10d x 1-1/2	(2) 10d x 1-1/2	4"	5-1/2	840	840	705	705	735	750	1155	1155

1) Allowable loads have been increased 33-1/3% or 60% for wind or seismic loads; no further increase shall be permitted.

2) 10d x 1-1/2 nails are 9 gauge (0.148" diameter) by 1-1/2" long.

8d x 1-1/2 nails are 11 gauge (0.131" diameter) by 1-1/2" long.

3) Anchor spacing and design loads assume treated Douglas Fir-Larch with Fc perpendicular @ 625 psi; replaces code prescribed 1/2" anchor bolt with standard washer, spaced 6 ft. on center.

4) If installed in the alternate configuration, the ST1-TZ shall be embedded 11" and ST2-TZ 19".

*When a 2 x 8 mudsill is used for ST1-TZ or ST2-TZ, maximum spacing is 3 feet unless alternate installation is used.