

See the Specialty Options Chart for each hanger series for load reductions and hanger maximum range of skew, slope, etc.

Skewed Hanger:

- Consider SKH or SKHH hangers for 45° skews.
- Joist nails may be located on obtuse side to ensure proper nailing.
- Specify skew angle, type (A or B), and direction when ordering.

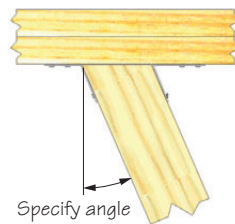

Typical *SUH* hanger skewed, right shown Type A (bevel cut required)

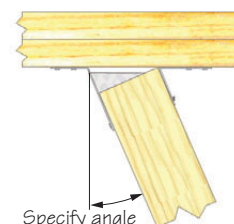

Typical *SUH* formed hanger skewed, right shown Type B

Sloped Seat Hanger:

- Consider LSSH series for sloped applications.
- Additional nail holes may be added to joist flanges.
- Specify slope angle and direction when ordering.

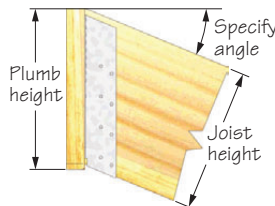

Typical *HD* hanger sloped seat, down shown

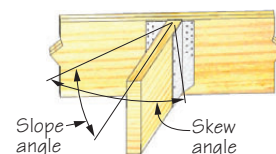

Typical *HD* hanger sloped down, skewed left shown

Sloped/Skewed Hanger:

- See nailing notes for both skewed and sloped hangers.
- Specify skew and slope angles as well as skew/slope directions and skew type (A or B) when ordering.

Inverted Flange Hanger:

- For skewed-only hangers, the flange on the cut side can be inverted at 100% of the table load. Consult USP for skew limitations.
- When nailing into the carrying member's end grain, the allowable load is 0.65 of the table load.
- Hangers with one flange inverted achieve 100% of listed table load.
- Specify right or left flange when inverting only one flange.

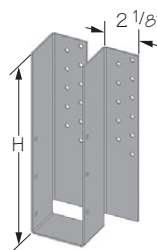

Typical *GHF* hanger one flange inverted, left shown

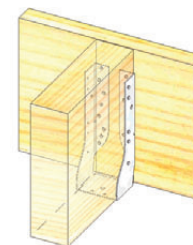

Typical *HD* hanger inverted flange



See Specialty Options Chart for each hanger series for load reductions and hanger maximum range of skew, slope, etc.

Skewed Hanger:

- Joist nails may be located on obtuse side to ensure proper nailing.
- Specify skew angle, type (A or B), and direction when ordering.

Sloped Seat Hanger:

- Additional nail holes may be added to joist flanges.
- Specify slope angle, direction, and joist height when ordering.

Sloped/Skewed Hanger:

- See nailing notes for both skewed and sloped hangers.
- Specify skew and slope angles as well as skew/slope directions, and skew type (A or B) when ordering.
- Similar to face mount skewed/sloped hanger, refer to illustration on page 195: Typical HD hanger sloped down, skewed left shown.
- Specify if hanger is to be high side flush, low side flush, or center flush.

Sloped/Skewed/Sloped Top Flange Hanger:

- See nailing notes for both skewed and sloped hangers.
- Specify skew, slope, and top flange slope angles as well as skew/slope and top flange slope directions when ordering.
- Skewed/sloped/top flange sloped hangers can be made galvanized or painted.

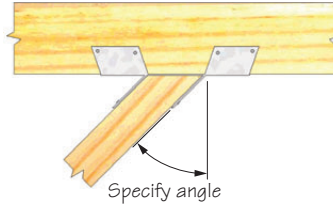

Typical BPH hanger skewed, left shown Type A (bevel cut required)

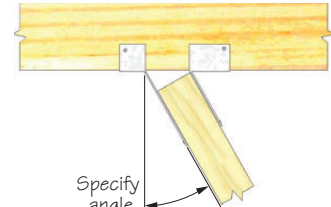

Typical BPH hanger skewed, right shown Type B

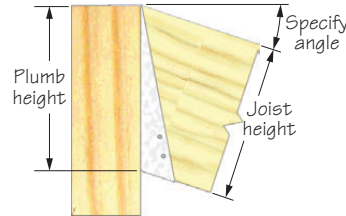

Typical BPH hanger sloped seat, down shown

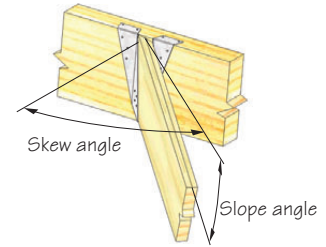

Typical BPH hanger sloped down, skewed right, low side flush shown

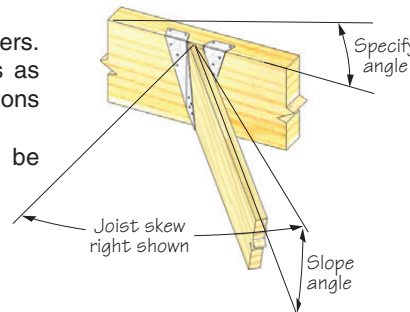

Typical BPH hanger skewed right, sloped down, top flange sloped

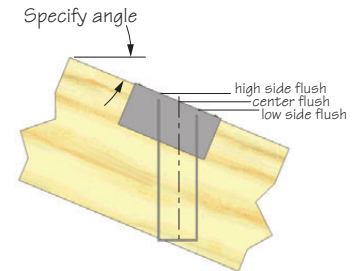

Typical HLBH hanger sloped top flange right shown

© Copyright 2011 USP Structural Connectors®

SOLID TOP FLANGE HANGER SPECIALTY DETAILS

See Specialty Options Chart for each hanger series for load reductions and hanger maximum range of skew, slope, etc.

Skewed Hanger:

- Joist nails may be located on obtuse side to ensure proper nailing.
- Specify skew angle, type (A or B), and direction when ordering.

Sloped Seat Hanger:

- Additional nail holes may be added to joist flanges.
- Specify slope angle, direction, and joist height when ordering.

Sloped/Skewed Hanger:

- See nailing notes for both skewed and sloped hangers.
- Specify skew and slope angles as well as skew/slope directions, and skew type (A or B) when ordering.
- Specify if hanger is to be high side flush, low side flush, or center flush.

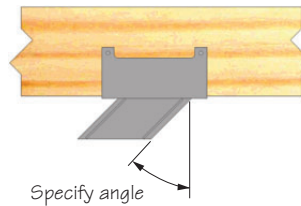

Typical PHXU hanger skewed, left shown Type A (bevel cut required)

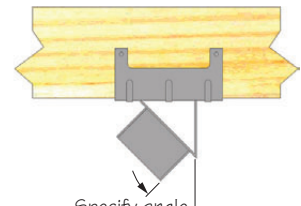

Typical PHXU hanger skewed, left shown Type B

continued on next page

Sloped Top Flange Hanger:

- Additional nail holes may be added to top angle.
- Specify top flange slope and direction when ordering.
- Specify if hanger is to be high side flush, low side flush, or center flush.

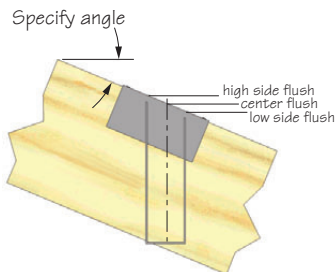

Typical HLBH hanger sloped top flange, right shown

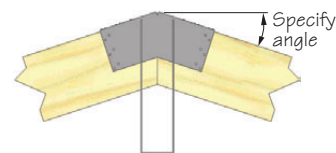

Typical HLBH hanger ridge, top flange slope

Ridge Hanger:

- Specify flush top of beam at center, right side, or left side.
- Specify angle of slope when ordering.

Top Flange Offset Hanger:

- Specify offset, left (L) or right (R), when ordering.

Saddle Hanger:

- Specify saddle width, "SA" when ordering. Allow clearance for saddled member.

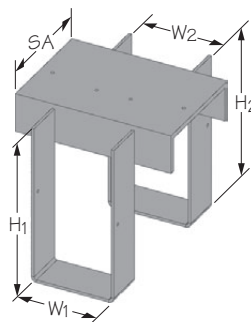

Typical PHXU hanger saddle option

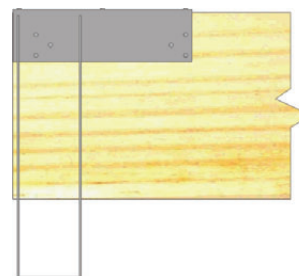

Typical HLBH hanger top flange offset, right shown

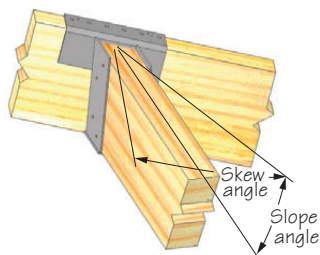

Typical HLBH hanger sloped down, skewed right, low side flush shown

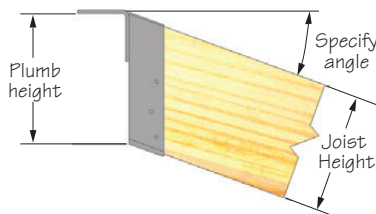

Typical HLBH hanger sloped seat, down shown

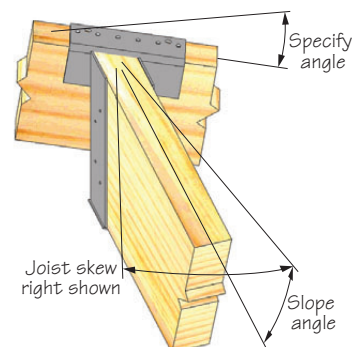

Typical HLBH hanger skewed right, sloped down, top flange sloped

- Weld sizes and lengths shown on chart.
- Weld-on applications produce maximum allowable load listed. **Uplift loads do not apply to this application.**

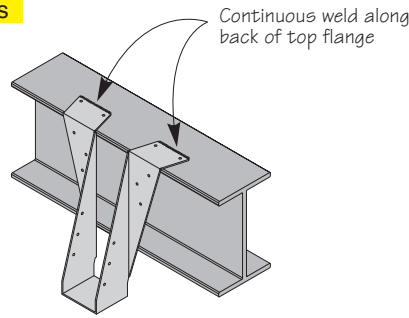

Typical Top Flange welded installation

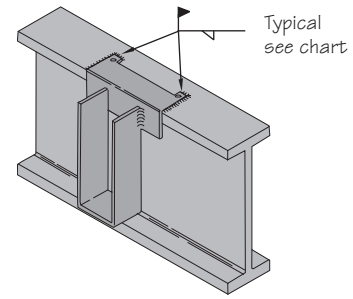

Typical Top Angle welded installation

Top Angle Weld Length chart

USP Welded Hanger Series	Weld Length
SW	3"
BPH, PHM, SWH	4"
KHW, PHXU	6"
KGB, KHGB, KHGB, KGLS, KGLST, KGLT, KHGLS, KHGLST	8"
HLBH, KHGLT	10"

Top Angle Steel Gauge	Weld Size
10 gauge or lighter	1/8"
7 gauge	3/16"
3 gauge	1/4"

Weld shall be distributed evenly.

PART NUMBER SYSTEM

Part Numbers assigned to *TFL*, *THO*, and *THF* I-Joist hangers reveal the I-Joist sizes to be used with the specific hanger. This guide will teach you how to recognize I-Joist dimensions in the part numbers.

1st, 3rd, and sometimes 4th digits are whole numbers
 (This example denotes 2 and 11)
 4th digit may be part of a decimal –
 ex.: THO16925



2nd and 5th digits are decimals
 (see guide below)
 (This example denotes .3125
 [5/16] and .875 [7/8])
 5th digit may be (0) or dropped if
 height is even

Part Number Guide for Decimals

1 = .125	or	1/8 inch
2 or 25 = .25	or	1/4 inch
3 = .3125	or	5/16 inch
5 = .5	or	1/2 inch
6 = .625	or	5/8 inch
7 = .75	or	3/4 inch
8 = .875	or	7/8 inch

THO35925-2

THO 35 925 -2

Letters
refer to
Hanger
Series
ex.: THO

First (2)
Digits
refer to
Member Width
ex.: 3.5 inches

Last (2) or
(3) Digits
refer to
Member Height
ex.: 9.25 inches

Digits after
Dash
refer to
Number of Plys
ex.: 2 ply

Some Examples:

THO159501-1/2" x 9-1/2"
 THF179251-3/4" x 9-1/4"
 THO16925-2double 1-5/8" x 9-1/4"
 THF23140-2double 2-5/16" x 14"

Note: USP's *Full Line Catalog* lists a range of heights for *THF* hangers. Face mount hangers can usually accommodate more than one I-Joist height. The hanger height must be tall enough to support the top chord of the I-Joist to eliminate web stiffener requirements on solid sawn or joists with web stiffeners. The *THF* hanger must be a minimum of 60% of the joist height.