

## FACE MOUNT JOIST HANGERS ..... PAGES 87-95

- **JL Series**  
Light-capacity 20 gauge 2x joist hanger.
- **JLIF-TZ Series**  
Medium-capacity inverted flange 18 gauge joist hanger.
- **SUH Series**  
Medium-capacity 16 gauge joist hanger.
- **JUS Series**  
Medium-capacity 18 gauge joist hanger with slant nailing.
- **MUS Series**  
Medium-capacity 18 gauge joist hanger with slant nailing.
- **HUS Series**  
Heavy-capacity 14 or 16 gauge joist hanger with slant nailing.
- **HD Series**  
Heavy-capacity 14 gauge inverted flange joist hanger.
- **HDQ Series**  
Heavy-capacity 14 gauge inverted flange joist hanger.

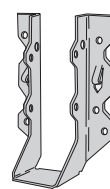

*JL*



*JLIF-TZ*

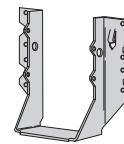

*SUH*



*JUS  
MUS Similar*

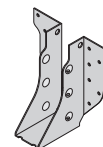

*HUS*



*HD*

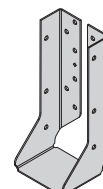

*HDQ*

## TOP MOUNT HANGERS ..... PAGES 96-101

- **HDO Series**  
Medium-capacity 12 gauge top mount hanger with uplift capacity.
- **SW Series**  
Light-capacity welded hanger with primer finish.
- **SWH Series**  
Medium-capacity welded hanger with primer finish.
- **KHW Series**  
Heavy-capacity welded hanger with primer finish.
- **HL Series**  
Light-capacity 18 gauge 2x top mount hanger.
- **JH Series**  
Medium-capacity strap style hanger.

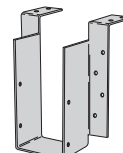

*HDO*

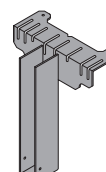

*SW*

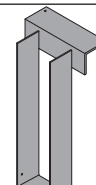

*SWH*

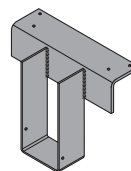

*KHW*

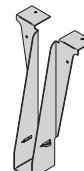

*HL*

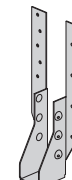

*JH*

## SLOPE & SKEW HANGERS .... PAGES 101-103

- **LS Series**  
Light-capacity hanger for slopes of 0° to 30° down.
- **SKH Series**  
Light-capacity 45° skewed hanger.
- **SKHH Series**  
Medium-capacity 45° skewed hanger.

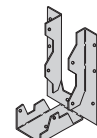

*LS*

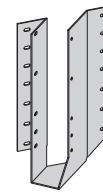

*SKH*

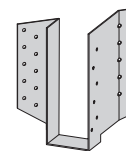

*SKHH*

© Copyright 2011 USP Structural Connectors®

Hangers

continued on next page

## PANEL & PURLIN HANGERS . . . . . PAGES 104-105

- **KF Series**  
Panel hanger with a joist end nail.
- **PHG Series**  
Panel hanger that uses a gripper instead of a nail.
- **JDS Series**  
Medium-capacity purlin saddle hanger.
- **JPF Series**  
Medium-capacity purlin hanger with double shear nailing.

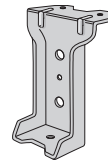

*KF*

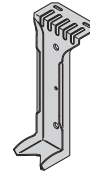

*PHG*

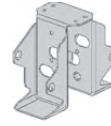

*JDS*

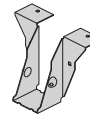

*JPF*

## MASONRY HANGERS . . . . . PAGES 106-110

- **HWUH Series**  
Heavy-capacity top flange masonry hanger.
- **MPH Series**  
Top flange masonry hanger.
- **UMH Series**  
Face mount masonry hanger.
- **NFM Series**  
Narrow flange hanger for headers connecting to the end of a masonry wall.

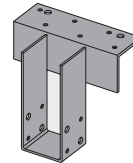

*HWUH*

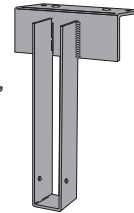

*MPH*

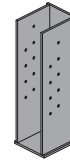

*UMH*

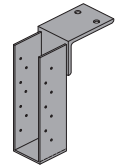

*NFM*

USP offers a wide variety of light-gauge face mount joist hangers to accommodate application and installation preferences.

**JL series** – 20 gauge, 2x joist hangers.

**JL-IF series** – 18 gauge, 2x joist hangers.

**SUH series** – 16 gauge steel construction for more demanding applications and light truss support.

**Materials:** See chart

**Finish:** G90 galvanizing

**Options:** See SUH Specialty Options Chart.

**Codes:** ESR-1781, ESR-1280, L.A. City RR 25749,  
**L.A. City RR 25843**, FL571, FL11664, **FL13285**,  
 Dade County, FL 07.0214.20

**Installation:**

- Use all specified fasteners. See Product Notes, page 11.

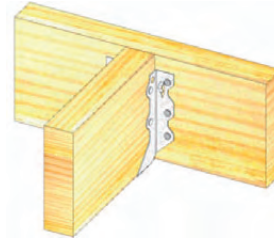

Typical **JL26** installation

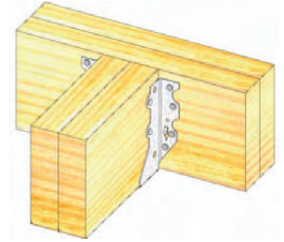

Typical **SUH26-2** installation



**JL26**

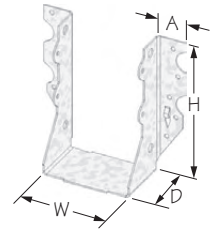

**SUH26-2**

**SUH Specialty Options Chart** – refer to Specialty Options pages 194 to 195 for additional details.

Option <sup>4</sup>	Skewed <sup>1,3</sup>	Sloped Seat <sup>2,3</sup>	Sloped / Skewed <sup>1,2,3</sup>
Range	1' to 67-1/2' when width is 1-3/4" or less. 1' to 50' on all others.	1' to 45'	See Sloped Seat and Skewed
Allowable Loads	100% of table load. 75% of uplift load on skews greater than 15'.	100% of table load	80% of table load. 75% of uplift load on skews greater than 15'.
Ordering	Add SK angle required, and right (R) or left (L), to product number. Ex. SUH210-SK45R	Add SL, slope required, and up (U) or down (D), to product number. Ex. SUH210-SL30D	See Sloped Seat and Skewed. Ex. SUH210-SK45RSL30D

- 1) Skewed hangers with skews greater than 15° may have all joist nailing on outside flange.
- 2) Sloped or sloped / skewed hangers with slopes greater than 15° may have additional joist nails.
- 3) All sloped, skewed, or combinations require bevel cut on joist in all applications and web stiffeners with I-Joists.
- 4) Some SUH option hangers may be manufactured as welded products to achieve listed loads.

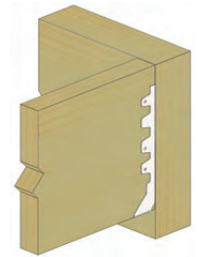

Typical **JL-IF** installation



**JL-IF**

© Copyright 2011 USP Structural Connectors®

The HUS, JUS & MUS hanger series offers double shear nailing. USP's dimple allows for 30° to 45° nailing through the joist into the header resulting in higher loads and less nailing. Slant nailing also eliminates the need for shorter joist nails in 2x applications.

- Materials:** JUS - 18 gauge; MUS - 18 gauge; HUS - 14 or 16 gauge
- Finish:** G90 galvanizing;  
JUS24-GC, JUS26-GC, JUS210-GC, JUS26-2GC, & JUS210-2GC – Gold Coat
- Options:** HUS28-2IF, HUS210-2IF, JUS24, JUS26, JUS26-2, JUS28, JUS28-2, JUS210, JUS210-2, JUS44, JUS46, JUS28-3, & JUS210-3 are available in Triple Zinc. To order, add **TZ** to stock number, as in **JUS24 -TZ**.  
JUS24, JUS26, JUS26-2, JUS28, JUS210, and JUS210-2 are available in Stainless Steel. To order, add **SS** to stock number, as in **JUS26-SS**.  
See HUS Specialty Options Chart.
- Codes:** ESR-1881, FL9835, FL570, FL821, FL571,  
Dade County, FL 07-0419.01, Dade County, FL 07-0214.20 &  
Dade County, FL 06-0921.05, **L.A. City RR 25779**

**Installation:**

- Use all specified fasteners. See Product Notes, page 11.
- Joist nails must be driven at a 30° to 45° angle through the joist or truss into the header to achieve listed loads. **Standard length “double shear” nails must be used to achieve listed load values.**
- JUS & MUS - 16d sinkers (9 gauge x 3 1/4”) may be used where 10d commons are specified with no load reduction.

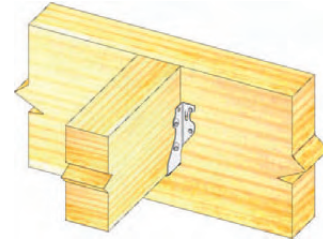

**Typical JUS46 installation**

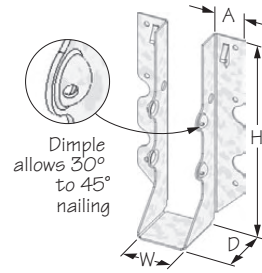

**JUS28**

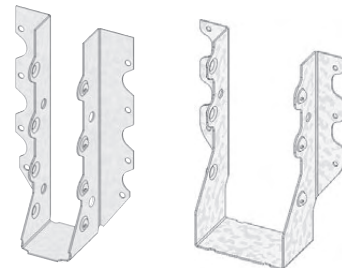

**MUS**

**HUS28-2**

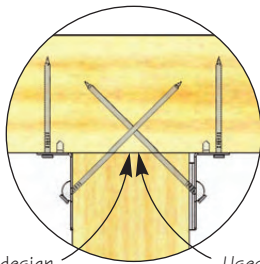

Double shear nail design features fewer nails and faster installation

Uses standard length nails

**AVAILABLE IN  
GOLD  
COAT**

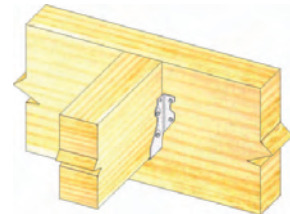

**Typical HUS46 installation**

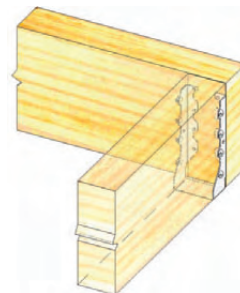

**Typical HUS410IF inverted flange installation**

**HUS Specialty Options Chart** – refer to Specialty Options pages 194-195 for additional details.

Option	Inverted Flange
Range	Not available in widths less than 2-1/4”.
Allowable Loads	100% of table load. 65% of table load when nailing into the support members end grain.
Ordering	Add IF to product number. Ex. HUS410IF

HD hangers are heavy-duty face mount hangers that can be used to support headers, joists, and trusses.

- Materials:** 14 gauge
- Finish:** G90 galvanizing
- Options:** All nominal lumber sizes are available rough/full size lumber. See Specialty Options Chart.
- Codes:** ESR-1781, **FL13285**, L.A. City RR 25843

**Installation:**

- Use all specified fasteners. See Product Notes, page 11.
- Some HD models feature nail holes along bend line that must be filled to achieve allowable loads. Verify proper header width to accomplish this for inverted models.

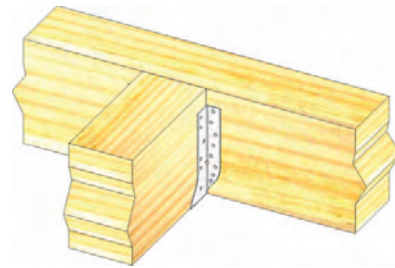
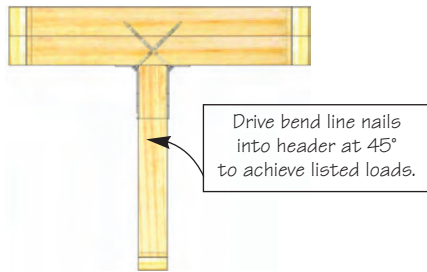

**Typical HD610 installation**

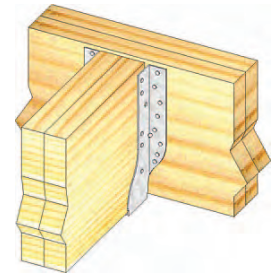

**Typical HD210-2 installation**

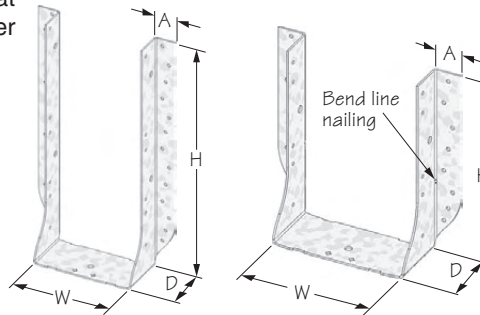

**HD51135**

**HD610**

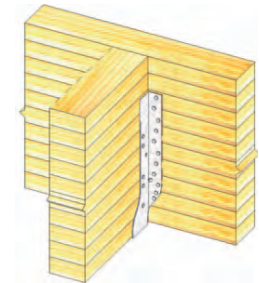

**Typical HD3212 glulam installation**

**Specialty Options Chart** – refer to Specialty Options pages 194 to 195 for additional details.

Option <sup>1</sup>	Skewed <sup>1,3</sup>	Sloped Seat <sup>2,3</sup>	Sloped / Skewed <sup>1,2,3</sup>	Inverted Flange
Range	1' to 67-1/2' when width is 1-3/4" or less. 1' to 50' on all others.	1' to 45'	See Sloped Seat and Skewed	Not available in widths less than 2-1/4"
Allowable Loads	100% of table load. 75% of uplift load on skews greater than 15'.	100% of table load	80% of table load. 75% of uplift load on skews greater than 15'.	100% of table load. 65% of table load when nailing into the support members end grain.
Ordering	Add SK, angle required, and right (R) or left (L), to product number. Ex. HD410-SK45R	Add SL, slope required, and up (U) or down (D), to product number. Ex. HD410-SL30D	See Sloped Seat and Skewed. Ex. HD410-SK45RSL30D	Add IF to product number. Ex. HD410IF

1) Skewed hangers with skews greater than 15° may have all joist nailing on outside flange.  
 2) Sloped or sloped / skewed hangers with slopes greater than 15° may have additional joist nails.  
 3) All sloped, skewed, or combinations require bevel cut on joist in all applications and web stiffeners with I-joists.  
 Hangers for square-cut joists are available as a Custom. Further reductions in allowable loads may apply.  
 4) Modifications of HD hangers may be manufactured as hot rolled, welded, or primed.  
 New products or updated product information are designated in bold font.

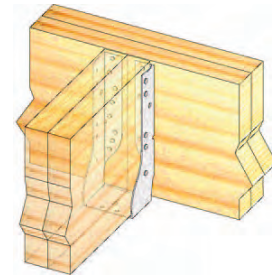

**Typical HD210-2IF inverted flange installation**

## INVERTED FLANGE HANGERS – HDQ SERIES

HDQ inverted flange hangers install with wood screws eliminating the need to drill bolt holes simplifying installation.

- Materials:** 14 gauge
- Finish:** G90 galvanizing

**Installation:**

- Use all specified fasteners. See Product Notes, page 11.
- WS15 and WS3 Wood Screws are supplied with HDQ hangers.

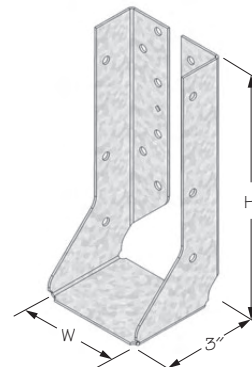

**HDQ-IF**

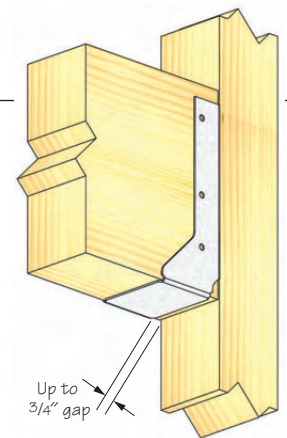

**Typical HDQ-IF installation**

**Hangers**

Joist Size	USP Stock No.	Ref. No.	Steel Gauge	Dimensions				Fastener Schedule <sup>2,3,4,6,7</sup>				Allowable Loads (Lbs.)				Code Ref.
				W	H	D	A	Header		Joist		DF-L / SP				
								Qty	Nail	Qty	Nail	Floor	Roof		Uplift <sup>1</sup>	
				100%	115%	125%	160%									
2 x 4	JL24	LU24	20	1-9/16	3	1-1/2	15/16	4	10d	2	10d x 1-1/2	455	525	570	245	5, F6,
			20	1-9/16	3	1-1/2	15/16	4	16d	2	10d x 1-1/2	545	625	680	245	F30, D3, R5
	JL24IF-TZ	---	18	1-9/16	3-1/8	1-1/2	---	4	10d	2	10d x 1-1/2	465	480	480	305	110
			18	1-9/16	3-1/8	1-1/2	---	4	16d	2	10d x 1-1/2	480	480	480	305	
	JUS24	LUS24	18	1-9/16	3-1/8	1-3/4	1	4	10d	2	10d	655	750	820	510	6, F6,
	JUS24-GC	---	18	1-9/16	3-1/8	1-3/4	1	4	N10C-GC	2	N10C-GC	655	750	820	510	F15, D3, R13
2 x 6	SUH24	U24	16	1-9/16	3-1/4	2	1-3/16	4	10d	2	10d x 1-1/2	465	535	580	360	2, F20,
			16	1-9/16	3-1/4	2	1-3/16	4	16d	2	10d x 1-1/2	550	635	690	360	R12
	HD26	HU26	14	1-9/16	3-1/2	2	1-1/8	4	16d	2	10d x 1-1/2	565	650	705	290	5, F30, R5
	JL26	LU26	20	1-9/16	4-3/4	1-1/2	15/16	6	10d	4	10d x 1-1/2	685	785	855	485	5, F6,
			20	1-9/16	4-3/4	1-1/2	15/16	6	16d	4	10d x 1-1/2	815	940	1020	485	F30, D3, R5
	JL26IF-TZ	LUC26Z	18	1-9/16	4-1/2	1-1/2	---	6	10d	4	10d x 1-1/2	695	800	870	730	110
			18	1-9/16	4-1/2	1-1/2	---	6	16d	4	10d x 1-1/2	830	950	1035	730	
	JUS26	LUS26	18	1-9/16	4-13/16	1-3/4	1	4	10d	4	10d	850	975	1060	1115	6, F6,
	JUS26-GC	---	18	1-9/16	4-13/16	1-3/4	1	4	N10C-GC	4	N10C-GC	850	975	1060	1115	F15, D3, R13
	MUS26	MUS26	18	1-9/16	5-1/16	2	1	6	10d	6	10d	1285	1475	1605	865	110
			16	1-9/16	5-1/8	2	1-3/16	6	10d	4	10d x 1-1/2	695	800	870	725	2, F20,
			16	1-9/16	5-1/8	2	1-3/16	6	16d	4	10d x 1-1/2	830	950	1035	725	R12
2 x 8	HUS26	HUS26	16	1-5/8	5-7/16	3	2	14	16d	6	16d	2635	3030	3295	1925	6, F15, F18, D2, R13
	HD26	HU26	14	1-9/16	3-1/2	2	1-1/8	4	16d	2	10d x 1-1/2	565	650	705	290	5, F30, R5
	HD28	HU28	14	1-9/16	5-1/4	2	1-1/8	8	16d	4	10d x 1-1/2	1130	1295	1410	730	
	JL26	LU26	20	1-9/16	4-3/4	1-1/2	15/16	6	10d	4	10d x 1-1/2	685	785	855	485	5, F6,
			20	1-9/16	4-3/4	1-1/2	15/16	6	16d	4	10d x 1-1/2	815	940	1020	485	F30, D3, R5
	JL26IF-TZ	LUC26Z	18	1-9/16	4-1/2	1-1/2	---	6	10d	4	10d x 1-1/2	695	800	870	730	110
			18	1-9/16	4-1/2	1-1/2	---	6	16d	4	10d x 1-1/2	830	950	1035	730	
	JL28	LU28	20	1-9/16	6-3/8	1-1/2	15/16	10	10d	6	10d x 1-1/2	1140	1295	1295	885	5, F6,
			20	1-9/16	6-3/8	1-1/2	15/16	10	16d	6	10d x 1-1/2	1360	1565	1700	885	F30, D3, R5
	JL28IF-TZ	LUC28Z	18	1-9/16	6-1/8	1-1/2	---	8	10d	4	10d x 1-1/2	930	1065	1160	730	110
			18	1-9/16	6-1/8	1-1/2	---	8	16d	4	10d x 1-1/2	1105	1215	1215	730	
	JUS26	LUS26	18	1-9/16	4-13/16	1-3/4	1	4	10d	4	10d	850	975	1060	1115	6, F6,
	JUS26-GC	---	18	1-9/16	4-13/16	1-3/4	1	4	N10C-GC	4	N10C-GC	850	975	1060	1115	F15, D3, R13
	JUS28	LUS28	18	1-9/16	6-5/8	1-3/4	1	6	10d	4	10d	1075	1235	1345	1115	
	JUS28-GC	---	18	1-9/16	6-5/8	1-3/4	1	6	N10C-GC	4	N10C-GC	1075	1235	1345	1115	
	MUS26	MUS26	18	1-9/16	5-1/16	2	1	6	10d	6	10d	1285	1475	1605	865	110
	MUS28	MUS28	18	1-9/16	7-1/16	2	1	8	10d	8	10d	1710	1970	2140	1230	
	SUH26	U26	16	1-9/16	5-1/8	2	1-3/16	6	10d	4	10d x 1-1/2	695	800	870	725	2, F20,
		16	1-9/16	5-1/8	2	1-3/16	6	16d	4	10d x 1-1/2	830	950	1035	725	R12	
SUH28	---	16	1-9/16	6-5/8	2	1-3/16	8	10d	6	10d x 1-1/2	930	1065	1160	800		
		16	1-9/16	6-5/8	2	1-3/16	8	16d	6	10d x 1-1/2	1105	1270	1380	800		
HUS26	HUS26	16	1-5/8	5-7/16	3	2	14	16d	6	16d	2635	3030	3295	1925	6, F15, F18, D2, R13	
HUS28	HUS28	16	1-5/8	7-3/16	3	2	22	16d	8	16d	3970	4345	4345	2570		
HD28	HU28	14	1-9/16	5-1/4	2	1-1/8	8	16d	4	10d x 1-1/2	1130	1295	1410	730	5, F30, R5	
HD210	HU210	14	1-9/16	7-3/16	2	1-1/8	12	16d	4	10d x 1-1/2	1690	1945	2115	730		
2 x 10	JL28	LU28	20	1-9/16	6-3/8	1-1/2	15/16	10	10d	6	10d x 1-1/2	1140	1295	1295	885	5, F6,
			20	1-9/16	6-3/8	1-1/2	15/16	10	16d	6	10d x 1-1/2	1360	1565	1700	885	F30, D3, R5
	JL28IF-TZ	LUC28Z	18	1-9/16	6-1/8	1-1/2	---	8	10d	4	10d x 1-1/2	930	1065	1160	730	110
			18	1-9/16	6-1/8	1-1/2	---	8	16d	4	10d x 1-1/2	1105	1215	1215	730	
	JL210	LU210	20	1-9/16	8-1/4	1-1/2	15/16	14	10d	8	10d x 1-1/2	1595	1835	1875	1095	5, F6,
			20	1-9/16	8-1/4	1-1/2	15/16	14	16d	8	10d x 1-1/2	1905	1965	1965	1095	F30, D3, R5
	JL210IF-TZ	LUC210Z	18	1-9/16	8-1/4	1-1/2	---	11	10d	6	10d x 1-1/2	1275	1465	1595	1095	110
			18	1-9/16	8-1/4	1-1/2	---	11	16d	6	10d x 1-1/2	1520	1745	1900	1095	
	JUS28	LUS28	18	1-9/16	6-5/8	1-3/4	1	6	10d	4	10d	1075	1235	1345	1115	6, F6,
	JUS28-GC	---	18	1-9/16	6-5/8	1-3/4	1	6	N10C-GC	4	N10C-GC	1075	1235	1345	1115	F15, D3, R13
	JUS210	LUS210	18	1-9/16	7-3/4	1-3/4	1	8	10d	4	10d	1305	1500	1630	1115	
	JUS210-GC	---	18	1-9/16	7-3/4	1-3/4	1	8	N10C-GC	4	N10C-GC	1305	1500	1630	1115	
	MUS28	MUS28	18	1-9/16	7-1/16	2	1	8	10d	8	10d	1710	1970	2140	1230	110
	SUH28	---	16	1-9/16	6-5/8	2	1-3/16	8	10d	6	10d x 1-1/2	930	1065	1160	800	2, F20,
			16	1-9/16	6-5/8	2	1-3/16	8	16d	6	10d x 1-1/2	1105	1270	1380	800	R12
	SUH210	U210	16	1-9/16	8	2	1-3/16	10	10d	6	10d x 1-1/2	1160	1335	1450	1085	
			16	1-9/16	8	2	1-3/16	10	16d	6	10d x 1-1/2	1380	1585	1725	1085	
	HUS28	HUS28	16	1-5/8	7-3/16	3	2	22	16d	8	16d	3970	4345	4345	2570	6, F15, F18, D2, R13
HUS210	HUS210	16	1-5/8	9-3/16	3	2	30	16d	10	16d	5310	5510	5510	3205		
HD210	HU210	14	1-9/16	7-3/16	2	1-1/8	12	16d	4	10d x 1-1/2	1690	1945	2115	730	5, F30, R5	

- 1) Uplift loads have been increased 60% for wind or seismic loads; no further increase shall be permitted.
- 2) 10d x 1-1/2 nails are 9 gauge (0.148" diameter) by 1-1/2" long.
- 3) Minimum nail embedment shall be 1-1/2" for 10d and N10C-GC nails; 1-5/8" for 16d and N16C-GC nails.
- 4) 16d sinkers (9 gauge x 3-1/4" long) may be used at 0.84 of the table load where 16d commons are specified.
- 5) For JUS and HUS hangers: Nails must be driven at a 30° to 45° angle through the joist or truss into the header to achieve the table loads.
- 6) WS15 Wood Screws are 1-1/4" x 1-1/2" long and are included with HDQ hangers.
- 7) WS3 Wood Screws are 1-1/4" x 3" long and are included with HDQ hangers.

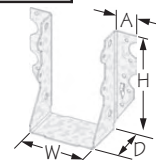

# FACE MOUNT HANGER CHARTS CONTINUED



©Copyright 2011 USP Structural Connectors®

Hangers

Joist Size	USP Stock No.	Ref. No.	Steel Gauge	Dimensions				Fastener Schedule <sup>2,3,4,6,7</sup>				Allowable Loads (Lbs.)				Code Ref.
				W	H	D	A	Header		Joist		DF-L / SP				
								Qty	Nail	Qty	Nail	Floor	Roof		Uplift <sup>1</sup>	
100%	115%	125%	160%													
2 x 12	JL210	LU210	20	1-9/16	8-1/4	1-1/2	15/16	14	10d	8	10d x 1-1/2	1595	1835	1875	1095	5, F6, F30, D3, R5
			20	1-9/16	8-1/4	1-1/2	15/16	14	16d	8	10d x 1-1/2	1905	1965	1965	1095	
	JL210IF-TZ	LUC210Z	18	1-9/16	8-1/4	1-1/2	---	11	10d	6	10d x 1-1/2	1275	1465	1595	1095	110
			18	1-9/16	8-1/4	1-1/2	---	11	16d	6	10d x 1-1/2	1520	1745	1900	1095	
	JUS210	LUS210	18	1-9/16	7-3/4	1-3/4	1	8	10d	4	10d	1305	1500	1630	1115	6, F6, F15, D3, R13
	JUS210-GC	---	18	1-9/16	7-3/4	1-3/4	1	8	N10C-GC	4	N10C-GC	1305	1500	1630	1115	
	SUH210	U210	16	1-9/16	8	2	1-3/16	10	10d	6	10d x 1-1/2	1160	1335	1450	1085	2, F20, R12
			16	1-9/16	8	2	1-3/16	10	16d	6	10d x 1-1/2	1380	1585	1725	1085	
	HUS210	HUS210	16	1-5/8	9-3/16	3	2	30	16d	10	16d	5310	5510	5510	3205	6, F15, F18, D2, R13
	HD210	HU210	14	1-9/16	7-3/16	2	1-1/8	12	16d	4	10d x 1-1/2	1690	1945	2115	730	5, F30, R5
	HD212	HU212	14	1-9/16	9-1/4	2	1-1/8	16	16d	6	10d x 1-1/2	2255	2595	2730	1065	
2 x 14	SUH214	U214	16	1-9/16	10	2	1-1/8	12	10d	8	10d x 1-1/2	1390	1600	1740	1330	2, F20, R12
			16	1-9/16	10	2	1-1/8	12	16d	8	10d x 1-1/2	1655	1905	2070	1330	
	HD212	HU212	14	1-9/16	9-1/4	2	1-1/8	16	16d	6	10d x 1-1/2	2255	2595	2730	1065	5, F30, R5
	HD214	HU214	14	1-9/16	11-1/2	2	1-1/8	20	16d	6	10d x 1-1/2	2560	2660	2730	1065	
2 x 16	SUH214	U214	16	1-9/16	10	2	1-1/8	12	10d	8	10d x 1-1/2	1390	1600	1740	1330	2, F20, R12
			16	1-9/16	10	2	1-1/8	12	16d	8	10d x 1-1/2	1655	1905	2070	1330	
	HD212	HU212	14	1-9/16	9-1/4	2	1-1/8	16	16d	6	10d x 1-1/2	2255	2595	2730	1065	5, F30, R5
	HD214	HU214	14	1-9/16	11-1/2	2	1-1/8	20	16d	6	10d x 1-1/2	2560	2660	2730	1065	
(2) 2 x 4	JUS24-2	LUS24-2	18	3-1/8	3-7/16	2	1	4	16d	2	16d	780	900	965	325	6, F5, R13
			16	3-1/8	3-1/8	2	1-1/8	6	10d	2	10d	695	800	870	370	2, F20, R12
	SUH24-2	U24-2	16	3-1/8	3-1/8	2	1-1/8	6	16d	2	10d	830	950	1035	370	
			14	3-1/8	3-1/2	2-1/2	1-1/8	4	16d	2	10d	565	650	705	320	5, F30, R5
	HUS24-2	---	14	3-1/8	3-7/16	2	1	4	16d	2	16d	800	920	1000	495	6, F15, R13
(2) 2 x 6	JUS26-2	LUS26-2	18	3-1/8	5-1/4	2	1	4	16d	4	16d	1015	1170	1220	1355	6, F5, F15, D7, R13
	JUS26-2GC	---	18	3-1/8	5-1/4	2	1	4	N16C-GC	4	N16C-GC	1015	1170	1220	1355	
	SUH26-2	U26-2	16	3-1/8	5-1/16	2	1-1/8	8	10d	4	10d	930	1065	1160	740	2, F20, R12
			16	3-1/8	5-1/16	2	1-1/8	8	16d	4	10d	1105	1270	1380	740	
	HD24-2	HU24-2	14	3-1/8	3-1/2	2-1/2	1-1/8	4	16d	2	10d	565	650	705	320	5, F30, R5
			14	3-1/8	3-7/16	2	1	4	16d	2	16d	800	920	1000	495	6, F15, R13
	HUS26-2	HUS26-2	14	3-1/8	5-1/4	2	1	4	16d	4	16d	1030	1185	1290	1115	6, F18, F15, D2, R13
	HD26-2	HU26-2	14	3-1/8	5-1/8	2-1/2	1-1/8	12	16d	6	10d	1690	1945	2095	1140	5, F30, R5
(2) 2 x 8	JUS26-2	LUS26-2	18	3-1/8	5-1/4	2	1	4	16d	4	16d	1015	1170	1220	1355	6, F5, F15, D7, R13
	JUS26-2GC	---	18	3-1/8	5-1/4	2	1	4	N16C-GC	4	N16C-GC	1015	1170	1220	1355	
	JUS28-2	LUS28-2	18	3-1/8	7-1/8	2	1	6	16d	4	16d	1290	1485	1615	1355	
	SUH26-2	U26-2	16	3-1/8	5-1/16	2	1-1/8	8	10d	4	10d	930	1065	1160	740	2, F20, R12
			16	3-1/8	5-1/16	2	1-1/8	8	16d	4	10d	1105	1270	1380	740	
	SUH28-2	---	16	3-1/8	6-1/4	2	1-1/8	10	10d	4	10d	1160	1335	1450	740	
			16	3-1/8	6-1/4	2	1-1/8	10	16d	4	10d	1380	1585	1725	740	
	HUS26-2	HUS26-2	14	3-1/8	5-1/4	2	1	4	16d	4	16d	1030	1185	1290	1115	6, F18, F15, D2, R13
	HUS28-2	HUS28-2	14	3-1/8	7-1/8	2	1	6	16d	6	16d	1550	1780	1935	1810	
	HD26-2	HU26-2	14	3-1/8	5-1/8	2-1/2	1-1/8	12	16d	6	10d	1690	1945	2095	1140	5, F30, R5
	HD28-2	HU28-2	14	3-1/8	7-1/8	2-1/2	1-1/8	14	16d	6	10d	1975	2270	2470	1140	
(2) 2 x 10	JUS28-2	LUS28-2	18	3-1/8	7-1/8	2	1	6	16d	4	16d	1290	1485	1615	1355	6, F5, F15, D7, R13
	JUS210-2	LUS210-2	18	3-1/8	9-1/8	2	1	8	16d	6	16d	1800	2070	2250	1980	
	JUS210-2GC	---	18	3-1/8	9-1/8	2	1	8	N16C-GC	6	N16C-GC	1800	2070	2250	1980	
	SUH28-2	---	16	3-1/8	6-1/4	2	1-1/8	10	10d	4	10d	1160	1335	1450	740	2, F20, R12
			16	3-1/8	6-1/4	2	1-1/8	10	16d	4	10d	1380	1585	1725	740	
	SUH210-2	U210-2	16	3-1/8	8-9/16	2	1-1/8	14	10d	6	10d	1625	1870	2030	1115	
			16	3-1/8	8-9/16	2	1-1/8	14	16d	6	10d	1930	2220	2415	1115	
	HUS28-2	HUS28-2	14	3-1/8	7-1/8	2	1	6	16d	6	16d	1550	1780	1935	1810	6, F18, F15, D2, R13
	HD28-2	HU28-2	14	3-1/8	7-1/8	2-1/2	1-1/8	14	16d	6	10d	1975	2270	2470	1140	5, F30, R5
	HUS210-2	HUS210-2	14	3-1/8	9-1/8	2	1	8	16d	8	16d	2065	2375	2580	2210	6, F18, F15, D2, R13
	HD210-2	HU210-2	14	3-1/8	9	2-1/2	1-1/8	18	16d	10	10d	2540	2920	3175	1905	5, F30, R5
	HU210-2	HUC210-2-SDS	14	3-1/4	9	3	1-1/2	12	WS3	6	WS3	5015	5590	5590	2975	110

continued on next page

Joist Size	USP Stock No.	Ref. No.	Steel Gauge	Dimensions				Fastener Schedule <sup>2,3,4,6,7</sup>				Allowable Loads (Lbs.)				Code Ref.
				W	H	D	A	Header		Joist		DF-L / SP				
								Qty	Nail	Qty	Nail	Floor	Roof		Uplift <sup>1</sup>	
				100%	115%	125%	160%									
(2) 2 x 12	JUS210-2	LUS210-2	18	3-1/8	9-1/8	2	1	8	16d	6	16d	1800	2070	2250	1980	6, F5, F15, D7, R13
	JUS210-2GC	-- --	18	3-1/8	9-1/8	2	1	8	N16C-GC	6	N16C-GC	1800	2070	2250	1980	
	SUH210-2	U210-2	16	3-1/8	8-9/16	2	1-1/8	14	10d	6	10d	1625	1870	2030	1115	2, F20, R12
			16	3-1/8	8-9/16	2	1-1/8	14	16d	6	10d	1930	2220	2415	1115	
	HUS210-2	HUS210-2	14	3-1/8	9-1/8	2	1	8	16d	8	16d	2065	2375	2580	2210	6, F18, F15, D2, R13
	HD210-2	HU210-2	14	3-1/8	9	2-1/2	1-1/8	18	16d	10	10d	2540	2920	3175	1905	5, F30, R5
	HDO210-2IF	HUCQ210-2-SDS	14	3-1/4	9	3	1-1/2	12	WS3	6	WS3	5015	5590	5590	2975	110
(2) 2 x 14	JUS210-2	LUS210-2	18	3-1/8	9-1/8	2	1	8	16d	6	16d	1800	2070	2250	1980	6, F5, F15, D7, R13
	JUS214-2	-- --	18	3-1/8	13-1/8	2	1	12	16d	6	16d	2345	2700	2935	1980	6, F15
	SUH210-2	U210-2	16	3-1/8	8-9/16	2	1-1/8	14	10d	6	10d	1625	1870	2030	1115	2, F20, R12
			16	3-1/8	8-9/16	2	1-1/8	14	16d	6	10d	1930	2220	2415	1115	
	HD210-2	HU210-2	14	3-1/8	9	2-1/2	1-1/8	18	16d	10	10d	2540	2920	3175	1905	5, F30, R5
	HDO210-2IF	HUCQ210-2-SDS	14	3-1/4	9	3	1-1/2	12	WS3	6	WS3	5015	5590	5590	2975	110
	HUS212-2	HUS212-2	14	3-1/8	11-1/8	2	1	10	16d	10	16d	2580	2965	3225	3060	6, F18, F15, D2, R13
(2) 2 x 16	HD212-2	HU212-2	14	3-1/8	11	2-1/2	1-1/8	22	16d	10	10d	3100	3565	3880	1905	5, F30, R5
	HD214-2	HU214-2	14	3-1/8	13	2-1/2	1-1/8	24	16d	10	10d	3385	3890	4230	1905	
	JUS214-2	-- --	18	3-1/8	13-1/8	2	1	12	16d	6	16d	2345	2700	2935	1980	6, F15, R13
	HD212-2	HU212-2	14	3-1/8	11	2-1/2	1-1/8	22	16d	10	10d	3100	3565	3880	1905	
	HD214-2	HU214-2	14	3-1/8	13	2-1/2	1-1/8	24	16d	10	10d	3385	3890	4230	1905	5, F30, R5
	HD216-2	HU216-2	14	3-1/8	15	2-1/2	1-1/8	26	16d	12	10d	3665	4215	4570	2285	
	SUH34	U34	16	2-9/16	3-3/8	2	1-1/8	6	10d	2	10d x 1-1/2	695	800	850	360	2, F20, R12
3 x 4			16	2-9/16	3-3/8	2	1-1/8	6	16d	2	10d x 1-1/2	830	850	850	360	
	HD34	HU34	14	2-9/16	3	2	1-1/8	4	16d	2	10d x 1-1/2	565	650	705	290	5, F30, R5
	JUS36	LUS36	18	2-9/16	5-5/16	2	1	4	16d	4	16d	1015	1170	1220	1355	6, F15, R13
3 x 6	SUH34	U34	16	2-9/16	3-3/8	2	1-1/8	6	10d	2	10d x 1-1/2	695	800	850	360	
			16	2-9/16	3-3/8	2	1-1/8	6	16d	2	10d x 1-1/2	830	850	850	360	2, F20, R12
	SUH36	U36	16	2-9/16	5-5/16	2	1-1/8	8	10d	4	10d x 1-1/2	930	1065	1160	725	
			16	2-9/16	5-5/16	2	1-1/8	8	16d	4	10d x 1-1/2	1105	1270	1380	725	
	HD36	HU36	14	2-9/16	4-3/4	2	1-1/8	8	16d	4	10d x 1-1/2	1130	1295	1410	730	5, F30, R5
3 x 8	JUS38	-- --	18	2-9/16	6-3/4	2	1	6	16d	4	16d	1290	1485	1615	1355	6, F15, R13
	SUH36	U36	16	2-9/16	5-5/16	2	1-1/8	8	10d	4	10d x 1-1/2	930	1065	1160	725	2, F20, R12
			16	2-9/16	5-5/16	2	1-1/8	8	16d	4	10d x 1-1/2	1105	1270	1380	725	
	HD36	HU36	14	2-9/16	4-3/4	2	1-1/8	8	16d	4	10d x 1-1/2	1130	1295	1410	730	5, F30, R5
	HD38	HU38	14	2-9/16	6-3/4	2	1-1/8	12	16d	4	10d x 1-1/2	1690	1945	2115	730	
3 x 10	JUS310	LUS310	18	2-9/16	9-1/8	2	1	8	16d	6	16d	1800	2070	2250	1980	6, F15, R13
	SUH310	U310	16	2-9/16	8-7/8	2	1-1/8	14	10d	6	10d x 1-1/2	1625	1870	2030	1085	2, F20, R12
			16	2-9/16	8-7/8	2	1-1/8	14	16d	6	10d x 1-1/2	1930	2220	2415	1085	
	HD38	HU38	14	2-9/16	6-3/4	2	1-1/8	12	16d	4	10d x 1-1/2	1690	1945	2115	730	5, F30, R5
	HD310	HU310	14	2-9/16	7-7/16	2-1/2	1-1/8	14	16d	6	10d x 1-1/2	1975	2270	2470	1065	
3 x 12	HDO310IF	HUCQ310-SDS	14	2-9/16	9	3	1-3/16	8	WS3	4	WS15	3340	3380	3380	1470	110
	SUH310	U310	16	2-9/16	8-7/8	2	1-1/8	14	10d	6	10d x 1-1/2	1625	1870	2030	1085	2, F20, R12
			16	2-9/16	8-7/8	2	1-1/8	14	16d	6	10d x 1-1/2	1930	2220	2415	1085	
	HD38	HU38	14	2-9/16	6-3/4	2	1-1/8	12	16d	4	10d x 1-1/2	1690	1945	2115	730	5, F30, R5
	HD310	HU310	14	2-9/16	7-7/16	2-1/2	1-1/8	14	16d	6	10d x 1-1/2	1975	2270	2470	1065	
	HDO310IF	HUCQ310-SDS	14	2-9/16	9	3	1-3/16	8	WS3	4	WS15	3340	3380	3380	1470	110
3 x 14	HD312	HU312	14	2-9/16	9-5/16	2-1/2	1-1/8	16	16d	10	10d x 1-1/2	2255	2595	2820	1065	5, F30, R5
	SUH314	U314	16	2-9/16	10-9/16	2	1-1/8	16	10d	6	10d x 1-1/2	1855	2135	2320	1085	2, F20, R12
			16	2-9/16	10-9/16	2	1-1/8	16	16d	6	10d x 1-1/2	2210	2505	2505	1085	
	HD310	HU310	14	2-9/16	7-7/16	2-1/2	1-1/8	14	16d	6	10d x 1-1/2	1975	2270	2470	1065	5, F30, R5
	HDO310IF	HUCQ310-SDS	14	2-9/16	9	3	1-3/16	8	WS3	4	WS15	3340	3380	3380	1470	110
	HD312	HU312	14	2-9/16	9-5/16	2-1/2	1-1/8	16	16d	10	10d x 1-1/2	2255	2595	2820	1065	5, F30, R5
HD314	HU314	14	2-9/16	11-5/16	2-1/2	1-1/8	20	16d	10	10d x 1-1/2	2820	3245	3525	1065		

- Uplift loads have been increased 60% for wind or seismic loads; no further increase shall be permitted.
- 10d x 1-1/2 nails are 9 gauge (0.148" diameter) by 1-1/2" long.
- Minimum nail embedment shall be 1-1/2" for 10d nails; 1-5/8" for 16d and N16C-GC nails.
- 16d sinkers (9 gauge x 3-1/4" long) may be used at 0.84 of the table load where 16d commons are specified.
- For JUS, HUS, and MUS hangers: Nails must be driven at a 30° to 45° angle through the joist or truss into the header to achieve the table loads.
- WS15 Wood Screws are 1-1/4" x 1-1/2" long and are included with HDQ hangers.
- WS3 Wood Screws are 1-1/4" x 3" long and are included with HDQ hangers.

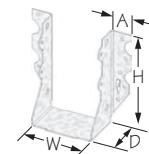

continued on next page

# FACE MOUNT HANGER CHARTS CONTINUED



©Copyright 2011 USP Structural Connectors®

Joist Size	USP Stock No.	Ref. No.	Steel Gauge	Dimensions				Fastener Schedule <sup>2,3,4,6,7</sup>				Allowable Loads (Lbs.)				Code Ref.	
				W	H	D	A	Header		Joist		DF-L / SP					
								Qty	Nail	Qty	Nail	Floor	Roof		Uplift <sup>1</sup>		
				100%	115%	125%	160%										
3 x 16	SUH314	U314	16	2-9/16	10-9/16	2	1-1/8	16	10d	6	10d x 1-1/2	1855	2135	2320	1085	2, F20, R12	
	HD312	HU312	14	2-9/16	10-9/16	2	1-1/8	16	16d	6	10d x 1-1/2	2210	2505	2505	1085		
	HD314	HU314	14	2-9/16	9-5/16	2-1/2	1-1/8	16	16d	10	10d x 1-1/2	2255	2595	2820	1065		
	HD316	HU316	14	2-9/16	11-5/16	2-1/2	1-1/8	20	16d	10	10d x 1-1/2	2820	3245	3525	1065		
(2) 3 x 8	HD38-2	HU38-2	14	5-1/8	6-1/8	2-1/2	1-1/8	14	16d	6	10d	1975	2270	2470	1140	5, F30, R5	
(2) 3 x 10	HD38-2	HU38-2	14	5-1/8	6-1/8	2-1/2	1-1/8	14	16d	6	10d	1975	2270	2470	1140		
(2) 3 x 12	HD310-2	HU310-2	14	5-1/8	8	2-1/2	1-1/8	18	16d	10	10d	2540	2920	3175	1905		
(2) 3 x 14	HD310-2	HU310-2	14	5-1/8	8	2-1/2	1-1/8	18	16d	10	10d	2540	2920	3175	1905		
(3) 2 x 6	JUS26-3	LUS26-3	18	4-5/8	4-1/2	2	1	4	16d	4	16d	1015	1170	1220	1355	6, F5, F15, D7, R13	
	SUH26-3	U26-3	16	4-5/8	5-1/4	2	1	8	10d	2	10d	930	1065	1160	370		2, F20, R12
	HD26-3	HU26-3	14	4-5/8	5-1/4	2	1	8	16d	2	10d	1105	1270	1380	370		
(3) 2 x 8	JUS26-3	LUS26-3	18	4-5/8	4-1/2	2	1	4	16d	4	16d	1015	1170	1220	1355	6, F5, F15, D7, R13	
	JUS28-3	LUS28-3	18	4-5/8	6-3/8	2	1	6	16d	4	16d	1290	1485	1615	1355		
	SUH26-3	U26-3	16	4-5/8	5-1/4	2	1	8	10d	2	10d	930	1065	1160	370		2, F20, R12
	HD26-3	HU26-3	14	4-5/8	5-1/4	2	1	8	16d	2	10d	1105	1270	1380	370		
	HD28-3	---	14	4-5/8	6-3/8	2-1/2	1-1/8	12	16d	6	10d	1690	1945	2095	1140		5, F30, R5
	HD28-3	---	14	4-5/8	6-3/8	2-1/2	1-1/8	12	16d	6	10d	1690	1945	2115	1140		
(3) 2 x 10	JUS28-3	LUS28-3	18	4-5/8	6-3/8	2	1	6	16d	4	16d	1290	1485	1615	1355	6, F5, F15, D7, R13	
	JUS210-3	LUS210-3	18	4-5/8	8-3/8	2	1	8	16d	6	16d	1800	2070	2250	1980		
	SUH210-3	U210-3	16	4-5/8	8-3/8	2	1	14	10d	6	10d	1625	1870	2030	1115		2, F20, R12
	HD210-3	---	14	4-5/8	8-3/8	2	1	14	16d	6	10d	1930	2220	2415	1115		
	HD28-3	---	14	4-5/8	6-3/8	2-1/2	1-1/8	12	16d	6	10d	1690	1945	2115	1140		5, F30, R5
	HD210-3	HU210-3	14	4-5/8	8-1/4	2-1/2	1-1/8	18	16d	10	10d	2540	2920	3175	1905		
(3) 2 x 12	JUS210-3	LUS210-3	18	4-5/8	8-3/8	2	1	8	16d	6	16d	1800	2070	2250	1980	6, F5, F15, D7, R13	
	SUH210-3	U210-3	16	4-5/8	8-3/8	2	1	14	10d	6	10d	1625	1870	2030	1115		2, F20, R12
	HD210-3	HU210-3	14	4-5/8	8-3/8	2	1	14	16d	6	10d	1930	2220	2415	1115		
	HD210-3	HU210-3	14	4-5/8	8-1/4	2-1/2	1-1/8	18	16d	10	10d	2540	2920	3175	1905		5, F30, R5
	HDQ210-3IF	HUCQ210-3-SDS	14	4-5/8	9	3	1-1/2	12	WS3	6	WS3	5015	5590	5590	2975		
	HD212-3	HU212-3	14	4-5/8	10-1/4	2-1/2	1-1/8	22	16d	10	10d	3100	3565	3880	1905		
(3) 2 x 14	JUS210-3	LUS210-3	18	4-5/8	8-3/8	2	1	8	16d	6	16d	1800	2070	2250	1980	6, F5, F15, D7, R13	
	SUH210-3	U210-3	16	4-5/8	8-3/8	2	1	14	10d	6	10d	1625	1870	2030	1115		2, F20, R12
	HD210-3	HU210-3	14	4-5/8	8-3/8	2	1	14	16d	6	10d	1930	2220	2415	1115		
	HDQ210-3IF	HUCQ210-3-SDS	14	4-5/8	8-1/4	2-1/2	1-1/8	18	16d	10	10d	2540	2920	3175	1905		5, F30, R5
	HD212-3	HU212-3	14	4-5/8	9	3	1-1/2	12	WS3	6	WS3	5015	5590	5590	2975		
	HD212-3	HU212-3	14	4-5/8	10-1/4	2-1/2	1-1/8	22	16d	10	10d	3100	3565	3880	1905		
	HD214-3	HU214-3	14	4-5/8	12-1/4	2-1/2	1-1/8	24	16d	10	10d	3385	3890	4230	1905		5, F30, R5
	HD214-3	HU214-3	14	4-5/8	12-1/4	2-1/2	1-1/8	24	16d	10	10d	3385	3890	4230	1905		
(3) 2 x 16	HD216-3	HU216-3	14	4-5/8	14-1/4	2-1/2	1-1/8	26	16d	12	10d	3665	4215	4570	2285		
	(4) 2 x 10	HD210-4	HU210-4	14	6-1/8	9	3-1/4	2	24	16d	6	10d	3385	3890	4230	1140	5, R5
	(4) 2 x 12	HD210-4	HU210-4	14	6-1/8	9	3-1/4	2	24	16d	6	10d	3385	3890	4230	1140	
(4) 2 x 14	HD210-4	HU210-4	14	6-1/8	9	3-1/4	2	24	16d	6	10d	3385	3890	4230	1140		
4 x 4	JUS44	LUS44	18	3-5/8	3-1/4	2	1	4	16d	2	16d	780	900	965	325	6, F5, R13	
	SUH44	U44	16	3-9/16	2-7/8	2	1-1/8	6	10d	2	10d	695	800	870	370		2, F20, R12
	HD44	HU44	14	3-9/16	2-7/8	2	1-1/8	6	16d	2	10d	830	950	1035	370		
4 x 6	JUS46	LUS46	18	3-5/8	5	2	1	4	16d	4	16d	1015	1170	1220	1355	6, F5, F15, D7, R13	
	SUH44	U44	16	3-9/16	2-7/8	2	1-1/8	6	10d	2	10d	695	800	870	370		2, F20, R12
	SUH46	U46	16	3-9/16	2-7/8	2	1-1/8	6	16d	2	10d	830	950	1035	370		
	SUH46	U46	16	3-9/16	4-13/16	2	1-1/8	8	10d	4	10d	930	1065	1160	740		6, F18, F15, D2, R13
	SUH46	U46	16	3-9/16	4-13/16	2	1-1/8	8	16d	4	10d	1105	1270	1380	740		
	HD46	HU46	14	3-9/16	4-15/16	2-1/2	1-1/8	12	16d	6	10d	1690	1945	2095	1140		

Hangers

continued on next page

Joist Size	USP Stock No.	Ref. No.	Steel Gauge	Dimensions				Fastener Schedule <sup>2,3,4,5,6</sup>				Allowable Loads (Lbs.)				Code Ref.
				W	H	D	A	Header		Joist		DF-L / SP				
								Qty	Nail	Qty	Nail	Floor	Roof		Uplift <sup>1</sup>	
				100%	115%	125%	160%									
4 x 8	JUS46	LUS46	18	3-5/8	5	2	1	4	16d	4	16d	1015	1170	1220	1355	6, F5,
	JUS48	LUS48	18	3-5/8	6-7/8	2	1	6	16d	4	16d	1290	1485	1615	1355	F15, D7, R13
	SUH46	U46	16	3-9/16	4-13/16	2	1-1/8	8	10d	4	10d	930	1065	1160	740	2, F20, R12
			16	3-9/16	4-13/16	2	1-1/8	8	16d	4	10d	1105	1270	1380	740	
	HUS46	HUS46	14	3-5/8	5	2	1	4	16d	4	16d	1030	1185	1290	1115	6, F18,
	HUS48	HUS48	14	3-5/8	7	2	1	6	16d	6	16d	1550	1780	1935	1810	F15, D2, R13
	HD46	HU46	14	3-9/16	4-15/16	2-1/2	1-1/8	12	16d	6	10d	1690	1945	2095	1140	5, F30, R5
HD48	HU48	14	3-9/16	6-7/8	2-1/2	1-1/8	14	16d	6	10d	1975	2270	2470	1140		
4 x 10	JUS48	LUS48	18	3-5/8	6-7/8	2	1	6	16d	4	16d	1290	1485	1615	1355	6, F5,
	JUS410	LUS410	18	3-5/8	8-7/8	2	1	8	16d	6	16d	1800	2070	2250	1980	F15, D7, R13
	SUH410	U410	16	3-9/16	8-3/8	2	1-1/8	14	10d	6	10d	1625	1870	2030	1115	2, F20, R12
			16	3-9/16	8-3/8	2	1-1/8	14	16d	6	10d	1930	2220	2415	1115	
	HUS48	HUS48	14	3-5/8	7	2	1	6	16d	6	16d	1550	1780	1935	1810	6, F18, F15, D2, R13
	HD48	HU48	14	3-9/16	6-7/8	2-1/2	1-1/8	14	16d	6	10d	1975	2270	2470	1140	5, F30, R5
	HUS410	HUS410	14	3-5/8	8-7/8	2	1	8	16d	8	16d	2065	2375	2580	2210	6, F18, F15, D2, R13
	HD410	HU410	14	3-9/16	8-13/16	2-1/2	1-1/8	18	16d	10	10d	2540	2920	3175	1905	5, F30, R5
HDO410IF	HUCQ410-SDS	14	3-9/16	9	3	1-1/2	12	WS3	6	WS3	5015	5590	5590	2975	110	
4 x 12	JUS410	LUS410	18	3-5/8	8-7/8	2	1	8	16d	6	16d	1800	2070	2250	1980	6, F5, F15, D7, R13
	SUH410	U410	16	3-9/16	8-3/8	2	1-1/8	14	10d	6	10d	1625	1870	2030	1115	2, F20, R12
			16	3-9/16	8-3/8	2	1-1/8	14	16d	6	10d	1930	2220	2415	1115	
	HD48	HU48	14	3-9/16	6-7/8	2-1/2	1-1/8	14	16d	6	10d	1975	2270	2470	1140	5, F30, R5
	HUS410	HUS410	14	3-5/8	8-7/8	2	1	8	16d	8	16d	2065	2375	2580	2210	6, F18, F15, D2, R13
	HD410	HU410	14	3-9/16	8-13/16	2-1/2	1-1/8	18	16d	10	10d	2540	2920	3175	1905	5, F30, R5
	HDO410IF	HUCQ410-SDS	14	3-9/16	9	3	1-1/2	12	WS3	6	WS3	5015	5590	5590	2975	110
	HUS412	HUS412	14	3-5/8	10-7/8	2	1	10	16d	10	16d	2580	2965	3225	3060	6, F18, F15, D2, R13
HDO412IF	HUCQ412-SDS	14	3-9/16	11	3	1-1/2	14	WS3	6	WS3	5590	5590	5590	2975	110	
HD412	HU412	14	3-9/16	10-13/16	2-1/2	1-1/8	22	16d	10	10d	3100	3565	3880	1905	5, F30, R5	
4 x 14	JUS414	LUS414	18	3-5/8	12-7/8	2	1	12	16d	6	16d	2345	2700	2935	1980	6, F15, R13
	SUH414	U414	16	3-9/16	10-1/16	2	1-1/8	16	10d	6	10d	1855	2135	2320	1115	2, F20, R12
			16	3-9/16	10-1/16	2	1-1/8	16	16d	6	10d	2210	2540	2760	1115	
	HD410	HU410	14	3-9/16	8-13/16	2-1/2	1-1/8	18	16d	10	10d	2540	2920	3175	1905	5, F30, R5
	HDO410IF	HUCQ410-SDS	14	3-9/16	9	3	1-1/2	12	WS3	6	WS3	5015	5590	5590	2975	110
	HUS412	HUS412	14	3-5/8	10-7/8	2	1	10	16d	10	16d	2580	2965	3225	3060	6, F18, F15, D2, R13
	HDO412IF	HUCQ412-SDS	14	3-9/16	11	3	1-1/2	14	WS3	6	WS3	5590	5590	5590	2975	110
	HD412	HU412	14	3-9/16	10-13/16	2-1/2	1-1/8	22	16d	10	10d	3100	3565	3880	1905	5, F30, R5
HD414	HU414	14	3-9/16	12-13/16	2-1/2	1-1/8	24	16d	10	10d	3385	3890	4230	1905	5, F30, R5	
4 x 16	JUS414	LUS414	18	3-5/8	12-7/8	2	1	12	16d	6	16d	2345	2700	2935	1980	6, F15, R13
	SUH414	U414	16	3-9/16	10-1/16	2	1-1/8	16	10d	6	10d	1855	2135	2320	1115	2, F20, R12
			16	3-9/16	10-1/16	2	1-1/8	16	16d	6	10d	2210	2540	2760	1115	
	HD412	HU412	14	3-9/16	10-13/16	2-1/2	1-1/8	22	16d	10	10d	3100	3565	3880	1905	5, F30, R5
	HDO412IF	HUCQ412-SDS	14	3-9/16	11	3	1-1/2	14	WS3	6	WS3	5590	5590	5590	2975	110
	HD414	HU414	14	3-9/16	12-13/16	2-1/2	1-1/8	24	16d	10	10d	3385	3890	4230	1905	5, F30, R5
HD416	HU416	14	3-9/16	14-13/16	2-1/2	1-1/8	26	16d	12	10d	3665	4215	4570	2285	5, F30, R5	
4 x 18	HD414	HU414	14	3-9/16	12-13/16	2-1/2	1-1/8	24	16d	10	10d	3385	3890	4230	1905	5, F30, R5
	HD416	HU416	14	3-9/16	14-13/16	2-1/2	1-1/8	26	16d	12	10d	3665	4215	4570	2285	5, F30, R5
	HD418	---	14	3-9/16	16-1/2	2-1/2	1-1/4	28	16d	8	10d	3950	4540	4570	1425	

1) Uplift loads have been increased 60% for wind or seismic loads; no further increase shall be permitted.

2) 10d x 1-1/2 nails are 9 gauge (0.148" diameter) by 1-1/2" long.

3) Minimum nail embedment shall be 1-1/2" for 10d nails and 1-5/8" for 16d nails.

4) 16d sinkers (9 gauge x 3-1/4" long) may be used at 0.84 of the table load where 16d commons are specified.

5) WS15 Wood Screws are 1-1/4" x 1-1/2" long and are included with HDQ hangers.

6) WS3 Wood Screws are 1-1/4" x 3" long and are included with HDQ hangers.

# FACE MOUNT HANGER CHARTS CONTINUED



©Copyright 2011 USP Structural Connectors®

Joist Size	USP Stock No.	Ref. No.	Steel Gauge	Dimensions				Fastener Schedule <sup>2,3,4</sup>				Allowable Loads (Lbs.)				Code Ref.
				W	H	D	A	Header		Joist		DF-L / SP				
								Qty	Nail	Qty	Nail	Floor	Roof		Uplift <sup>1</sup>	
100%	115%	125%	160%													
6 x 6	SUH66	U66	16	5-1/2	5	2	1	8	10d	4	10d	930	1065	1160	740	2, F20, R12
			16	5-1/2	5	2	1	8	16d	4	10d	1105	1270	1380	740	
6 x 8	SUH66	U66	14	5-1/2	3-15/16	2-1/2	1-1/8	12	16d	6	10d	1690	1945	2095	1140	5, F30, R5
			16	5-1/2	5	2	1	8	16d	4	10d	930	1065	1160	740	
	HD66	HU66	14	5-1/2	3-15/16	2-1/2	1-1/8	12	16d	6	10d	1690	1945	2095	1140	5, F30, R5
			14	5-1/2	5-15/16	2-1/2	1-1/8	14	16d	6	10d	1975	2270	2470	1140	
6 x 10	SUH610	U610	16	5-1/2	9	2	1	14	10d	6	10d	1625	1870	2030	1115	2, F20, R12
			16	5-1/2	9	2	1	14	16d	6	10d	1930	2220	2415	1115	
	HD610	HU610	14	5-1/2	5-15/16	2-1/2	1-1/8	14	16d	6	10d	1975	2220	2470	1140	5, F30, R5
			14	5-1/2	7-13/16	2-1/2	1-1/8	18	16d	10	10d	2540	2920	3175	1905	
6 x 12	SUH610	U610	16	5-1/2	9	2	1	14	10d	6	10d	1625	1870	2030	1115	2, F20, R12
			16	5-1/2	9	2	1	14	16d	6	10d	1930	2220	2415	1115	
	HD610	HU610	14	5-1/2	7-13/16	2-1/2	1-1/8	18	16d	10	10d	2540	2920	3175	1905	5, F30, R5
			14	5-1/2	9	3	1-1/2	12	WS3	6	WS3	5015	5590	5590	2975	
6 x 14	SUH610	U610	16	5-1/2	9	2	1	14	10d	6	10d	1625	1870	2030	1115	2, F20, R12
			16	5-1/2	9	2	1	14	16d	6	10d	1930	2220	2415	1115	
	HD610	HU610	14	5-1/2	7-13/16	2-1/2	1-1/8	18	16d	10	10d	2540	2920	3175	1905	5, F30, R5
			14	5-1/2	9-13/16	2-1/2	1-1/8	22	16d	10	10d	3100	3565	3880	1905	
6 x 16	SUH610	U610	16	5-1/2	9	2	1	14	10d	6	10d	1625	1870	2030	1115	2, F20, R12
			16	5-1/2	9	2	1	14	16d	6	10d	1930	2220	2415	1115	
	HD610	HU610	14	5-1/2	7-13/16	2-1/2	1-1/8	18	16d	10	10d	2540	2920	3175	1905	5, F30, R5
			14	5-1/2	9-13/16	2-1/2	1-1/8	22	16d	10	10d	3100	3565	3880	1905	
6 x 18	SUH610	U610	16	5-1/2	9	2	1	14	10d	6	10d	1625	1870	2030	1115	2, F20, R12
			16	5-1/2	9	2	1	14	16d	6	10d	1930	2220	2415	1115	
	HD610	HU610	14	5-1/2	7-13/16	2-1/2	1-1/8	18	16d	10	10d	2540	2920	3175	1905	5, F30, R5
			14	5-1/2	9-13/16	2-1/2	1-1/8	22	16d	10	10d	3100	3565	3880	1905	
8 x 6	SUH86	---	14	7-1/2	5-1/8	2-1/2	1-1/2	10	16d	4	16d	1410	1620	1740	900	5, R5
			14	7-1/2	5-1/8	2-1/2	1-1/2	10	16d	4	16d	1410	1620	1740	900	
	HD86	---	14	7-1/2	5-1/8	2-1/2	1-1/2	10	16d	4	16d	1410	1620	1740	900	5, R5
			14	7-1/2	5-1/8	2-1/2	1-1/2	10	16d	4	16d	1410	1620	1740	900	
8 x 8	SUH88	HU88	14	7-1/2	6-5/8	2-1/2	1-1/2	14	16d	6	16d	1975	2270	2470	1355	5, R5
			14	7-1/2	6-5/8	2-1/2	1-1/2	14	16d	6	16d	1975	2270	2470	1355	
	HD88	HU88	14	7-1/2	6-5/8	2-1/2	1-1/2	14	16d	6	16d	1975	2270	2470	1355	5, R5
			14	7-1/2	6-5/8	2-1/2	1-1/2	14	16d	6	16d	1975	2270	2470	1355	
8 x 10	SUH810	HU810	14	7-1/2	8-3/8	2-1/2	1-1/2	18	16d	8	16d	2540	2920	3175	1805	5, R5
			14	7-1/2	8-3/8	2-1/2	1-1/2	18	16d	8	16d	2540	2920	3175	1805	
	HD810	HU810	14	7-1/2	8-3/8	2-1/2	1-1/2	18	16d	8	16d	2540	2920	3175	1805	5, R5
			14	7-1/2	8-3/8	2-1/2	1-1/2	18	16d	8	16d	2540	2920	3175	1805	
8 x 12	SUH812	HU812	14	7-1/2	10-1/8	2-1/2	1-1/2	22	16d	8	16d	3100	3565	3880	1805	5, R5
			14	7-1/2	10-1/8	2-1/2	1-1/2	22	16d	8	16d	3100	3565	3880	1805	
	HD812	HU812	14	7-1/2	10-1/8	2-1/2	1-1/2	22	16d	8	16d	3100	3565	3880	1805	5, R5
			14	7-1/2	10-1/8	2-1/2	1-1/2	22	16d	8	16d	3100	3565	3880	1805	
8 x 14	SUH814	HU814	14	7-1/2	11-7/8	2-1/2	1-1/2	24	16d	12	16d	3385	3890	4230	2705	5, R5
			14	7-1/2	11-7/8	2-1/2	1-1/2	24	16d	12	16d	3385	3890	4230	2705	
	HD814	HU814	14	7-1/2	11-7/8	2-1/2	1-1/2	24	16d	12	16d	3385	3890	4230	2705	5, R5
			14	7-1/2	11-7/8	2-1/2	1-1/2	24	16d	12	16d	3385	3890	4230	2705	
8 x 16	SUH816	HU816	14	7-1/2	13-5/8	2-1/2	1-1/2	26	16d	12	16d	3665	4215	4465	2705	5, R5
			14	7-1/2	13-5/8	2-1/2	1-1/2	26	16d	12	16d	3665	4215	4465	2705	
	HD816	HU816	14	7-1/2	13-5/8	2-1/2	1-1/2	26	16d	12	16d	3665	4215	4465	2705	5, R5
			14	7-1/2	13-5/8	2-1/2	1-1/2	26	16d	12	16d	3665	4215	4465	2705	
Rough Lumber Sizes																
2 x 4	SUH24R	LU24R-18, U24R	16	2	3-1/16	2	1-1/8	4	10d	2	10d x 1-1/2	465	535	580	360	2, F20, R12
			16	2	3-1/16	2	1-1/8	4	16d	2	10d x 1-1/2	550	635	690	360	
2 x 6 - 8	SUH26R	LU26R-18, U26R	16	2	4-15/16	2	1-3/16	6	10d	4	10d x 1-1/2	695	800	870	725	2, F20, R12
			16	2	4-15/16	2	1-3/16	6	16d	4	10d x 1-1/2	830	950	1035	725	
2 x 8 - 10	SUH28R	LU28R-18	16	2	6-7/16	2	1-1/8	8	10d	6	10d x 1-1/2	930	1065	1160	800	130
			16	2	6-7/16	2	1-1/8	8	16d	6	10d x 1-1/2	1105	1270	1380	800	
2 x 10 - 12 - 14	SUH210R	LU210R-18, U210R	16	2	7-13/16	2	1-1/8	10	10d	6	10d x 1-1/2	1160	1335	1450	1085	130
			16	2	7-13/16	2	1-1/8	10	16d	6	10d x 1-1/2	1380	1585	1725	1085	
2 x 14 - 16	SUH214R	---	16	2	9-13/16	2	1-1/8	12	10d	6	10d x 1-1/2	1390	1600	1740	1085	130
			16	2	9-13/16	2	1-1/8	12	16d	6	10d x 1-1/2	1655	1905	2070	1085	
4 x 6	SUH44R	U44R	16	4	2-11/16	2	1-1/8	6	10d	2	16d	695	800	870	440	2, F20, R12
			16	4	2-11/16	2	1-1/8	6	16d	2	16d	830	950	1035	440	
4 x 8	SUH46R	U46R	16	4	4-11/16	2	1-1/8	8	10d	4	16d	930	1065	1160	885	2, F20, R12
			16	4	4-11/16	2	1-1/8	8	16d	4	16d	1105	1270	1380	885	
4 x 10	SUH410R	U410R	16	4	8-3/16	2	2	14	10d	6	16d	1625	1870	2030	1325	2, F20, R12
			16	4	8-3/16	2	2	14	16d	6	16d	1930	2220	2415	1325	
6 x 8	SUH66R	U66R	16	6	5	2	1	8	10d	4	16d	930	1065	1160	885	2, F20, R12
			16	6	5	2	1	8	16d	4	16d	1105	1270	1380	885	
6 x 10	SUH610R	U610R	16	6	9	2	1	14	10d	6	16d	1625	1870	2030	1325	2, F20, R12
			16	6	9	2	1	14	16d	6	16d	1930	2220	2415	1325	
Glulam Sizes																
3-1/8 x 10-1/2 - 19-1/2	HD32105	HU3.25/10.5	14	3-1/4	9-15/16	2-1/2	1-1/8	22	16d	10	10d	3100	3565	3880	1905	5, F30, R5
3-1/8 x 12 - 21	HD3212	HU3.25/12	14	3-1/4	11-7/8	2-1/2	1-1/8	24	16d	10	10d	3385	3890	4230	1905	
5-1/8 x 10-1/2 - 19-1/2	HD5112	HU5.125/12	14	5-1/4	9-15/16	2-1/2	1-1/8	22	16d	10	10d	3100	3565	3880	1905	
5-1/8 x 14-1/2 - 21	HD51135	HU5.125/13.5	14	5-1/4	12-15/16	2-1/2	1-1/8	26	16d	12	10d	3665	4215	4570	2285	

- Uplift loads have been increased 60% for wind or seismic loads; no further increase shall be permitted.
- 10d x 1-1/2 nails are 9 gauge (0.148" diameter) by 1-1/2" long.
- Minimum nail embedment shall be 1-1/2" for 10d nails and 1-5/8" for 16d nails.
- 16d sinkers (9 gauge x 3-1/4" long) may be used at 0.84 of the table load where 16d commons are specified.
- WS15 Wood Screws are 1-1/4" x 1-1/2" long and are included with HDQ hangers.
- WS3 Wood Screws are 1-1/4" x 3" long and are included with HDQ hangers.

Primarily used to hang joists or headers in medium load conditions. These hangers provide higher load values with less nailing.

**Materials:** 12 gauge

**Finish:** G90 galvanizing

**Options:** All nominal lumber sizes are available for rough/full size lumber. See Specialty Options Chart.

**Codes:** ESR-1781, FL13285, L.A. City RR 25843

**Installation:**

- Use all specified fasteners. See Product Notes, page 11.
- Check top flange dimensions to ensure compatibility with header widths.

**• Do not use for welded or nailer applications. Reference Specialty Options chart below for hanger options.**

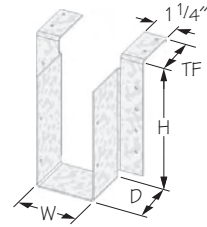

**HDO28-2**

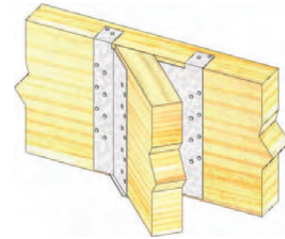

**Typical HDO skewed option installation**

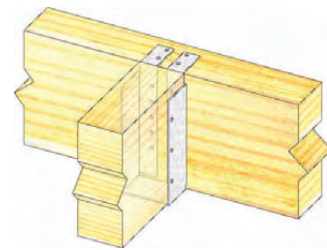

**Typical HDO410IF inverted flange installation**

© Copyright 2011 USP Structural Connectors®

**Specialty Options Chart** – refer to Specialty Options pages 194-195 for additional details.

Option	Skewed <sup>1,3</sup>	Sloped Seat <sup>2,3</sup>	Sloped / Skewed <sup>1,2,3</sup>	Inverted Flange
Range	1' to 67-1/2' when width is 1-3/4" or less. 1' to 50' on all others.	1' to 45'	See Sloped Seat and Skewed	Not available in widths less than 3-1/8"
Allowable Loads	100% of table load. 75% of uplift load on skews greater than 15'.	100% of table load	80% of table load. 75% of uplift load on skews greater than 15'.	100% of table load. 65% of table load when nailing into the support members end grain.
Ordering	Add SK, angle required, and right (R) or left (L), to product number. Ex. HDO210-SK45R	Add SL, slope required, and up (U) or down (D), to product number. Ex. HDO210-SL30D	See Sloped Seat and Skewed. Ex. HDO210-SK45RSL30D	Add IF to product number. Ex. HDO610IF

1) Skewed hangers with skews greater than 15° may have all joist nailing on outside flange.  
 2) Sloped or sloped / skewed hangers with slopes greater than 15° may have additional joist nails.  
 3) All sloped, skewed, or combinations require bevel cut on joist in all applications and web stiffeners with I-joists.

**SW** – Light-duty hanger.

**SWH** – Medium-duty hanger.

**KHW** – Heavy-duty hanger installs with NA20D nails for higher load capacities.

**Materials:** SW top flange - 12 gauge;  
stirrup - 12 gauge;  
SWH top flange - 7 gauge;  
stirrup - 12 gauge;  
KHW top flange - 3 gauge;  
stirrup - 10 gauge.

**Finish:** USP primer

**Options:** All nominal lumber sizes are available for rough/full size lumber. See Specialty Options below.

**Codes:** ESR-2104, FL820,  
L.A. City RR 25745

**Installation:**

- Use all specified fasteners. See Product Notes, page 11.
- NA20D nails are supplied with KHW hangers.
- For welded installations see page 198.
- **KHW models are not recommended for use with LVL, PSL, or LSL members.**

**Nailer Installation Chart** – chart represents maximum allowable loads for hangers used on wood nailers. Reference page 115.

USP Stock No.	Nailer Size	Fastener Schedule <sup>1,2,3</sup>		Allowable Loads (Lbs.) <sup>4</sup>	
		Header	Joist	DF-L / SP	S-P-F
SW	2X	(2) 10d x 1-1/2	(2) 10d x 1-1/2	1635	1115
SWH	2X	(2) 10d x 1-1/2	(2) 10d	2600	1770
	3X	(2) 16d x 2-1/2	(2) 10d	3350	2280
KHW	3X	(4) 16d x 2-1/2	(2) 10d	5180	3525

- 1) 10d x 1-1/2 nails are 9 gauge (0.148" diameter) by 1-1/2" long.
- 2) 16d x 2-1/2 nails are 8 gauge (0.162" diameter) by 2-1/2" long.
- 3) Minimum nail embedment shall be 1-1/2" for 10d nails.
- 4) Listed loads shall not be increased.

**Specialty Options Chart** – refer to Specialty Options pages 194, 196 to 197 for additional details.

Option	Skewed <sup>1</sup>	Sloped Seat <sup>2</sup>	Sloped / Skewed <sup>1,2</sup>	Sloped Top Flange <sup>3</sup>	Top Flange Offset		Saddle	Ridge
Range	1° to 84°	1° to 45°	See Sloped Seat and Skewed	0° to 35°	-- --		-- --	0° to 45°
Allowable Loads	100% of table load	100% of table load	100% of table load	Reduce allowable table loads using straight-line interpolation	Hanger Width 3-1/2" or less 3-9/16" to 5-1/2" 5-9/16" to 7-1/2"	% of table load: 60% 75% 85%	100% of table load per side	100% of table load
Ordering	Add SK, angle required, and right (R) or left (L), to product number. Ex. SW212-SK45R	Add SL, slope required, and up (U) or down (D), to product number. Ex. SW212-SL30D	See Sloped Seat and Skewed. Ex. SW212-SK45RSL30D	Add SF angle required, and right (R) or left (L), to product number. Ex. SW212-SF30L	Add OS, and right (R) or left (L), to product number. Ex. SW212-OSL		Add SA, and saddle width required to product number. Ex. SW212-SA=5-1/2"	Add DA, angle required to product number. Ex. SW212-DA30

- 1) Skewed hangers with skews greater than 15° may have all joist nailing on outside flange.
- 2) Sloped or sloped / skewed hangers with slopes greater than 15° may have additional joist nails.
- 3) Sloped top flanges with greater than 15° may have additional header nails.

## LIGHT GAUGE PURLIN HANGERS – HL SERIES

These top mount hangers are designed for supporting floor joists or 2x purlins. The top mount style allows builders to drop in joists or purlins quickly.

**Materials:** 18 gauge

**Finish:** G90 galvanizing

**Codes:** ESR-1280, FL11664, LA City RR 25749

**Installation:**

- Use all specified fasteners. See Product Notes, page 11.

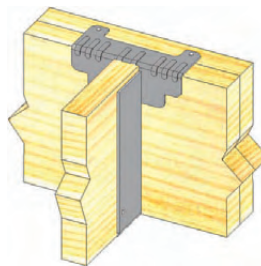

Typical **SW210** installation

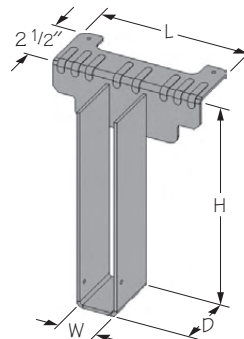

**SW210**

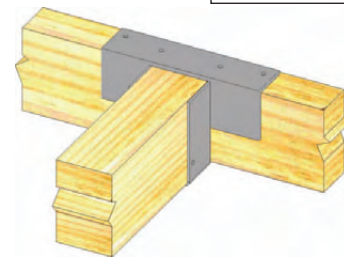

Typical **KHW46** installation

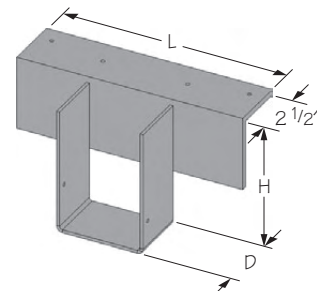

**KHW46**

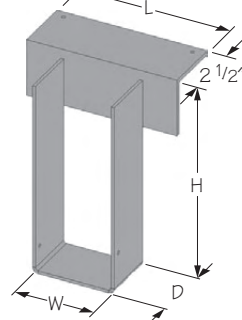

**SWH410**

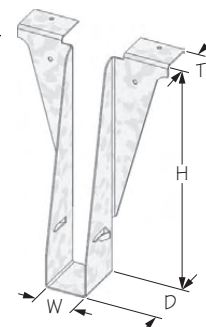

**HL210**

Hangers

Beam/ Joist Size	USP Stock No.	Ref. No.	Steel Gauge	Dimensions					Fastener Schedule <sup>3,4</sup>					Allowable Loads (Lbs.) <sup>5</sup>				Code Ref.
				W	H	D	L	TF	Header		Joist			DF-L / SP				
									Qty		Type	Qty	Type	Floor	Roof	Uplift <sup>1,2</sup>		
									Top	Face							100%	
2 x 4	HDO24	HU24TF	12	1-9/16	3-7/16	2-1/4	---	2-1/2	4	2	16d	2	10d x 1-1/2	2170	2170	2170	315	5, F30, R5
2 x 6	HL26	JB26, LB26	18	1-9/16	5-3/8	1-1/2	---	1-5/16	2	4	16d	2	prongs	1270	1270	1270	---	2, F20, R12
	SW26	W26	12	1-9/16	5-3/8	2-1/2	6-1/2	2-1/2	2	---	10d	2	10d x 1-1/2	2315	2315	2315	---	8, F14, R9
	HDO26	HU26TF	12	1-9/16	5-3/8	2-1/4	---	2-1/2	4	6	16d	4	10d x 1-1/2	2590	2615	2615	770	5, F30, R5
2 x 8	HL28	JB28, LB28	18	1-9/16	7-5/16	1-3/4	---	1-5/16	2	4	16d	2	prongs	1590	1590	1590	---	2, F20, R12
	SW28	W28	12	1-9/16	7-1/8	2-1/2	6-1/2	2-1/2	2	---	10d	2	10d x 1-1/2	2315	2315	2315	---	8, F14, R9
	HDO28	HU28TF	12	1-9/16	7-1/8	2-1/4	---	2-1/2	4	6	16d	4	10d x 1-1/2	2590	2660	2710	755	5, F30, R5
2 x 10	HL210	JB210, LB210	18	1-9/16	9-5/16	2	---	1-5/16	2	4	16d	2	prongs	1590	1590	1590	---	2, F20, R12
	SW210	W210	12	1-9/16	9-1/8	2-1/2	6-1/2	2-1/2	2	---	10d	2	10d x 1-1/2	2315	2315	2315	---	8, F14, R9
	HDO210	HU210TF	12	1-9/16	9-1/8	2-1/4	---	2-1/2	4	8	16d	4	10d x 1-1/2	2590	2660	2710	725	5, F30, R5
2 x 12	HL212	JB212, LB212	18	1-9/16	11-1/4	2-1/8	---	1-5/16	2	4	16d	2	prongs	1590	1590	1590	---	2, F20, R12
	SW212	W212	12	1-9/16	11-1/8	2-1/2	6-1/2	2-1/2	2	---	10d	2	10d x 1-1/2	2315	2315	2315	---	8, F14, R9
	HDO212	HU212TF	12	1-9/16	11	2-1/4	---	2-1/2	4	10	16d	6	10d x 1-1/2	2355	2355	2355	1150	5, F30, R5
2 x 14	HL214	JB214, LB214	18	1-9/16	13-1/8	2	---	2-1/2	2	6	16d	2	10d x 1-1/2	1590	1590	1590	360	2, F20, R12
	SW214	W214	12	1-9/16	13-1/8	2-1/2	6-1/2	2-1/2	2	---	10d	2	10d x 1-1/2	2315	2315	2315	---	8, F14, R9
	HDO214	HU214TF	12	1-9/16	13	2-1/4	---	2-1/2	4	12	16d	6	10d x 1-1/2	2830	2935	3010	1050	5, F30, R5
2 x 16	SW216	W216	12	1-9/16	15-1/8	2-1/2	6-1/2	2-1/2	2	---	10d	2	10d x 1-1/2	2315	2315	2315	---	8, F14, R9
	HDO216	HU216TF, LB216	12	1-9/16	15	2-1/4	---	2-1/2	4	14	16d	8	10d x 1-1/2	3070	3215	3310	1535	5, F30, R5
3 x 4	HDO34	HU34TF	12	2-9/16	3-7/16	2-1/2	---	2-1/2	4	4	16d	2	10d x 1-1/2	2665	2665	2665	315	5, F30, R5
3 x 6	SW36	W36	12	2-9/16	5-3/8	2-1/2	6-1/2	2-1/2	2	---	10d	2	10d x 1-1/2	2315	2315	2315	---	8, F14, R9
	HDO36	HU36TF	12	2-9/16	5-3/8	2-1/2	---	2-1/2	4	6	16d	4	10d x 1-1/2	3010	3010	3010	770	5, F30, R5
3 x 8	SW38	W38	12	2-9/16	7-1/8	2-1/2	6-1/2	2-1/2	2	---	10d	2	10d x 1-1/2	2315	2315	2315	---	8, F14, R9
	HDO38	B38, HU38TF	12	2-9/16	7-1/8	2-1/2	---	2-1/2	4	8	16d	4	10d x 1-1/2	3605	3605	3605	755	5, F30, R5
3 x 10	SW310	W310	12	2-9/16	9-1/8	2-1/2	6-1/2	2-1/2	2	---	10d	2	10d x 1-1/2	2315	2315	2315	---	8, F14, R9
	HDO310	B310, HU310TF	12	2-9/16	9-1/8	2-1/2	---	2-1/2	4	10	16d	6	10d x 1-1/2	4165	4165	4165	1150	5, F30, R5
3 x 12	SWH312	WNP312	7/12	2-9/16	11-1/8	2-1/2	7	2-1/2	2	---	10d	2	10d x 1-1/2	3305	3305	3305	---	8, F14, R9
	HDO312	B312, HU312TF	12	2-9/16	11	2-1/2	---	2-1/2	4	12	16d	6	10d x 1-1/2	4475	4475	4475	1150	5, F30, R5
3 x 14	SWH314	WNP314	7/12	2-9/16	13-1/8	2-1/2	7	2-1/2	2	---	10d	2	10d x 1-1/2	3305	3305	3305	---	8, F14, R9
	HDO314	B314, HU314TF	12	2-9/16	13	2-1/2	---	2-1/2	4	14	16d	8	10d x 1-1/2	4475	4475	4475	1315	5, F30, R5
3 x 16	SWH316	WNP316	7/12	2-9/16	15-1/8	2-1/2	7	2-1/2	2	---	10d	2	10d x 1-1/2	3305	3305	3305	---	8, F14, R9
	HDO316	B316, HU316TF	12	2-9/16	15	2-1/2	---	2-1/2	4	16	16d	8	10d x 1-1/2	4865	5010	5105	1535	5, F30, R5
(2) 2 x 4	HDO24-2	HU24-2TF	12	3-1/8	3-7/16	2-1/4	---	2-1/2	4	4	16d	2	10d	2445	2445	2445	405	5, F30, R5
(2) 2 x 6	SWH26-2	WNP26-2	7/12	3-1/8	5-3/8	2-1/2	7	2-1/2	2	---	10d	2	10d	3305	3305	3305	---	8, F14, R9
	HDO26-2	HU26-2TF, HUS26-2TF	12	3-1/8	5-3/8	2-1/4	---	2-1/2	4	6	16d	4	10d	3050	3050	3050	815	5, F30, R5
(2) 2 x 8	SWH28-2	WNP28-2	7/12	3-1/8	7-1/8	2-1/2	7	2-1/2	2	---	10d	2	10d	3305	3305	3305	---	8, F14, R9
	HDO28-2	HU28-2TF, HUS28-2TF	12	3-1/8	7-1/8	2-1/4	---	2-1/2	4	8	16d	4	10d	3825	3825	3825	815	5, F30, R5
(2) 2 x 10	SWH210-2	WNP210-2	7/12	3-1/8	9-1/8	2-1/2	7	2-1/2	2	---	10d	2	10d	3305	3305	3305	---	8, F14, R9
	HDO210-2	HU210-2TF, HUS210-2TF	12	3-1/8	9-1/8	2-1/2	---	2-1/2	4	10	16d	6	10d	4565	4565	4565	1220	5, F30, R5

1) Uplift Loads have been increased 60% for wind or seismic loads; no further increase shall be permitted.  
 2) HL, KHW, SW, and SWH products do not provide uplift resistance, except for the HL214.  
 3) Minimum nail embedment shall be 1-1/2" for 10d nails, 1-5/8" for 16d nails, and 2" for NA20D nails.  
 4) 10d x 1-1/2 nails are 9 gauge (0.148" diameter) by 1-1/2" long.  
 5) NA20D nails are 6 gauge (0.192" diameter) by 2-1/2" long and are included with KB, KHB, and KHW hangers.  
 6) KHW Glulam load values are based on 560 psi perpendicular to grain loading.

# TOP MOUNT HANGER CHARTS CONTINUED



©Copyright 2011 USP Structural Connectors®

Beam/ Joist Size	USP Stock No.	Ref. No.	Steel Gauge	Dimensions					Fastener Schedule <sup>3,4,5</sup>				Allowable Loads (Lbs.) <sup>6</sup>				Code Ref.	
				W	H	D	L	TF	Header		Joist		DF-L / SP					
									Qty	Type	Qty	Type	Floor	Roof	Uplift <sup>1,2</sup>			
				100%	115%	125%	160%											
(2) 2 x 12	SWH212-2	WNP212-2	7/12	3-1/8	11-1/8	2-1/2	7	2-1/2	2	---	10d	2	10d	3305	3305	3305	---	8, F14, R9
	HDO212-2	HU212-2TF, HUS212-2TF	12	3-1/8	11	2-1/2	---	2-1/2	4	12	16d	6	10d	4880	5230	5465	1220	5, F30, R5
(2) 2 x 14	SWH214-2	WNP214-2	7/12	3-1/8	13-1/8	2-1/2	7	2-1/2	2	---	10d	2	10d	3305	3305	3305	---	8, F14, R9
	HDO214-2	HU214-2TF, HUS214-2TF	12	3-1/8	13	2-1/2	---	2-1/2	4	14	16d	8	10d	5175	5410	5410	1625	5, F30, R5
(2) 2 x 16	SWH216-2	WNP216-2	7/12	3-1/8	15-1/8	2-1/2	7	2-1/2	2	---	10d	2	10d	3305	3305	3305	---	8, F14, R9
	HDO216-2	HU216-2TF	12	3-1/8	15	2-1/2	---	2-1/2	4	16	16d	8	10d	5475	5855	5960	1625	5, F30, R5
4 x 4	HDO44	HU44TF	12	3-9/16	3-7/16	2-1/4	---	2-1/2	4	4	16d	2	10d	2445	2445	2445	405	5, F30, R5
4 x 6	SW46	W46	12	3-9/16	5-3/8	2-1/2	6-1/2	2-1/2	2	---	10d	2	10d	2520	2520	2520	---	8, F14, R9
	HDO46	HU46TF, HUS46TF	12	3-9/16	5-3/8	2-1/4	---	2-1/2	4	6	16d	4	10d	3050	3050	3050	815	5, F30, R5
	KHW46	HW46	3/10	3-9/16	5-3/8	2-1/2	10	2-1/2	4	---	NA20D	2	10d	5335	5335	5335	---	8, F14, R9
4 x 8	SW48	W48	12	3-9/16	7-1/8	2-1/2	6-1/2	2-1/2	2	---	10d	2	10d	2520	2520	2520	---	8, F14, R9
	HDO48	B48, BA48, HU48TF, HUS48TF	12	3-9/16	7-1/8	2-1/4	---	2-1/2	4	8	16d	4	10d	3825	3825	3825	815	5, F30, R5
	KHW48	HW48	3/10	3-9/16	7-1/8	2-1/2	10	2-1/2	4	---	NA20D	2	10d	5335	5335	5335	---	8, F14, R9
4 x 10	SW410	W410	12	3-9/16	9-1/8	2-1/2	6-1/2	2-1/2	2	---	10d	2	10d	2520	2520	2520	---	8, F14, R9
	HDO410	B410, HU410TF, HUS410TF	12	3-9/16	9-1/8	2-1/4	---	2-1/2	4	10	16d	6	10d	4565	4565	4565	1220	5, F30, R5
	SWH410	---	7/12	3-9/16	9-1/8	2-1/2	7	2-1/2	2	---	10d	2	10d	3305	3305	3305	---	8, F14, R9
	KHW410	HW410	3/10	3-9/16	9-1/8	2-1/2	10	2-1/2	4	---	NA20D	2	10d	5335	5335	5335	---	8, F14, R9
4 x 12	HDO412	B412, HU412TF, HUS412TF	12	3-9/16	11	2-1/4	---	2-1/2	4	12	16d	6	10d	4880	5230	5465	1220	5, F30, R5
	SWH412	WNP412	7/12	3-9/16	11-1/8	2-1/2	7	2-1/2	2	---	10d	2	10d	3305	3305	3305	---	8, F14, R9
	KHW412	HW412	3/10	3-9/16	11-1/8	2-1/2	10	2-1/2	4	---	NA20D	2	10d	5335	5335	5335	---	8, F14, R9
4 x 14	HDO414	B414, HHB414, HU414TF, HUI414TF, HUS414TF	12	3-9/16	13	2-1/2	---	2-1/2	4	14	16d	8	10d	5175	5410	5410	1625	5, F30, R5
	SWH414	WNP414	7/12	3-9/16	13-1/8	2-1/2	7	2-1/2	2	---	10d	2	10d	3305	3305	3305	---	8, F14, R9
	KHW414	HW414	3/10	3-9/16	13-1/8	2-1/2	10	2-1/2	4	---	NA20D	2	10d	5335	5335	5335	---	8, F14, R9
4 x 16	HDO416	B416, HHB416, HU416TF	12	3-9/16	15	2-1/2	---	2-1/2	4	16	16d	8	10d	5475	5915	6210	1625	5, F30, R5
	SWH416	WNP416	7/12	3-9/16	15-1/8	2-1/2	7	2-1/2	2	---	10d	2	10d	3305	3305	3305	---	8, F14, R9
	KHW416	HW416	3/10	3-9/16	15-1/8	2-1/2	10	2-1/2	4	---	NA20D	2	10d	5335	5335	5335	---	8, F14, R9
(3) 2 x 10	HDO210-3	HU210-3TF	12	4-11/16	9-1/8	2-1/2	---	2-1/2	4	10	16d	6	16d	4565	4565	4565	1430	5, F30, R5
(3) 2 x 12	HDO212-3	HU212-3TF	12	4-11/16	11	2-1/2	---	2-1/2	4	12	16d	6	16d	4880	5230	5465	1430	5, F30, R5

- 1) Uplift Loads have been increased 60% for wind or seismic loads; no further increase shall be permitted.
- 2) HL, KHW, SW, and SWH products do not provide uplift resistance, except for the HL214.
- 3) Minimum nail embedment shall be 1-1/2" for 10d nails, 1-5/8" for 16d nails, and 2" for NA20D nails.
- 4) 10d x 1-1/2 nails are 9 gauge (0.148" diameter) by 1-1/2" long.
- 5) NA20D nails are 6 gauge (0.192" diameter) by 2-1/2" long and are included with KB, KHB, and KHW hangers.
- 6) KHW Glulam load values are based on 560 psi perpendicular to grain loading.

continued on next page

Beam/ Joist Size	USP Stock No.	Ref. No.	Steel Gauge	Dimensions					Fastener Schedule <sup>2,3,4,5</sup>				Allowable Loads (Lbs.) <sup>6</sup>				Code Ref.	
				W	H	D	L	TF	Header		Joist		DF-L / SP					
									Qty	Type	Qty	Type	Floor	Roof	Uplift <sup>1</sup>			
				100%	115%	125%	160%											
(3) 2 x 14	HDO214-3	HU214-3TF	12	4-11/16	13	2-1/2	---	2-1/2	4	14	16d	8	16d	5175	5410	5410	1710	5, F30, R5
(3) 2 x 16	HDO216-3	HU216-3TF	12	4-11/16	15	2-1/2	---	2-1/2	4	16	16d	8	16d	5475	5915	6210	1905	5, F30, R5
6 x 6	HDO66	HU66TF	12	5-1/2	5-3/8	2-1/2	---	2-1/2	4	6	16d	4	16d	3050	3050	3050	955	5, F30, R5
	SWH66	WNP66	7/12	5-1/2	5-3/8	2-1/2	7	2-1/2	2	---	10d	2	10d	3305	3305	3305	---	8, F14, R9
	KHW66	HW66	3/10	5-1/2	5-3/8	2-1/2	10	2-1/2	4	---	NA20D	2	10d	5335	5335	5335	---	8, F14, R9
6 x 8	HDO68	HHB68, HU68TF	12	5-1/2	7-1/8	2-1/2	---	2-1/2	4	8	16d	4	16d	3825	3825	3825	955	5, F30, R5
	SWH68	WNP68	7/12	5-1/2	7-1/8	2-1/2	7	2-1/2	2	---	10d	2	10d	3305	3305	3305	---	8, F14, R9
	KHW68	HW68	3/10	5-1/2	7-1/8	2-1/2	10	2-1/2	4	---	NA20D	2	10d	5335	5335	5335	---	8, F14, R9
6 x 10	HDO610	B610, HHB610, HU610TF	12	5-1/2	9-1/8	2-1/2	---	2-1/2	4	10	16d	6	16d	4565	4565	4565	1430	5, F30, R5
	SWH610	WNP610	7/12	5-1/2	9-1/8	2-1/2	7	2-1/2	2	---	10d	2	10d	3305	3305	3305	---	8, F14, R9
	KHW610	HW610	3/10	5-1/2	9-1/8	2-1/2	10	2-1/2	4	---	NA20D	2	10d	5335	5335	5335	---	8, F14, R9
6 x 12	HDO612	B612, HHB612, HU612TF	12	5-1/2	11	2-1/2	---	2-1/2	4	12	16d	6	16d	4880	5230	5465	1430	5, F30, R5
	KHW612	HW612	3/10	5-1/2	11-1/8	2-1/2	10	2-1/2	4	---	NA20D	2	10d	5335	5335	5335	---	8, F14, R9
6 x 14	HDO614	B614, HHB614, HU614TF	12	5-1/2	13	2-1/2	---	2-1/2	4	14	16d	8	16d	5175	5410	5410	1710	5, F30, R5
	KHW614	HW614	3/10	5-1/2	13-1/8	2-1/2	10	2-1/2	4	---	NA20D	2	10d	5335	5335	5335	---	8, F14, R9
6 x 16	HDO616	B616, HHB616, HU616TF	12	5-1/2	15	2-1/2	---	2-1/2	4	16	16d	8	16d	5475	5915	6210	1905	5, F30, R5
	KHW616	HW616	3/10	5-1/2	15-1/8	2-1/2	10	2-1/2	4	---	NA20D	2	10d	5335	5335	5335	---	8, F14, R9
8 x 6	KHW86	HW86	3/10	7-1/2	5-3/8	2-1/2	10	2-1/2	4	---	NA20D	2	10d	5335	5335	5335	---	8, F14, R9
8 x 8	KHW88	HW88	3/10	7-1/2	7-1/8	2-1/2	10	2-1/2	4	---	NA20D	2	10d	5335	5335	5335	---	8, F14, R9
8 x 10	KHW810	HW810	3/10	7-1/2	9-1/8	2-1/2	10	2-1/2	4	---	NA20D	2	10d	5335	5335	5335	---	8, F14, R9
8 x 12	KHW812	HHB812, HW812	3/10	7-1/2	11-1/8	2-1/2	10	2-1/2	4	---	NA20D	2	10d	5335	5335	5335	---	8, F14, R9
8 x 14	KHW814	HHB814, HW814	3/10	7-1/2	13-1/8	2-1/2	10	2-1/2	4	---	NA20D	2	10d	5335	5335	5335	---	8, F14, R9
8 x 16	KHW816	HHB816, HW816	3/10	7-1/2	15-1/8	2-1/2	10	2-1/2	4	---	NA20D	2	10d	5335	5335	5335	---	8, F14, R9
Glulam Sizes <sup>6</sup>																		
2-1/2 glulam	KHW26	---	3/10	2-11/16	specify	4	10	2-1/2	4	---	NA20D	2	10d x 1-1/2	5295	5295	5295	---	8, F14, R9
3-1/8 glulam	KHW3	HW3.25	3/10	3-1/4	specify	3	10	2-1/2	4	---	NA20D	2	10d	5295	5295	5295	---	8, F14, R9
5-1/8 glulam	KHW5	HW5.25	3/10	5-1/4	specify	2-1/2	10	2-1/2	4	---	NA20D	2	10d	5295	5295	5295	---	8, F14, R9

- 1) Uplift Loads have been increased 60% for wind or seismic loads; no further increase shall be permitted.
- 2) Minimum nail embedment shall be 1-1/2" for 10d nails, 1-5/8" for 16d nails, and 2" for NA20D nails.
- 3) 10d x 1-1/2" nails are 9 gauge (0.148" diameter) by 1-1/2" long.
- 4) NA20D nails are 6 gauge (0.192" diameter) by 2-1/2" long and are included with KB, KHB, and KHW hangers.
- 5) KHW Glulam load values are based on 560 psi perpendicular to grain loading.
- 6) Consult USP for additional Glulam sizes.

These strap-style hangers are designed to support trusses, joists, or purlins. JH models may be bent along the flange allowing builders to use the hangers in top mount, face mount, or combination applications.

**Materials:** 18 gauge  
**Finish:** G90 galvanizing  
**Codes:** ESR-2104, FL820, LA City RR 25745

**Installation:**

- Use all specified fasteners. See Product Notes, page 11.
- Joist nails must be driven at a 30° to 45° angle through the joist or truss into the header to achieve listed loads. **Standard length “double shear” nails must be used to achieve listed load values.**
- If installing in top mount configuration, field bend top flange over header.
- 16d sinkers (9 gauge x 3 1/4”) may be used where 10d common are specified with no load reduction.

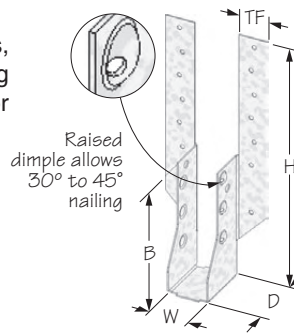

**JH20**

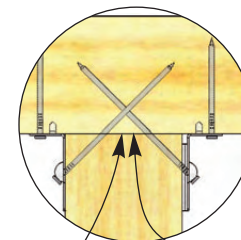

Double shear nail design features fewer nails and faster installation

©Copyright 2011 USP Structural Connectors®

Joist Size	USP Stock No.	Ref. No.	Steel Gauge	Dimensions					Header Size	Fastener Schedule <sup>2,3</sup>					Allowable Loads (Lbs.)				Code Ref.	
				W	H	D	B	TF		Header		Joist			DF-L / SP					
										Top	Face	Qty	Type	Qty	Type	100%	115%	125%		160%
										Qty	Type									
2 x 6 - 12	JH20	---	18	1-9/16	10-1/16	2-1/4	5-1/8	1-3/16	2 x 6	2	4	10d	6	10d	1900	2060	2165	1285	8, F14, R9	
								1-7/16	2 x 8	2	8	10d	6	10d	2540	2765	2900	1285		
								7/16	2 x 10	2	12	10d	6	10d	2270	2565	2760	1285		
								---	2 x 12	---	14	10d	6	10d	2185	2510	2730	1285		

1) Uplift Loads have been increased 60% for wind or seismic loads; no further increase shall be permitted.  
 2) Nails must be driven at a 30° to 45° angle through the joist or truss into header to achieve the table loads.  
 3) 16d sinkers (9 gauge x 3-1/4" long) may be used where 10d commons are specified with no reduction in load.

## LIGHT SLOPE HANGERS – LS SERIES

A field-adjustable seat gives the LS hanger application flexibility. The LS hanger slopes from 0° to 30° down (0 to 7:12 pitch down).

**Materials:** 18 gauge  
**Finish:** G90 galvanizing  
**Codes:** ESR-1465, FL817

**Installation:**

- Use all specified fasteners. See Product Notes, page 11.
- The **LS** can be field adjusted to slopes from 0° to 30° down.

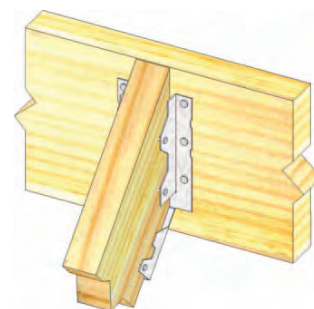

**Typical LS268 installation**

Joist Size	USP Stock No.	Ref. No.	Steel Gauge	Dimensions		Fastener Schedule <sup>2,3</sup>				Allowable Loads (Lbs.)				Code Ref.
				W	H	Header		Joist		DF-L / SP				
						Qty	Type	Qty	Type	100%	115%	125%	160%	
2 x 6 - 8	LS268	---	18	1-9/16	5-1/2	7	10d x 1-1/2	7	10d x 1-1/2	785	900	980	675	11, F12
						7	16d	7	10d x 1-1/2	960	1105	1170	675	
2 x 10	LS210	---	18	1-9/16	7-7/8	9	10d x 1-1/2	9	10d x 1-1/2	1010	1160	1260	1035	
						9	16d	9	10d x 1-1/2	1235	1370	1370	1035	

1) Uplift loads are increased 60% for wind or seismic loads; no further increase shall be permitted.  
 2) Minimum nail embedment shall be 1-1/2" for 10d nails and 1-5/8" for 16d nails.  
 3) 10d x 1-1/2 nails are 9 gauge (0.148" diameter) by 1-1/2" long.

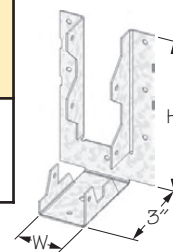

**LS268**

**Hangers**

**SKH** – Standard 45° skew hanger allows for a 40° to 50° skew range, without hanger modification.

**SKHH** – For heavier applications.

**Materials:** 14 or 16 gauge

**Finish:** G90 galvanizing; SKH26L/R-GC & SKH210L/R-GC – Gold Coat

**Options:** SKH26L/R, SKH28L/R, & SKH210L/R are available in Triple Zinc. To order, add *TZ* to stock number, as in **SKH26L-TZ**.

SKH26L/R, & SKH210L/R are available in Stainless Steel. To order, add *SS* to stock number, as in **SKH26L-SS**.

**Codes:** ESR-1781, **FL13285**,

Dade County, FL 07-0214.20, FL570, **L.A. City RR 25843**

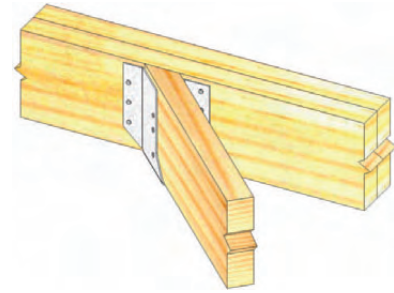

**SKH26R**  
Right skew

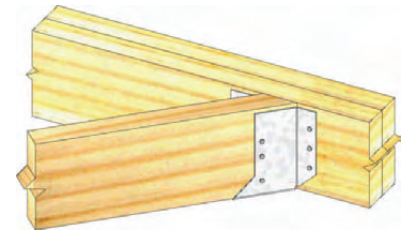

**SKH26L**  
Left skew

**Installation:**

- Use all specified fasteners. See Product Notes, page 11.
- The hangers listed are for standard sizes and will accommodate a 40° to 50° skew range.
- Most sizes do not require a miter cut for installation. Refer to chart footnote identified with an asterisk.
- Illustrations show left and right skews. (**SKH\_L** = skewed left; **SKH\_R** = skewed right)
- For I-Joist installations, web stiffeners are required.
- Refer to illustration for staggered I-Joist application for double 2", 2<sup>5</sup>/<sub>16</sub>", and 2<sup>1</sup>/<sub>2</sub>" models.
- For double I-Joist installations, web stiffeners between I-Joists are required.

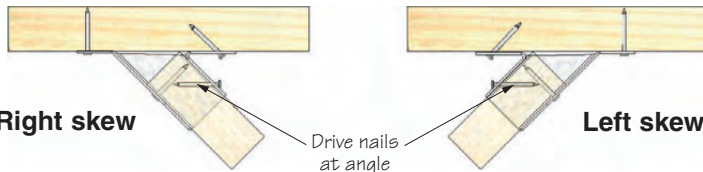

AVAILABLE IN  
**GOLD  
COAT**

Beam / Joist Size	USP Stock No.	Ref. No.	Steel Gauge	Dimensions			Fastener Schedule <sup>2,3</sup>				Allowable Loads (Lbs.)						Code Ref.		
				W	H	D	Header		Joist		DF-L / SP				S-P-F				
							Qty	Type	Qty	Type	Floor	Roof	Uplift <sup>1</sup>	Floor	Roof	Uplift <sup>1</sup>			
2 x 4	SKH24L/R	SUR/L24	16	1-9/16	3-1/4	1-7/8	4	16d	4	10d x 1-1/2	510	510	510	565	475	510	510	565	5, F30, R5
2 x 6 - 8	SKH26L/R	SUR/L26	16	1-9/16	5-1/4	1-7/8	6	16d	6	10d x 1-1/2	830	890	890	1085	715	820	890	930	5, F6, F30, D3, R5
	SKH26L/R-GC	---					6	N16C-GC	6	N10-GC									
2 x 8 - 10 - 12	SKH28L/R	---	16	1-9/16	7-1/4	1-7/8	10	16d	8	10d x 1-1/2	1380	1465	1465	1360	1190	1370	1465	1240	
2 x 10 - 12 - 14	SKH210L/R	SUR/L210, SUR/L214	16	1-9/16	9-1/4	1-7/8	14	16d	10	10d x 1-1/2	1790	1790	1790	1565	1665	1790	1790	1550	
	SKH210L/R-GC	---					14	N16C-GC	10	N10-GC									
1 3/4 x 9-1/4 - 14	SKH1720L/R	SUR/L1.81/9	16	1-13/16	9-1/8	1-7/8	14	10d	10	10d x 1-1/2	1625	1870	2030	1565	1400	1610	1750	1550	
1-3/4 x 11-1/4 - 18	SKH1724L/R	SUR/L1.81/11, SUR/L1.81/14	16	1-13/16	11-1/8	1-7/8	16	10d	10	10d x 1-1/2	1855	2135	2320	1565	1600	1840	2000	1550	
2 - 2-1/8 x 9-1/4 - 14	SKH2020L/R	SUR/L12.06/9, SUR/L2.1/9	16	2-1/8	9	1-7/8	14	10d	10	10d x 1-1/2	1625	1870	2030	1565	1400	1610	1750	1550	
2 - 2-1/8 x 11-1/4 - 18	SKH2024L/R	SUR/L2.06/11, SUR/L2.1/11	16	2-1/8	11	1-7/8	16	10d	10	10d x 1-1/2	1855	2135	2320	1565	1600	1840	2000	1550	
2-1/4 - 2-5/16 x 9-1/4 - 14	SKH2320L/R	SUR/L2.37/9	16	2-3/8	8-7/8	1-7/8	14	10d	10	10d x 1-1/2	1625	1870	2030	1565	1400	1610	1750	1550	5, F30, R5
2-1/4 - 2-5/16 x 11-1/4 - 18	SKH2324L/R	SUR/L2.37/11, SUR/L2.37/14	16	2-3/8	10-7/8	1-7/8	16	10d	10	10d x 1-1/2	1855	2135	2320	1565	1600	1840	2000	1550	
3 x 6 - 8	SKH36L	---	16	2-9/16	4-3/4	1-3/8	6	16d	6	10d x 1-1/2	830	950	1025	1085	715	820	895	930	
3 x 8 - 10 - 12	SKH38L/R	---	16	2-9/16	6-3/4	1-3/8	10	16d	8	10d x 1-1/2	1380	1585	1585	1360	1190	1370	1490	1240	
3 x 10 - 12 - 14	SKH310L/R	---	16	2-9/16	8-3/4	1-3/8	14	16d	10	10d x 1-1/2	1930	2220	2250	1565	1665	1915	2085	1550	
3 x 12 - 14 - 16	SKH312L/R	---	16	2-9/16	10-3/4	1-3/8	16	16d	10	10d x 1-1/2	2210	2500	2500	1565	1905	2190	2380	1550	
2-1/2 x 9-1/4 - 14	SKH2520L/R	SUR/L2.56/9	16	2-9/16	8-5/8	1-7/8	14	10d	10	10d x 1-1/2	1625	1870	2030	1565	1400	1610	1750	1550	
2-1/2 x 11-1/4 - 16	SKH2524L/R	SUR/L2.56/11, SUR/L2.56/14	16	2-9/16	10-3/4	1-7/8	16	10d	10	10d x 1-1/2	1855	2135	2320	1565	1600	1840	2000	1550	
2-5/8 x 9-1/4 - 14	SKH2620L/R	---	16	2-11/16	8-11/16	1-7/8	14	10d	10	10d x 1-1/2	1625	1870	2030	1565	1400	1610	1750	1550	
2-5/8 x 11-1/4 - 16	SKH2624L/R	---	16	2-11/16	10-11/16	1-7/8	16	10d	10	10d x 1-1/2	1855	2135	2320	1565	1600	1840	2000	1550	

1) Uplift loads have been increased 60% for wind and seismic loads; no further increase shall be permitted.

2) 10d x 1-1/2 nails and N10-GC are 9 gauge (0.148" diameter) by 1-1/2" long.

3) Minimum nail embedment shall be 1-1/2" for 10d nails and 1-5/8" for 16d and N16C-GC nails.

continued on next page

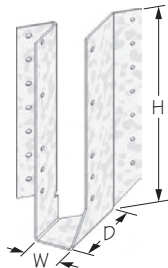

**SKH210L**

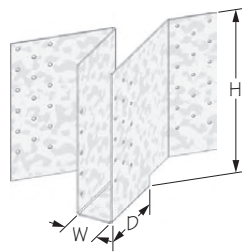

**SKHH210L**

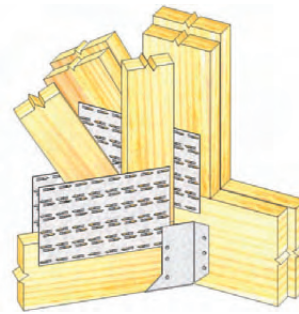

**Typical SKH26L installation  
Left skew**

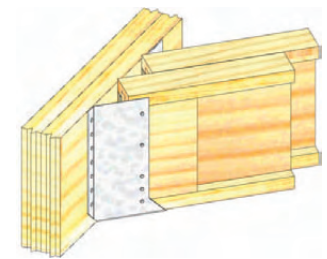

**Typical SKH2520R-2 staggered I-Joist installation  
Right skew**

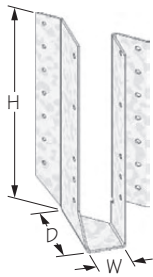

**SKH210R**

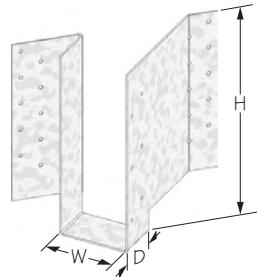

**SKHH210L-2**

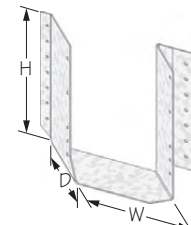

**SKH2520R-2**

© Copyright 2011 USP Structural Connectors®

Beam / Joist Size	USP Stock No.	Ref. No.	Steel Gauge	Dimensions			Fastener Schedule <sup>2,3,4</sup>				Allowable Loads (Lbs.)						Code Ref.			
				W	H	D	Header		Joist		DF-L / SP			S-P-F						
							Qty	Type	Qty	Type	Floor	Roof	Uplift <sup>1</sup>	Floor	Roof	Uplift <sup>1</sup>				
(2) 2 x 6 - 8	SKH26L/R-2 *	SUR/L26-2	16	3-1/16	4-1/2	1-3/8	6	16d	6	10d	830	950	1035	1115	715	820	895	960	5, F30, R5	
(2) 2 x 8 - 10 - 12	SKH28L/R-2 *	---	16	3-1/16	6-1/2	1-3/8	10	16d	8	10d	1380	1585	1725	1360	1190	1370	1490	1280		
(2) 2 x 10 - 12 - 14	SKH210L/R-2 *	SUR/L210-2, SUR/L214-2	16	3-1/16	8-1/2	1-3/8	14	16d	10	10d	1930	2220	2415	1565	1665	1915	2085	1565		
3-1/2 x 8 - 14	SKH410L/R *	SUR/L410	14	3-9/16	8-1/2	2-1/2	16	16d	10	16d	2255	2540	2540	1565	1935	2225	2420	1565		
3-1/2 x 12 - 18	SKH414L/R *	SUR/L414	14	3-9/16	12-1/2	2-1/2	22	16d	10	16d	3100	3565	3880	1565	2660	3060	3330	1565		
4 x 6 - 8	SKH46L/R *	SUR/L46	14	3-9/16	4-3/4	2-1/2	10	16d	6	16d	1410	1590	1590	1355	1210	1390	1515	1160		
4 x 10 - 12 - 14	SKH410L/R *	SUR/L410	14	3-9/16	8-1/2	2-1/2	16	16d	10	16d	2255	2540	2540	1565	1935	2225	2420	1565		
4 x 14 - 16 - 18	SKH414L/R *	SUR/L414	14	3-9/16	12-1/2	2-1/2	22	16d	10	16d	3100	3565	3880	1565	2660	3060	3330	1565		
(2) 2 - 2-1/8 x 9-1/4 - 14	SKH2020L/R-2	HSUR/L4.12/9, HSUR/L4.28/9	14	4-3/16	9-1/4	3-1/2	14	10d	10	10d	1665	1915	2085	1905	1440	1660	1805	1650		
(2) 2 - 2-1/8 x 11-1/4 - 18	SKH2024L/R-2	HSUR/L4.12/11, HSUR/L4.12/14, HSUR/L4.12/16, HSUR/L4.28/11	14	4-3/16	11-1/4	3-1/2	16	10d	10	10d	1905	2190	2380	1905	1650	1895	2060	1650		
(2) 2-5/16 x 9-1/4 - 14	SKH2320L/R-2	HSUR/L4.75/9	14	4-7/8	9-1/4	3-1/2	14	10d	10	10d	1665	1915	2085	1905	1440	1660	1805	1650		
(2) 2-5/16 x 11-1/4 - 18	SKH2324L/R-2	HSUR/L4.75/11, HSUR/L4.75/14, HSUR/L4.75/16	14	4-7/8	11-1/4	3-1/2	16	10d	10	10d	1905	2190	2380	1905	1650	1895	2060	1650		
(2) 2-1/2 x 9-1/4 - 14	SKH2520L/R-2	HSUR/L5.12/9	14	5-1/8	9-1/4	3-1/2	14	10d	10	10d	1665	1915	2085	1905	1440	1660	1805	1650		
(2) 2-1/2 x 11-1/4 - 16	SKH2524L/R-2	HSUR/L5.12/11, HSUR/L5.12/14, HSUR/L5.12/16	14	5-1/8	11-1/4	3-1/2	16	10d	10	10d	1905	2190	2380	1905	1650	1895	2060	1650		
2 x 6 - 8	SKHH26L/R	---	14	1-5/8	5-1/8	3-1/4	18	16d	12	10d x 1-1/2	1510	1740	1890	2190	1305	1505	1635	1900		130
2 x 8 - 10 - 12	SKHH28L/R	---	14	1-5/8	7	3-1/4	26	16d	16	10d x 1-1/2	2185	2510	2730	2920	1890	2170	2360	2535		
2 x 10 - 12 - 14	SKHH210L/R	---	14	1-5/8	9	4-1/4	34	16d	20	10d x 1-1/2	2855	3285	3570	3650	2470	2840	3085	3170		
(2) 2 x 6 - 8	SKHH26L/R-2	HSUR/L26-2	14	3-1/16	5-1/4	2	12	16d	4	16d x 2-1/2	1680	1930	2100	895	1450	1670	1815	775		
(2) 2 x 10 - 12 - 14	SKHH210L/R-2	HSUR/L210-2, HSUR/L214-2	14	3-1/16	8-1/2	2	20	16d	6	16d x 2-1/2	2800	3220	3500	1345	2420	2785	3025	1160		
4 x 6 - 8	SKHH46L/R	HSUR/L46	14	3-9/16	5-1/4	2-1/2	12	16d	6	16d	1680	1930	2100	1345	1450	1670	1815	1160		
4 x 10 - 12 - 14	SKHH410L/R	HSUR/L410	14	3-9/16	8-1/2	2-1/2	20	16d	10	16d	2800	3220	3500	2240	2420	2785	3025	1935		
4 x 14 - 16 - 18	SKHH414L/R	HSUR/L414	14	3-9/16	12-1/2	2-1/2	26	16d	10	16d	3640	4185	4550	2240	3145	3620	3935	1935		

1) Uplift loads have been increased 60% for wind and seismic loads; no further increase shall be permitted.  
 2) 10d x 1-1/2 nails are 9 gauge (0.148" diameter) by 1-1/2" long.  
 3) 16d x 2-1/2 nails are 8 gauge (0.162" diameter) by 2-1/2" long.  
 4) Minimum nail embedment shall be 1-1/2" for 10d nails and 1-5/8" for 16d nails.  
 \*Miter cut required on end of joist to achieve design loads.

**KF** – Fastens to joist ends quickly with nails.

**PHG** – Features a gripper design to hold the joist in place without nailing during the assembly process.

**Materials:** 18 gauge  
**Finish:** G90 galvanizing  
**Codes:** ESR-1280, FL11664, L.A. City RR 25749

**Installation:**

- Use all specified fasteners. See Product Notes, page 11.
- In panelized construction, installers are allowed to nail through both the sheathing and the hanger top flange with (1) 10d nail. The nail should be centered in the top flange and be no closer than 1/4" from the back or front edge of the top flange.
- Use locator window to center hanger on purlin center line.

**• KF & PHG – These hangers do not provide uplift resistance.**

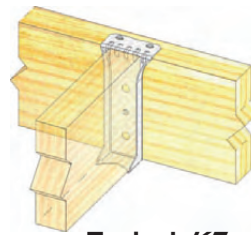

**Typical KF installation**

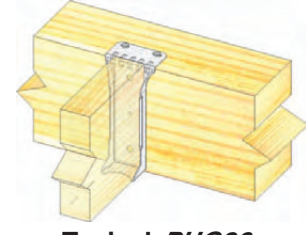

**Typical PHG26 installation**

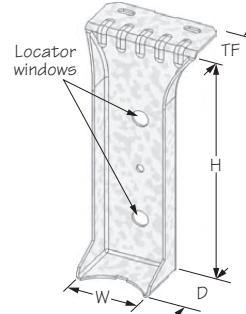

**KF**

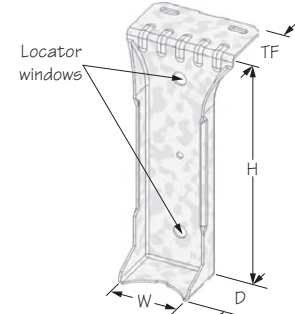

**PHG26**

Joist Size	USP Stock No.	Ref. No.	Steel Gauge	Dimensions				Fastener Schedule <sup>2,3</sup>				Allowable Loads (Lbs.) <sup>1</sup>	Code Ref.
				W	H	D	TF <sup>5</sup>	Header		Joist			
								Qty	Type	Qty	Type	DF-L / SP 125%	
2 x 4	PHG24	HF24N	18	1-9/16	3-1/2	1-3/16	1-1/16	2	8d	---	---	580	2, F20, R12
2 x 6	PHG26	F26P, HF26N	18	1-9/16	5-3/8	1	1-1/16	2	10d	---	---	650	
3 x 4	PHG34	HF34N	18	2-9/16	3-1/2	1	1-1/8	2	10d	---	---	650	
3 x 6	PHG36	HF36N	18	2-9/16	5-3/8	1	1-1/8	2	10d	---	---	650	
(2) 2 x 4	PHG24-2	F24-2	18	3-1/8	3-1/2	1	1-1/8	2	10d	---	---	650	
(2) 2 x 6	PHG26-2	F26-2	18	3-1/8	5-3/8	1	1-1/8	2	10d	---	---	650	
4 x 4	KF44	F44	18	3-9/16	3-3/8	1	1-1/8	2	10d	1	10d x 1-1/2	695	
4 x 6	KF46	F46	18	3-9/16	5-3/8	1	1-1/8	2	10d	1	10d x 1-1/2	810	

- 1) Loads listed are per side.
- 2) Minimum nail embedment shall be 1-5/16" for 8d nails and 1-1/2" for 10d nails.
- 3) 10d x 1-1/2 nails are 9 gauge (0.148" diameter) by 1-1/2" long.

## PURLIN HANGERS – JPF SERIES

**Materials:** 20 gauge  
**Finish:** G90 galvanizing  
**Codes:** ESR-1465, FL817

**Installation:**

- Use all specified fasteners. See Product Notes, page 11.
- Diamond holes allow optional header nailing.
- Joist nails must be driven at a 30° to 45° angle through the purlin into the header to achieve listed loads. **Standard length "double shear" nails must be used to achieve listed load values.**
- 16d sinkers (9 gauge x 3 1/4") may be used where 10d commons are specified with no load reduction.

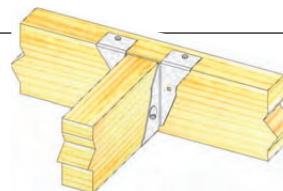

**Typical JPF24 installation**

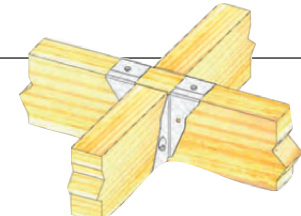

**Typical JPF24 back-to-back installation**

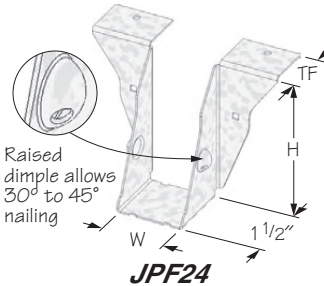

**JPF24**

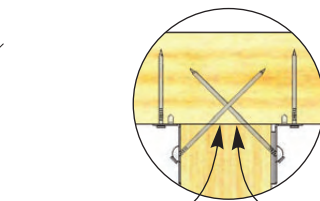

Double shear nail design features fewer nails and faster installation. Uses standard length nails.

Purlin Size	USP Stock No.	Ref. No.	Steel Gauge	Dimensions			Fastener Schedule <sup>3</sup>					Allowable Loads (Lbs.)							Code Ref.	
				W	H	TF	Header <sup>2</sup>		Joist			DF-L / SP				S-P-F				
							Qty	Qty	Type	Qty	Type	100%	115%	125%	160%	100%	115%	125%		160%
2 x 4	JPF24	PF24	20	1-9/16	3-3/8	1-1/16	2	---	10d	2	10d	1070	1070	1070	315	800	800	800	235	11, F12
2 x 6	JPF26	PF26	20	1-9/16	5-3/8	1-1/16	2	---	10d	2	10d	1275	1275	1275	470	950	950	950	350	
							2	2	10d	2	10d	1070	1070	1070	315	800	800	800	235	

1) Uplift loads have been increased 60% for wind and seismic loads; no further increase shall be permitted.  
 2) JPF cannot be used back to back on a single ply header when optional nailing is used.  
 3) Minimum nail embedment shall be 1-1/2" for 10d nails.

**Materials:** 18 gauge  
**Finish:** G90 galvanizing

**Installation:**

- Use all specified fasteners. See Product Notes, page 11.
- Joist nails must be driven at a 30° to 45° angle through the purlin into the header to achieve listed loads. **Standard length “double shear” nails must be used to achieve listed load values.**

©Copyright 2011 USP Structural Connectors®

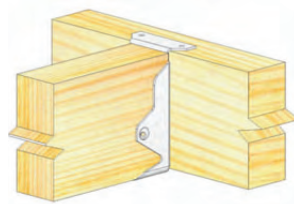
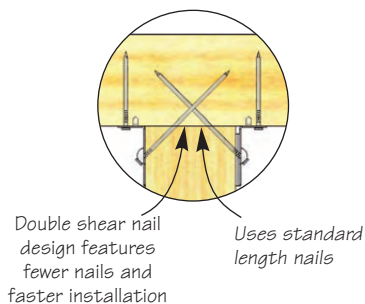

**Typical JDS24S installation**

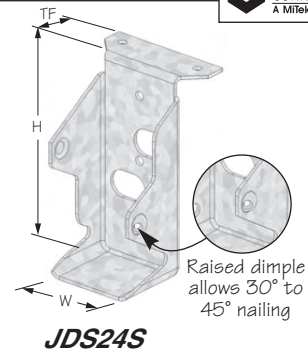

**JDS24S**

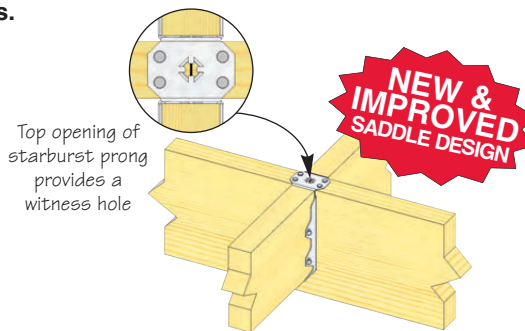

**Typical JDS26 installation**

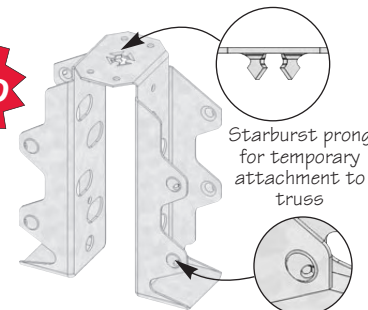

**JDS26 (JDS24 similar)**

Raised dimple allows 30° to 45° nailing

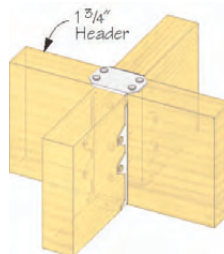

**JDS26-175 installation**



**JDS26-175**

Purlin Size	USP Stock No.	Ref. No.	Steel Gauge	Dimensions			Fastener Schedule <sup>2,3</sup>					Allowable Loads (Lbs.)				Code Ref.
				W	H	TF	Header		Each Purlin			DF-L / SP				
							Top	Face	Qty	Type	Qty	Type	Floor	Roof	Uplift <sup>1</sup>	
							Qty	Qty								
2 x 4 single	JDS24S Min	PF24A	18	1-9/16	3-1/2	3/4	1	2	10d x 1-1/2	2	10d x 1-1/2	480	480	480	180	110
	JDS24S Max						2	---	10d x 1-1/2	2	10d	575	575	575	340	
2 x 6 single	JDS26S Min	PF26A	18	1-9/16	5-1/2	3/4	1	2	10d x 1-1/2	4	10d x 1-1/2	550	550	550	300	
	JDS26S Max						2	---	10d x 1-1/2	4	10d	775	830	835	390	
2 x 4 saddle	JDS24 Min	PFD24	18	1-9/16	3-1/2	1-9/16	2	4	10d x 1-1/2	2	10d x 1-1/2	960	960	960	360	
	JDS24 Max						4	---	10d x 1-1/2	4	10d	1155	1155	1155	680	
2 x 6 saddle	JDS26-175	---	18	1-9/16	5-7/16	1-3/4	2	4	10d x 1-1/2	4	10d x 1-1/2	1105	1105	1105	595	
	JDS26 Min	PFD26	18	1-9/16	5-1/2	1-9/16	2	4	10d x 1-1/2	4	10d x 1-1/2	1105	1105	1105	595	
	JDS26 Max						4	---	10d x 1-1/2	8	10d	1575	1670	1670	775	

1) Uplift loads have been increased 60% for wind and seismic loads; no further increase shall be permitted.

2) 10d x 1-1/2 nails are 9 gauge (0.148" diameter) by 1-1/2" long.

3) Minimum nail embedment shall be 1-1/2" for 10d nails.

New products or updated product information are designated in bold font.

**Hangers**

Versatile heavy-duty top flange hanger attaches to both wood and masonry. Unique design allows builders to use one style hanger on the job when the structure has a variety of support materials.

- Materials:** Top Flange – 1/4" steel; Stirrup – 7 gauge  
**Finish:** USP primer  
**Options:** See Specialty Options Chart on page 107.  
**Codes:** 2031C, FL859

**Installation:**

- Use all specified fasteners. See Product Notes, page 11.
- NA21 nails are included with hangers where specified.
- **NA21 nails are not recommended for use with LVL, PSL, or LSL headers.**
- Masonry design load values apply to both solid concrete tie beams and grout-filled CMU walls.
- **Alternate installation** – Use (2) 1/2" x 4" Powers Fasteners Wedge-Bolts® or equal for loads up to 2,400 lbs. when attaching to CMU. Loads shall not exceed table loads.

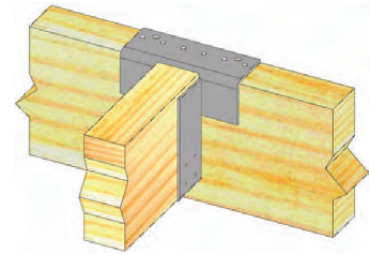

Typical *HWUH410*  
wood-to-wood installation

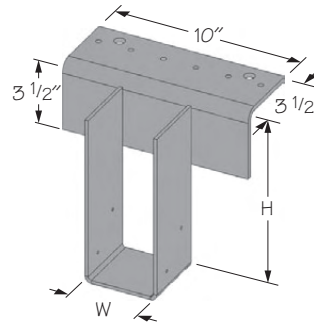

*HWUH410*

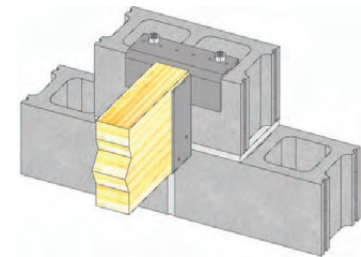

Typical *HWUH410*  
wood-to-masonry installation

© Copyright 2011 USP Structural Connectors®

Beam/ Joist Size	USP Stock No.	Ref. No.	Dimensions		Fastener Schedule <sup>1,3</sup>				Allowable Loads (Lbs.)				Code Ref.
			W	H	Header		Joist		DF-L / SP				
					Qty	Type	Qty	Type	Floor	Roof	Uplift <sup>4</sup>		
100%	115%	125%	160%										
2 x 4 - 6	HWUH26	---	1-5/8	5-3/8	6	10d	4	10d x 1-1/2	2265	2265	2265	930	L1, F17
					2	1/2 x 6 Emb. J-Bolt	4	10d x 1-1/2	2265	2265	2265	930	
2 x 8	HWUH28	---	1-5/8	7-1/8	6	10d	4	10d x 1-1/2	2265	2265	2265	930	
					2	1/2 x 6 Emb. J-Bolt	4	10d x 1-1/2	2265	2265	2265	930	
2 x 10	HWUH210	---	1-5/8	9-1/8	6	10d	4	10d x 1-1/2	2265	2265	2265	930	
					2	1/2 x 6 Emb. J-Bolt	4	10d x 1-1/2	2265	2265	2265	930	
2 x 12	HWUH212	---	1-5/8	11	6	10d	4	10d x 1-1/2	2265	2265	2265	930	
					2	1/2 x 6 Emb. J-Bolt	4	10d x 1-1/2	2265	2265	2265	930	
2 x 14	HWUH214	---	1-5/8	13	6	10d	4	10d x 1-1/2	2265	2265	2265	930	
					2	1/2 x 6 Emb. J-Bolt	4	10d x 1-1/2	2265	2265	2265	930	
2 x 16	HWUH216	---	1-5/8	16	6	10d	4	10d x 1-1/2	2265	2265	2265	930	
					2	1/2 x 6 Emb. J-Bolt	4	10d x 1-1/2	2265	2265	2265	930	
3 x 6	HWUH36	---	2-5/8	5-3/8	6	10d	4	10d	3800	3800	3800	1035	
					2	1/2 x 6 Emb. J-Bolt	4	10d	3800	3800	3800	1035	
3 x 8	HWUH38	---	2-5/8	7-1/8	6	10d	4	10d	3800	3800	3800	1035	
					2	1/2 x 6 Emb. J-Bolt	4	10d	3800	3800	3800	1035	
3 x 10	HWUH310	---	2-5/8	9-1/8	6	10d	4	10d	3800	3800	3800	1035	
					2	1/2 x 6 Emb. J-Bolt	4	10d	3800	3800	3800	1035	
3 x 12	HWUH312	---	2-5/8	11	6	10d	4	10d	3800	3800	3800	1035	
					2	1/2 x 6 Emb. J-Bolt	4	10d	3800	3800	3800	1035	
3 x 14	HWUH314	---	2-5/8	13	6	10d	4	10d	3800	3800	3800	1035	
					2	1/2 x 6 Emb. J-Bolt	4	10d	3800	3800	3800	1035	
3 x 16	HWUH316	---	2-5/8	16	6	10d	4	10d	3800	3800	3800	1035	
					2	1/2 x 6 Emb. J-Bolt	4	10d	3800	3800	3800	1035	
(2) 2 x 6	HWUH26-2	---	3-1/8	5-3/8	6	10d	4	10d	3800	3800	3800	1035	
					2	1/2 x 6 Emb. J-Bolt	4	10d	3800	3800	3800	1035	
(2) 2 x 8	HWUH28-2	---	3-1/8	7-1/8	6	10d	4	10d	3800	3800	3800	1035	
					2	1/2 x 6 Emb. J-Bolt	4	10d	3800	3800	3800	1035	
(2) 2 x 10	HWUH210-2	---	3-1/8	9-1/8	6	10d	4	10d	3800	3800	3800	1035	
					2	1/2 x 6 Emb. J-Bolt	4	10d	3800	3800	3800	1035	
(2) 2 x 12	HWUH212-2	---	3-1/8	11	6	10d	4	10d	3800	3800	3800	1035	
					2	1/2 x 6 Emb. J-Bolt	4	10d	3800	3800	3800	1035	
(2) 2 x 14	HWUH214-2	---	3-1/8	13	6	10d	4	10d	3800	3800	3800	1035	
					2	1/2 x 6 Emb. J-Bolt	4	10d	3800	3800	3800	1035	
(2) 2 x 16	HWUH216-2	---	3-1/8	16	6	10d	4	10d	3800	3800	3800	1035	
					2	1/2 x 6 Emb. J-Bolt	4	10d	3800	3800	3800	1035	



©Copyright 2011 USP Structural Connectors®

Beam/ Joist Size	USP Stock No.	Ref. No.	Dimensions		Fastener Schedule <sup>1,3</sup>				Allowable Loads (Lbs.)				Code Ref.
			W	H	Header		Joist		DF-L / SP				
					Qty	Type	Qty	Type	Floor	Roof		Uplift <sup>4</sup>	
100%	115%	125%	133%										
4 x 6	HWUH46	---	3-9/16	5-3/8	6	NA21	4	10d	5165	5165	5165	1035	L1, F17
					2	1/2 x 6 Emb. J-Bolt	4	10d	5165	5165	5165	1035	
4 x 8	HWUH48	---	3-9/16	7-1/8	6	NA21	4	10d	5165	5165	5165	1035	
					2	1/2 x 6 Emb. J-Bolt	4	10d	5165	5165	5165	1035	
4 x 10	HWUH410	---	3-9/16	9-1/8	6	NA21	4	10d	5165	5165	5165	1035	
					2	1/2 x 6 Emb. J-Bolt	4	10d	5165	5165	5165	1035	
4 x 12	HWUH412	---	3-9/16	11	6	NA21	4	10d	5165	5165	5165	1035	
					2	1/2 x 6 Emb. J-Bolt	4	10d	5165	5165	5165	1035	
4 x 14	HWUH414	---	3-9/16	13	6	NA21	4	10d	5165	5165	5165	1035	
					2	1/2 x 6 Emb. J-Bolt	4	10d	5165	5165	5165	1035	
4 x 16	HWUH416	---	3-9/16	16	6	NA21	4	10d	5165	5165	5165	1035	
					2	1/2 x 6 Emb. J-Bolt	4	10d	5165	5165	5165	1035	
6 x 6	HWUH66	---	5-1/2	5-3/8	6	NA21	4	10d	5165	5165	5165	1035	
					2	1/2 x 6 Emb. J-Bolt	4	10d	5165	5165	5165	1035	
6 x 8	HWUH68	---	5-1/2	7-1/8	6	NA21	4	10d	5165	5165	5165	1035	
					2	1/2 x 6 Emb. J-Bolt	4	10d	5165	5165	5165	1035	
6 x 10	HWUH610	---	5-1/2	9-1/8	6	NA21	4	10d	5165	5165	5165	1035	
					2	1/2 x 6 Emb. J-Bolt	4	10d	5165	5165	5165	1035	
6 x 12	HWUH612	---	5-1/2	11	6	NA21	4	10d	5165	5165	5165	1035	
					2	1/2 x 6 Emb. J-Bolt	4	10d	5165	5165	5165	1035	
6 x 14	HWUH614	---	5-1/2	13	6	NA21	4	10d	5165	5165	5165	1035	
					2	1/2 x 6 Emb. J-Bolt	4	10d	5165	5165	5165	1035	
6 x 16	HWUH616	---	5-1/2	16	6	NA21	4	10d	5165	5165	5165	1035	
					2	1/2 x 6 Emb. J-Bolt	4	10d	5165	5165	5165	1035	
8 x 6	HWUH86	---	7-1/2	5-3/8	6	NA21	4	10d	5165	5165	5165	1035	
					2	1/2 x 6 Emb. J-Bolt	4	10d	5165	5165	5165	1035	
8 x 8	HWUH88	---	7-1/2	7-1/8	6	NA21	4	10d	5165	5165	5165	1035	
					2	1/2 x 6 Emb. J-Bolt	4	10d	5165	5165	5165	1035	
8 x 10	HWUH810	---	7-1/2	9-1/8	6	NA21	4	10d	5165	5165	5165	1035	
					2	1/2 x 6 Emb. J-Bolt	4	10d	5165	5165	5165	1035	
8 x 12	HWUH812	---	7-1/2	11	6	NA21	4	10d	5165	5165	5165	1035	
					2	1/2 x 6 Emb. J-Bolt	4	10d	5165	5165	5165	1035	
8 x 14	HWUH814	---	7-1/2	13	6	NA21	4	10d	5165	5165	5165	1035	
					2	1/2 x 6 Emb. J-Bolt	4	10d	5165	5165	5165	1035	
8 x 16	HWUH816	---	7-1/2	16	6	NA21	4	10d	5165	5165	5165	1035	
					2	1/2 x 6 Emb. J-Bolt	4	10d	5165	5165	5165	1035	

- 1) 10d x 1-1/2 nails are 9 gauge (0.148" diameter) by 1-1/2" long.
- 2) NA21 nails are 6 gauge (0.192" diameter) by 1-3/4" long and are included with 4x, 6x, and 8x HWUH hangers.
- 3) Minimum nail embedment shall be 1-1/2" for 10d nails.
- 4) Uplift loads have been increased 60% for wind or seismic loads; no further increase shall be permitted.

### Specialty Options Chart – refer to Specialty Options pages 194, 196-197 for additional details.

Option	Skewed <sup>1,3</sup>	Sloped Seat <sup>2,3</sup>	Sloped / Skewed <sup>1,2,3</sup>	Top Flange Offset		Saddle
Range	1' to 45'	1' to 45'	See Sloped Seat and Skewed	---		---
Allowable Loads	100% of table load	100% of table load	100% of table load	Hanger Width 3-1/2" or less 3-9/16" to 5-1/2" 5-9/16" to 7-1/2"	% of table load: 60% 75% 85%	100% of table load per side
Ordering	Add SK, angle required, and right (R) or left (L), to product number. Ex. HWUH410-SK45R	Add SL, slope required, and up (U) or down (D), to product number. Ex. HWUH410-SL30D	See Sloped Seat and Skewed. Ex. HWUH410-SK45RSL30D	Add OS, and right (R) or left (L), to product number. Ex. HWUH410-OSL		Add SA, and saddle width required to product number. Ex. HWUH410-SA=5-1/2"

- 1) Skewed hangers with skews greater than 15° may have all joist nailing on outside flange.
- 2) Sloped or sloped / skewed hangers with slopes greater than 15° may have additional joist nails.
- 3) All sloped, skewed, or combinations require bevel cut on joist in all applications.

Hangers

These hangers are designed to support standard lumber joists, I-Joists, or beams. Easy installation into concrete block walls makes the MPH an attractive alternative to fabricating seats in masonry (or attaching ledgers) to support joists or beams.

**Materials:** 12 gauge

**Finish:** USP primer

**Options:** All nominal lumber sizes are available for rough/full size lumber. See Specialty Options Chart on page 109.

**Codes:** ESR-1781, FL13285, L.A. City RR 25843

**Installation:**

- Use all specified fasteners. See Product Notes, page 11.
- 16d duplex nails are not supplied with MPH hangers.
- Place hanger into position on top of concrete block. Install (2) 16d duplex nails (8 gauge or 0.162" dia. x 3 1/2" double head) through the top flange nail holes. Then continue laying the next course of block.
- A minimum of one course shall be laid over hanger top flange and one course below hanger top flange. Courses adjacent to the top flange shall be subsequently grouted.

• **These products do not provide uplift resistance.**

Install with (2) 16d duplex nails in grouted cells

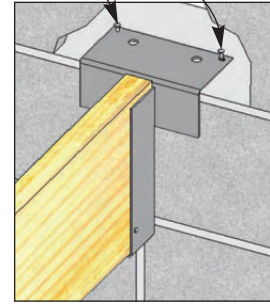

**Typical MPH single ply installation**

Install with (2) 16d duplex nails in grouted cells

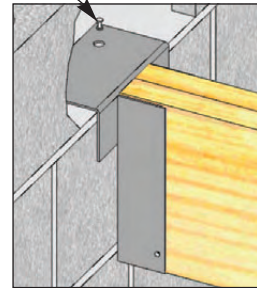

**Typical MPH double ply installation**

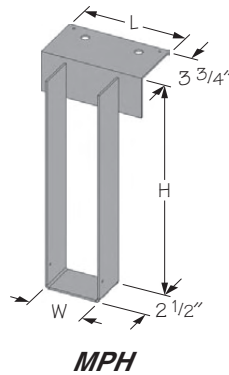

© Copyright 2011 USP Structural Connectors®

Beam/ Joist Size	USP Stock No.	Ref. No.	Steel Gauge	Dimensions			Fastener Schedule <sup>1,3,4</sup>				Allowable Loads (Lbs.) <sup>2</sup>			Code Ref.
				W	H	L	Masonry		Joist		DF-L / SP			
							Qty	Type	Qty	Type	Floor	Roof		
												100%	115%	
2 x 10	MPH210	WM210, WM29.25	12	1-9/16	9-1/4	7	2	16d duplex	2	10d x 1-1/2	2585	2620	2645	5, F30, R5
2 x 12	MPH212	WM211.25, WM212	12	1-9/16	11-1/4	7	2	16d duplex	2	10d x 1-1/2	2585	2620	2645	
2 x 14	MPH214	WM214	12	1-9/16	13-1/8	7	2	16d duplex	2	10d x 1-1/2	2585	2620	2645	
2 x 16	MPH216	WM216	12	1-9/16	15-1/8	7	2	16d duplex	2	10d x 1-1/2	2585	2620	2645	
(2) 2 x 10	MPH210-2	WM210-2, WM29.25-2	12	3-1/8	9-1/4	7	2	16d duplex	2	10d	4280	4280	4280	
(2) 2 x 12	MPH212-2	WM212-2	12	3-1/8	11-1/4	7	2	16d duplex	2	10d	4280	4280	4280	
(2) 2 x 14	MPH214-2	WM214-2	12	3-1/8	13-1/8	7	2	16d duplex	2	10d	4280	4280	4280	
(2) 2 x 16	MPH216-2	WM216-2	12	3-1/8	15-1/8	7	2	16d duplex	2	10d	4280	4280	4280	
3 x 10	MPH310	WM310	12	2-9/16	9-1/4	7	2	16d duplex	2	10d x 1-1/2	3240	3240	3240	
3 x 12	MPH312	WM312	12	2-9/16	11-1/4	7	2	16d duplex	2	10d x 1-1/2	3240	3240	3240	
3 x 14	MPH314	WM314	12	2-9/16	13-1/8	7	2	16d duplex	2	10d x 1-1/2	3240	3240	3240	
3 x 16	MPH316	WM316	12	2-9/16	15-1/8	7	2	16d duplex	2	10d x 1-1/2	3240	3240	3240	
4 x 10	MPH410	WM410	12	3-9/16	9-1/4	7	2	16d duplex	2	10d	4280	4280	4280	
4 x 12	MPH412	WM412	12	3-9/16	11-1/4	7	2	16d duplex	2	10d	4280	4280	4280	
4 x 14	MPH414	WM414	12	3-9/16	13-1/8	7	2	16d duplex	2	10d	4280	4280	4280	
4 x 16	MPH416	WM416	12	3-9/16	15-1/8	7	2	16d duplex	2	10d	4280	4280	4280	
6 x 10	MPH610	WM610	12	5-9/16	9-1/4	7	2	16d duplex	2	10d	4280	4280	4280	

1) 10d x 1-1/2 nails are 9 gauge (0.148" diameter) by 1-1/2" long.  
 2) Masonry compressive strength shall be minimum 1500 psi.  
 3) Duplex nails are No. 8 wire gauge (0.162" diameter) and 3-1/2" long, double headed nails and shall be installed in grouted cells in accordance to manufacturer's installation specifications.  
 4) Minimum nail embedment shall be 1-1/2" for 10d nails.

continued on next page

## Glulam sizes

Beam/ Joist Size	USP Stock No.	Ref. No.	Steel Gauge	Dimensions			Fastener Schedule <sup>1,3</sup>				Allowable Loads (Lbs.) <sup>1</sup>			Code Ref.
				W	H	L	Masonry		Joist		DF-L / SP			
							Qty	Type	Qty	Type	Floor	Roof		
3-1/8 x glulam	MPH325	---	12	3-1/4	specify	7	2	16d duplex	2	10d	4280	4280	4280	5, F30,
5-1/8 x glulam	MPH525	---	12	5-1/4	specify	7	2	16d duplex	2	10d	4280	4280	4280	R5

- 1) Masonry compressive strength shall be minimum 1500 psi.
- 2) Duplex nails are No. 8 wire gauge (0.162" diameter) and 3-1/2" long, double headed nails and shall be installed in grouted cells in accordance to manufacturer's installation specifications.
- 3) Minimum nail embedment shall be 1-1/2" for 10d nails.

## Specialty Options Chart – refer to Specialty Options pages 194, 196 to 197 for additional details.

Option	Skewed <sup>1</sup>	Sloped Seat <sup>2</sup>	Sloped / Skewed <sup>1,2</sup>	Top Flange Offset	
Range	1° to 60°	1° to 45°	See Sloped Seat and Skewed	-- --	
Allowable Loads	100% of table load	100% of table load	100% of table load	Hanger Width 3-1/2" or less 3-9/16" to 5-1/2" 5-9/16" to 7-1/2"	% of table load: 60% 75% 85%
Ordering	Add SK, angle required, and right (R) or left (L), to product number. Ex. MPH210-SK45R	Add SL, slope required, and up (U) or down (D), to product number. Ex. MPH210-SL30D	See Sloped Seat and Skewed. Ex. MPH210-SK45RSL30D	Add OS, and right (R) or left (L), to product number. Ex. MPH210-OSL	

- 1) Skewed hangers with skews greater than 15° may have all joist nailing on outside flange.
- 2) Sloped or sloped / skewed hangers with slopes greater than 15° may have additional joist nails.

## UNIVERSAL MASONRY HANGERS – UMH SERIES

A versatile solution for hanging beams from masonry walls. Face mount design allows hanger to be used with beam heights from 16" to 24". Available in a variety of widths for solid sawn, glulam, or engineered lumber beams.

**Materials:** 1/4" steel  
**Finish:** USP primer  
**Codes:** Dade County, FL 04-1122.03, FL5631

### Installation:

- Use all specified fasteners. See Product Notes, page 11.
- Fully grouted and reinforced concrete block or cast-in-place concrete with a minimum of (1) #5 rebar continuous to footing with standard hook at bolt locations.
- Minimum joist bearing length is 3 1/2".

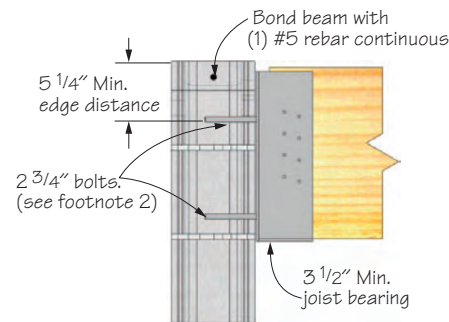

**Typical UMH installation**

USP Stock No.	Ref. No.	Steel Gauge	W	Fastener Schedule				DF-L / SP Allowable Loads (Lbs.)								Code Ref.
				Header <sup>2,3</sup>		Joist <sup>4</sup>		Masonry - 2500 psi				Cast in Place Concrete - 3000 psi				
				Qty	Bolt Dia.	Qty	Type	Floor	Roof	Uplift <sup>1</sup>	Floor	Roof	Uplift <sup>1</sup>			
UMH358	MBHU3.56/16KT, MBHU3.56/18KT	3	3-5/8	2	3/4	16	16d	3550	3550	3550	3550	6380	6380	6380	4815	F25, D1
UMH458	---		4-5/8													
UMH538	---		5-3/8													
UMH558	MBHU5.50/16KT, MBHU5.50/18KT		5-5/8													
UMH718	---		7-1/8													

- 1) Uplift loads have been increased 60% for wind or seismic loads; no further increase shall be permitted.
  - 2) Fasten UMH hanger to concrete structure with two 3/4" dia. Powers Fasteners Wedge-Bolts® or equal with 5" minimum embedment. Bolts shall be installed in masonry with grouted cells in accordance with manufacturer's installation specifications.
  - 3) Bolts must conform to ASTM A 307 or better.
  - 4) Minimum nail embedment shall be 1-5/8" for 16d nails.
- New products or updated product information are designated in bold font.

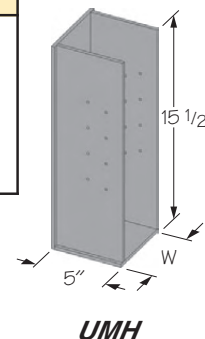

**UMH**

**NFM** – Standard design.

**NFM\_U** – High uplift design.

**Materials:** See chart

**Finish:** USP primer

**Codes:** FL578, Dade County, FL 07-1003.10

**Installation:**

- Use all specified fasteners. See Product Notes, page 11.
- Designed for both concrete walls and grout-filled reinforced CMU walls.

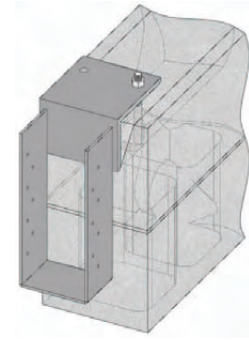

**Typical NFM45 installation**

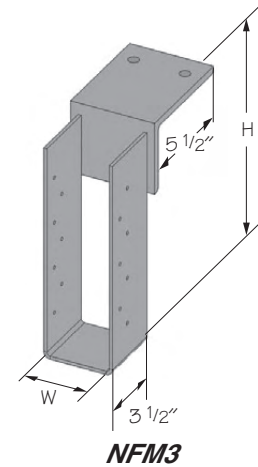

**NFM3**

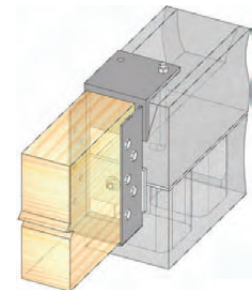

**Typical NFM45U installation**

USP Stock No.	Ref. No.	Steel Gauge		Dimensions		Fastener Schedule				Allowable Loads (Lbs.) <sup>1,2</sup>				Code Ref.
		Top Flange	U-Strap	W	H	Header <sup>3,4</sup>		Joist <sup>5,6</sup>		DF-L / SP				
						Qty	Type	Qty	Type	Floor	Roof		Uplift	
NFM3X8	---	3/8	7	3-1/8	7-1/4	1	1/2" J-Bolt	10	10d	7130	7130	7130	1720	F9, D8
NFM3X10	---	3/8	7	3-1/8	9-1/4	1	1/2" J-Bolt	12	10d	7130	7130	7130	1720	F9, D8
NFM3X12	---	3/8	7	3-1/8	11-1/4	1	1/2" J-Bolt	14	10d	7130	7130	7130	1720	F9, D8
NFM3	---	3/8	7	3-3/8	11-3/4	1	1/2" J-Bolt	14	10d	7510	7510	7510	1720	F9, D8
NFM35X8	---	3/8	7	3-5/8	7-1/4	1	1/2" J-Bolt	10	10d	7510	7510	7510	1720	F9, D8
NFM35X10	---	3/8	7	3-5/8	9-1/4	1	1/2" J-Bolt	12	10d	7510	7510	7510	1720	F9, D8
NFM35X12	---	3/8	7	3-5/8	11-1/4	1	1/2" J-Bolt	14	10d	7510	7510	7510	1720	F9, D8
NFM35X1178	---	3/8	7	3-5/8	11-7/8	1	1/2" J-Bolt	14	10d	7510	7510	7510	1720	F9, D8
NFM35X16	---	3/8	7	3-5/8	16	1	1/2" J-Bolt	14	10d	7510	7510	7510	1720	F9, D8
NFM35X18	---	3/8	7	3-5/8	18	1	1/2" J-Bolt	14	10d	7510	7510	7510	1720	F9, D8
NFM6X1178	---	3/8	7	5-5/8	11-7/8	1	1/2" J-Bolt	14	10d	7510	7510	7510	1720	F9, D8
NFM6X16	---	3/8	7	5-5/8	16	1	1/2" J-Bolt	14	10d	7510	7510	7510	1720	F9, D8
NFM6X18	---	3/8	7	5-5/8	18	1	1/2" J-Bolt	14	10d	7510	7510	7510	1720	F9, D8
NFM3X10U	MBHA3.12/9.25	3/8	7	3-1/8	9-1/4	1	1/2" J-Bolt	5	1/2	7130	7130	7130	3165	F9, D8
NFM3X12U	MBHA3.12/11.25	3/8	7	3-1/8	11-1/4	1	1/2" J-Bolt	5	1/2	7130	7130	7130	3165	F9, D8
NFM35X10U	MBHA3.56/9.25	3/8	7	3-5/8	9-1/4	1	1/2" J-Bolt	5	1/2	7130	7130	7130	3165	F9, D8
NFM35X12U	MBHA3.56/11.25	3/8	7	3-5/8	11-1/4	1	1/2" J-Bolt	5	1/2	7130	7130	7130	3165	F9, D8
NFM35X1178U	MBHA3.56/11.88	3/8	7	3-5/8	11-7/8	1	1/2" J-Bolt	5	1/2	7130	7130	7130	3165	F9, D8
NFM35X14U	MBHA3.56/14	3/8	7	3-5/8	14	1	1/2" J-Bolt	5	1/2	7130	7130	7130	3165	130
NFM35X16U	MBHA3.56/16	3/8	7	3-5/8	16	1	1/2" J-Bolt	5	1/2	7130	7130	7130	3165	F9, D8
NFM35X18U	MBHA3.56/18	3/8	7	3-5/8	18	1	1/2" J-Bolt	5	1/2	7130	7130	7130	3165	F9, D8
NFM6X10U	MBHA5.50/9.25	3/8	7	5-5/8	9-1/4	1	1/2" J-Bolt	5	1/2	7130	7130	7130	3165	130
NFM6X12U	MBHA5.50/11.25	3/8	7	5-5/8	11-1/4	1	1/2" J-Bolt	5	1/2	10310	10310	10310	3070	130
NFM6X1178U	MBHA5.50/11.88	3/8	7	5-5/8	11-7/8	1	1/2" J-Bolt	5	1/2	10310	10310	10310	3070	F9, D8
NFM6X14U	MBHA5.50/14	3/8	7	5-5/8	14	1	1/2" J-Bolt	5	1/2	10310	10310	10310	3070	130
NFM6X16U	MBHA5.50/16	3/8	7	5-5/8	16	1	1/2" J-Bolt	5	1/2	10310	10310	10310	3070	F9, D8
NFM6X18U	MBHA5.50/18	3/8	7	5-5/8	18	1	1/2" J-Bolt	5	1/2	10310	10310	10310	3070	F9, D8

- 1) Allowable loads are based on 2500 psi concrete or masonry.
- 2) Design loads are governed by test ultimate loads with a safety factor of three.
- 3) J-Bolt shall be cast-in-place and have a minimum 6" embedment and not less than 4" from the edge of concrete.
- 4) In addition to the J-Bolt, "U" models also require a 3/4" dia. ITW Ramset/Redhead Dyna Bolt Sleeve anchor or equal with minimum 5" embedment depth installed in the face. Bolt shall be installed in accordance with installation specifications provided by ITW Ramset.
- 5) Bolts shall conform to ASTM A 307 or better.
- 6) Minimum nail embedment shall be 1-1/2" for 10d nails.

**NFM Specialty Options Chart – refer to Specialty Options pages 194, 196 to 197 for additional details.**

Option	Skewed <sup>1,2</sup>
Range	1° to 45°
Allowable Loads	100% of table load
Ordering	Add SK, angle required, and right (R) or left (L), to product number. Ex. NFM3-SK45R

- 1) Skewed hangers with skews greater than 15° may have all joist nailing on outside flange.
- 2) Skewed hangers with skews greater than 15° require the joist end to be bevel cut.

