

ADHESIVE & UNDERCUT ANCHORING SYSTEMS..... PAGES 22-24

- **DUC Series**
Ductile Undercut Anchors.
- **CIA-EA**
High strength epoxy acrylate.
- **CIA-GEL 7000**
High strength epoxy.

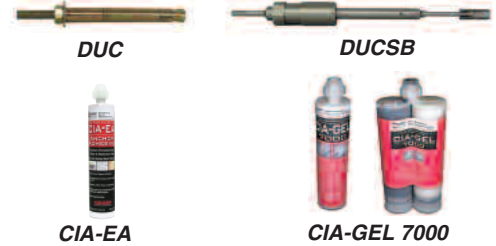

ANCHOR BOLT STABBER..... PAGE 25

- **ABS12**
Anchor bolt stabber for placement in wet concrete.



THREADED RODS PAGE 25

- **THR Series**
Threaded Rod



ANCHOR BOLTS PAGES 25-27

- **STB & STBL Series**
USP anchor bolts designed for higher capacity applications.
- **AB Series**
USP anchor bolts designed for general capacity applications.



CONCRETE FORM TIES & WEDGE PAGE 27

- **FT Series**
Low foundation wall tie.
- **WG**
Wedge for FT tie.

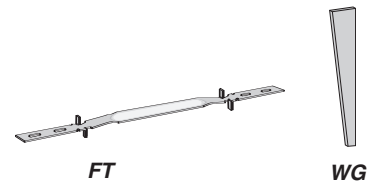

FOUNDATION ANCHORS PAGES 28-29

- **ST Series**
Embedded mudsill anchors.
- **FA3**
Embedded mudsill and stud anchors.
- **SFA & SFJA Series**
Bolted mudsill anchors for retrofit applications.

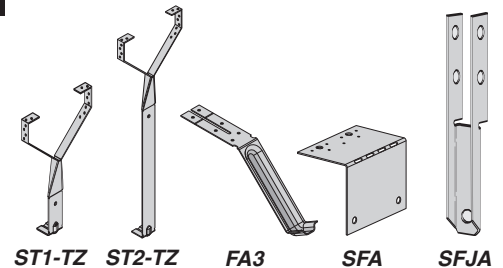

LAMINATED BEAM SEATS PAGE 30

- **KGLB, KGLBT, & KHGLB Series**
Seats for beams bearing on concrete or masonry.

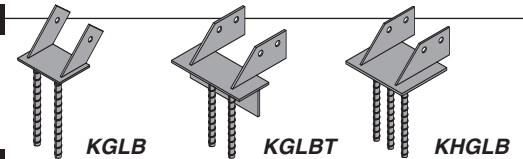

FLOOR GIRDER HANGERS..... PAGE 31

- **KGH Series**
Secures girder beam to foundation wall.

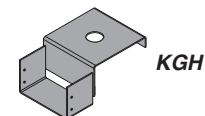

RETRO PLATE PAGE 31

- **RP6**
Oversized plate to distribute forces on masonry surface.



© Copyright 2009 USP Structural Connectors®

Concrete & Masonry

Mechanical anchor expanded into a hole that has been undercut at the bottom using an undercutting drill bit creating a true bearing type anchor that performs like a cast-in-place headed anchor. Load is transferred into the concrete through bearing, not friction like traditional expansion anchors. Excellent performance in seismic and dynamic loading conditions. Meets ACI 318-05 Appendix D (2006 IBC) requirements as a code anchor, including seismic loading, tension zone, and cracked concrete provisions.

Rod Materials: ASTM A36 (L Series), A193 Grade B7 (H Series), or AISI 316 Stainless Studs

Anchor Body Materials: ASTM A 513 Type 5, or AISI 316 Stainless

Codes: ESR-1970, L.A. City RR 25753



DUC Undercut Anchor



DUC UCB Undercut Drill Bit

Installation:

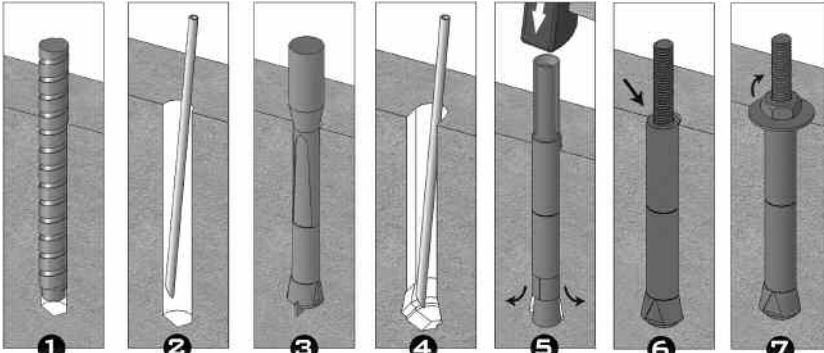

1 Drill the hole to proper depth and diameter per specifications using rotohammer and stop drill.

2 Clean the hole using a blow-out bulb or compressed air.

3 Insert the undercut bit and start the rotohammer. Undercutting is complete when the stopper sleeve is fully compressed (gap closed).

4 Clean the hole again using a blow-out bulb or compressed air.

5 Insert anchor into hole. Place setting sleeve over anchor and drive the expansion sleeve over the expansion coupling.

6 Verify that the setting mark is visible on the threaded rod above the sleeve.

7 Apply proper torque.

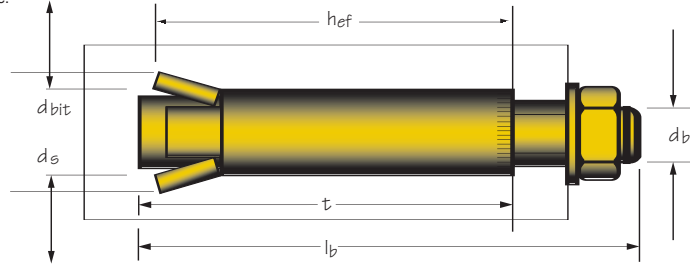

Tension and Shear Capacities for DUC Anchors in $f'c \geq 2,500$ psi concrete

USP Stock No.	Stud Dia. D_s	Drill Hole Dia. D_{bit}	Drill Hole Depth t	Effective Embedment h_{ef}	Overall Length, l	Sleeve length l_s	Allowable Tensile Capacity, N_s	Allowable Shear Capacity V_s	Code Ref.
DUC38-275L	3/8	5/8	3-1/8	2-3/4	6	2-3/4	2087	1043	7, R10
DUC38-275LT			4-3/8	4	7-1/2	4-1/2			
DUC38-400H						4			
DUC38-400HT			5-3/4						
DUC12-400L	1/2	3/4	4-3/8	4	7-1/2	4	3821	1909	
DUC12-400LT			5-3/8	5	8-1/2	5-3/4			
DUC12-500H						5			
DUC12-500HT			6-3/4						
DUC12-675H	5/8	1	7-1/8	6-3/4	10-1/4	6-3/4	8235	4111	
DUC12-675HT			8-1/8	7-1/2	11-3/8	8-1/2			
DUC58-450L						9-1/4			
DUC58-450LT			10-3/4						
DUC58-750H	3/4	1-1/8	5-1/8	4-1/2	8-3/8	7-1/2	6086	3047	
DUC58-750HT			8-1/8	7-1/2	11-3/8	9-1/4			
DUC58-900H						9			
DUC58-900HT			10-3/4						
DUC34-500L	3/4	1-1/8	5-5/8	5	9	5	9007	4497	
DUC34-500LT			10-5/8	10	14	6-3/4			
DUC34-1000H						10			
DUC34-1000HT			11-3/4						

1) Allowable tensile and shear capacities are for anchors installed at standard edge distance and spacing in uncracked concrete in accordance with the 2003 and 2006 IBC (ACI 318-02 and 318-05). For cracked concrete capacities, see the USP Anchoring Systems Design Guide.

CIA-EA – For use in anchoring threaded rod and rebar into normal and lightweight concrete, stemwalls, concrete block, reinforced brick and unreinforced masonry. Bonds to most construction materials. **For use in substrate temperatures above 5° F.**

Materials: 2-component, 100% solids, all weather, moisture insensitive, non-sag, non-shrink, solvent free, high strength epoxy acrylate.

Codes: ESR-1702,
L.A. City RR 25113, FL 4928

Installation:

- Drill hole in concrete or masonry to specified depth and diameter.
- Clean hole completely using compressed air and nylon brush. Dust and debris left in the hole will reduce the holding capacity of the anchor.
- Remove cartridge cap and insert cartridge into dispensing tool. Dispense a small amount of adhesive off to the side to equalize the cartridge.
- Place mixing nozzle (and nut if required) onto cartridge and tighten. Dispense a small amount of adhesive off to the side to ensure proper mixing. Do not use adhesive that is not mixed properly.
- Inject adhesive into the bottom of the hole to avoid air pockets. Fill approximately one half to two thirds full.
- Insert rod into hole while rotating one to two revolutions until the rod contacts the bottom of the hole.



10 oz.
ACR-10
CIA-EA

Shear Capacities for Threaded Rod Installed at a Close Edge Distance for Sill Plates

Rod Diameter (in)	Embed. Depth (in)	Min. Edge Distance (in)	Avg. Ult. Capacity (Lbs.)	Allowable Shear Capacity (Lbs.) ¹	
				100%	133%
3/8	3-3/8	1-3/4	3160	790	1050
1/2	4-1/2	1-3/4	4160	1040	1385
5/8	4-1/2	1-3/4	4160	1040	1385

1) Shear load applied parallel to free edge.

Tension and Shear Capacities for Threaded Rod Installed in Normal Weight Concrete

Rod Diameter (in)	Drill Bit Diameter (in)	Embed. Depth (in)	Tensile Capacity based on Concrete Strength (Lbs.)		Shear Capacity based on Concrete Strength (Lbs.)		Allowable Steel Capacity for A307 (AISI 1018) rod		Code Ref.
			f _c ≥ 2500 psi		f _c ≥ 2500 psi		Tensile (Lbs.)	Shear (Lbs.)	
			CIA-EA		CIA-EA				
			Avg. Ult.	Avg. Allow.	Avg. Ult.	Avg. Allow.			
3/8	7/16	3-3/8	6800	1700	5940	1485	2185	1125	F24
1/2	9/16	4-1/2	11580	2895	10240	2560	3885	2000	
5/8	11/16	5-5/8	23380	5845	17640	4410	6070	3125	
3/4	13/16	6-3/4	28460	7115	25300	6325	8740	4500	
7/8	15/16	7-7/8	28460	7115	25300	6325	11900	6130	
1	1-1/8	9	44200	11050	40980	10245	15540	8000	

Cure Times

Substrate Temperature F	CIA-EA	
	Bolt Up Time	Full Cure Time
5° - 10°	12 hrs	36 hrs
11° - 20°	9 hrs	30 hrs
21° - 30°	6 hrs	24 hrs
31° - 40°	4 hrs	12 hrs
41° - 50°	2 hrs	6 hrs
51° - 60°	15 min	70 min
61° - 70°	15 min	60 min
71° - 80°	10 min	30 min
80° - 90°	4 min	25 min

- 1) Allowable load must be the lesser of bond or steel strength.
- 2) The tabulated values are for anchors installed at specified spacing (s) and edge (c) distances. Spacing and edge distances may be reduced, reference the Anchoring Systems Technical Guide for details. Linear interpolation may be used for intermediate spacing and edge distances.
- 3) The tabulated values are for anchors installed in concrete having the designated compressive strength or higher at the time of installation.
- 4) CIA anchors experience a reduction in tensile capacity with increased ambient temperatures. Temperature load factors must be applied when the anchors are installed in locations where the concrete temperatures may exceed 105°F.
- 5) The anchors cannot be used to resist pullout forces in overhead and wall installations, unless proper consideration is given to fire conditions.
- 6) Allowable load based on bond strength may be interpolated for compressive strengths between f_c = 2000 psi and f_c = 4000 psi.
- 7) Allowable loads may be increased by 33-1/3% for short term loading due to earthquakes or wind for Allowable Stress Design.
- 8) Bond strength values are based on a safety factor of 4.0.



Anchor to Connector Guide

For Applications with USP Holdowns refer to USP Anchor to Connector Guide (USP1017) or visit www.uspconnectors.com

© Copyright 2009 USP Structural Connectors®

Concrete & Masonry

CIA-GEL 7000 – For use in anchoring threaded rod and rebar into normal and lightweight concrete, stemwalls, concrete block, reinforced brick and unreinforced masonry (URM/UMB). Bonds to most construction materials. **For use in substrate temperatures above 35° F.**

Materials: 2-component, 100% solids, 1 to 1 ratio, moisture insensitive, non-sag, non-shrink, solvent free, high strength epoxy.

Codes: ESR-1702, FL 4928,
L.A. City RR 25113 & RR 25029

Installation:

- Drill hole in concrete or masonry to specified depth and diameter.
- Clean hole completely using compressed air and nylon brush. Dust and debris left in the hole will reduce the holding capacity of the anchor.
- Remove cartridge cap and insert cartridge into dispensing tool. Dispense a small amount of adhesive off to the side to equalize the cartridge.
- Place mixing nozzle (and nut if required) onto cartridge and tighten. Dispense a small amount of adhesive off to the side to ensure proper mixing. Do not use adhesive that is not mixed properly.
- Inject adhesive into the bottom of the hole to avoid air pockets. Fill approximately one half to two thirds full.
- Insert rod into hole while rotating one to two revolutions until the rod contacts the bottom of the hole.

Tension Capacities for Threaded Rod Installed in Concrete Stemwall Foundations

Rod Diameter (in)	Embed. Depth (in)	Min. Wall Width (in)	Min. Edge Distance (in)	Min. End Distance (in)	Avg. Ult. Capacity (Lbs.)	Allowable Tensile Capacity (Lbs.)	
						100%	133%
5/8	9	5	1-3/4	5	11120	2780	3705
				12	13840	3460	4615
7/8	12-1/4	8	2-3/4	5	19040	4760	6346
				12	23640	5910	7880
7/8	18	12	1-3/4	10	35400	8850	11800
				15	41520	10380	13840

Shear Capacities for Threaded Rod Installed at a Close Edge Distance for Sill Plates

Rod Diameter (in)	Embed. Depth (in)	Min. Edge Distance (in)	Avg. Ult. Capacity (Lbs.)	Allowable Shear Capacity (Lbs.) ¹	
				100%	133%
1/2	4-1/2	1-3/4	5792	1448	1926
5/8	5-3/4	1-3/4	10800	2700	3600

1) Shear load applied parallel to free edge.

Tension and Shear Capacities for Threaded Rod Installed in Normal Weight Concrete

Rod Diameter (in)	Drill Bit Diameter (in)	Embed. Depth (in)	Tensile Capacity based on Concrete Strength (Lbs.)		Shear Capacity based on Concrete Strength (Lbs.)		Allowable Steel Capacity for A307 (AISI 1018) rod		Code Ref.
			f'c ≥ 2500 psi		f'c ≥ 2500 psi		Tensile (Lbs.)	Shear (Lbs.)	
			CIA-GEL 7000		CIA-GEL 7000				
			Avg. Ult.	Avg. Allow.	Avg. Ult.	Avg. Allow.			
3/8	1/2	1-7/8	4760	1190	---	---	2185	1125	4, F24, R2
		3-3/8	8600	2150	5880	1470			
1/2	5/8	2-1/2	7760	1940	---	---	3885	2000	
		4-1/2	13980	3495	14220	3555			
5/8	3/4	3-1/8	10400	2600	---	---	6070	3125	
		5-5/8	21600	5400	19060	4765			
3/4	7/8	3-3/4	15660	3915	---	---	8740	4500	
		6-3/4	26740	6685	27620	6905			
7/8	1	7-7/8	33968	8492	34748	8687	11900	6130	
1	1-1/4	9	49320	12330	44720	11180	15540	8000	

Cure Times

Substrate Temperature F	CIA-GEL 7000	
	Bolt Up Time	Full Cure Time
41° - 50°	12 hrs	72 hrs
51° - 60°	8 hrs	48 hrs
61° - 70°	6 hrs	36 hrs
71° - 80°	4 hrs	24 hrs
80° - 90°	4 hrs	24 hrs

- 1) Allowable load must be the lesser of bond or steel strength.
- 2) The tabulated values are for anchors installed at specified spacing (s) and edge (c) distances. Spacing and edge distances may be reduced, reference the Anchoring Systems Technical Guide and/or ICC-ES ESR-1702 for details. Linear interpolation may be used for intermediate spacing and edge distances.
- 3) The tabulated values are for anchors installed in concrete having the designated compressive strength or higher at the time of installation.
- 4) CIA anchors experience a reduction in tensile capacity with increased ambient temperatures. Temperature load factors must be applied when the anchors are installed in locations where the concrete temperatures may exceed 105°F.
- 5) The anchors cannot be used to resist pullout forces in overhead and wall installations, unless proper consideration is given to fire conditions. Reference ICC-ES ESR-1702 for more information.
- 6) Allowable load based on bond strength may be interpolated for compressive strengths between f'c = 2000 psi and f'c = 4000 psi.
- 7) Allowable loads may be increased by 33-1/3% for short term loading due to earthquakes or wind for Allowable Stress Design.
- 8) Bond strength values are based on a safety factor of 4.0.



10 oz.
GEL-10

22 oz.
GEL-22

CIA-GEL 7000

ANCHOR BOLT STABBER (BOLT RITE™) – ABS12



For accurate placement of 1/2" anchor bolts in wet concrete. The outstanding legs are different lengths, with the shorter leg centering the anchor bolt in a 2 x 4 sill plate and the longer leg centering the anchor bolt in a 2 x 6 sill plate.

Materials: Composite Plastic
Finish: See chart
Patents: Pending

Installation:

- Slide ABS over anchor bolt and screw on cap.
- Place bolt in wet concrete using guides for proper edge distance.

USP Stock No. ¹	Ref. No.	Bolt Dia.	Color	Code Ref.
ABS12	---	1/2	orange	120

1) Anchor bolt caps are included with product.

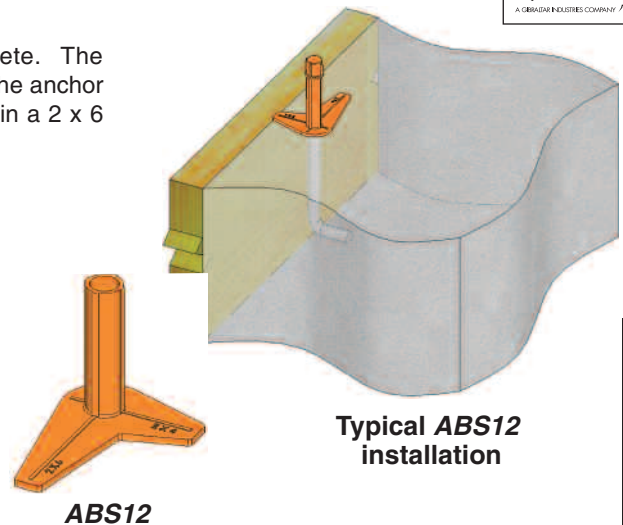

Typical ABS12 installation

ABS12

THREADED RODS – THR SERIES

Materials: A36 Steel
Finish: Hot-dip galvanizing

USP Stock No.	Ref. No.	Bolt Dia.	L	Code Ref.
THR125-HDG	---	1/2	5	130
THR126-HDG	---	1/2	6	
THR128-HDG	---	1/2	8	
THR5816-HDG	---	5/8	16	

New products or updated product information are designated in red.



THR

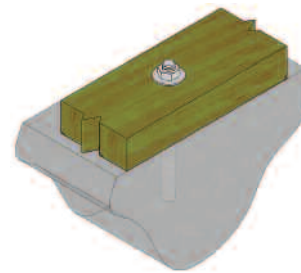

Typical THR installation

ANCHOR BOLTS – STB & STBL SERIES

Embossed ends provide guides for embedment angle and depth. An embedment line is embossed on the shaft for easy installation. Features rolled threads for high tensile strength.

STB – For monolithic slabs and double pour concrete installations.

STBL – Designed for use with 3x sill plates. Excellent choice for use with taller holdown washers like those in the PHD series.

Materials: ASTM A 36 steel, also conforms to ASTM F 1554 and ASTM A 307 requirements for bolts

Finish: None
Codes: ER-5321

Installation:

- Select appropriate STB or STBL Anchor Bolt.
- Use concrete with minimum compressive strength of 2,500 psi at 28 days.
- Minimum center-to-center spacing between bolts is 2(E) for anchors acting simultaneously in tension.
- Match embedment depth with embedment line on the STB or STBL shaft.
- The STB or STBL does not need to be tied to the rebar.
- Nuts and washers are not included.
- Use Bolt-Rite™ products to hold anchor bolt in place during installation.

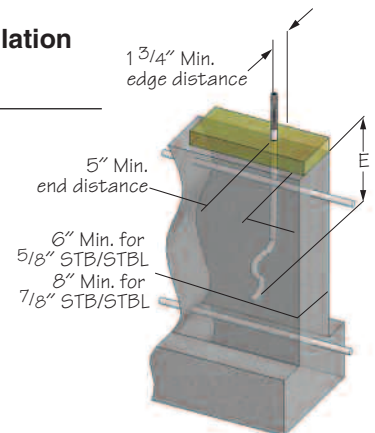

Typical STB/STBL mono pour installation

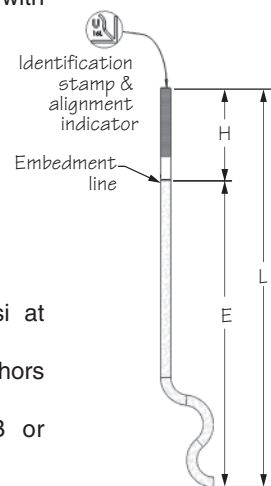

STB/STBL

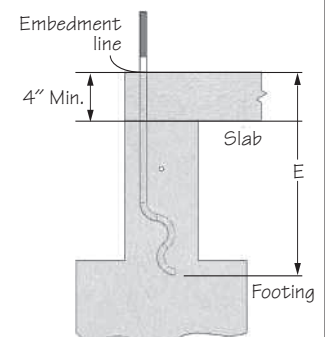

Typical double pour installation

continued on next page

Monolithic or Double Pour Foundations – Prior to pour, install the STB or STBL in an upright position and at a 45° angle to the wall. Install one horizontal #4 rebar at a depth of 4" (minimum). (See illustrations.)

Concrete Block Applications – Prior to cell pour, install the STB or STBL in an upright position and at a 45° angle to the wall. (See illustrations.) Use the embossed angle guide on the end of the STB or STBL shaft as a guide. Install one horizontal #4 rebar at a depth of 4" and one vertical #4 rebar maximum 48" o.c. spacing. Fill all cells with concrete having a minimum 2,000 psi compressive strength.

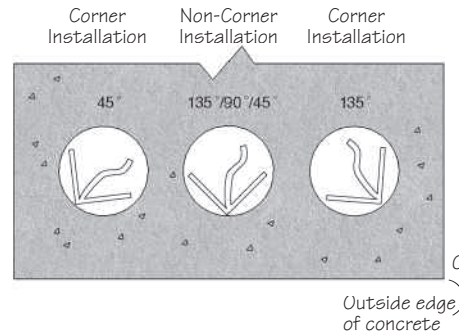

Plan view of STB/STBL placement in concrete stemwall

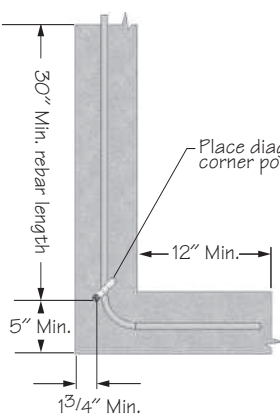

Plan View of Corner installation

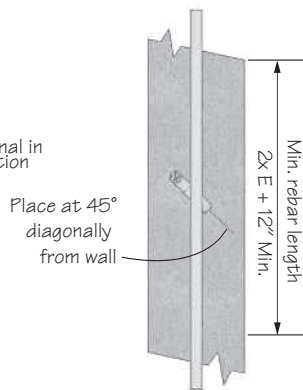

Plan View of Continuous stem wall installation

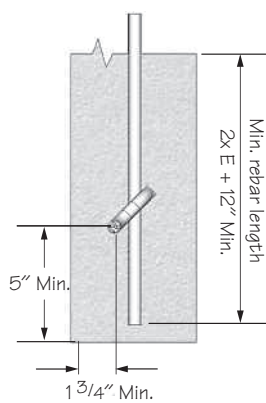

Plan View of End wall installation

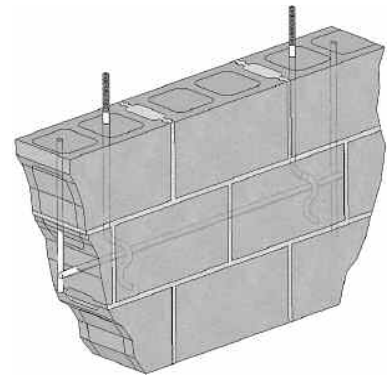

Typical STB/STBL concrete block installation

Anchor Bolt Selection table

USP Stock No.	Ref. No.	2x, 3x, (2) 2x Sill Plates ¹	
		Mono Pour	Double Pour
PHD2	HDU2-SDS2.5 HDU4-SDS2.5	STB16 STBL16	STB20 STBL20
TDX2	HD2A		
LTS20B	LTT20B		
HTT16	HTT16		
PHD5	HDU5-SDS2.5	STB20 STBL20	STB24 STBL24
TDX5*	HD5A		
HTT22	HTT22	STB24 STBL24	STB24 STBL24
PHD6	HDU8-SDS2.5	STB28 STBL28	STB34 STBL34
PHD8	---		
UPHD8	---		
TDX6	HD6A		
TD8	HD8A		
TDX10	HD10A		

Recommend installation of washer under nut of anchor bolt.
) STBL model are recommended for use with PHD and UPHD8 holdowns on (2) 2x and 3x sill plates.

USP Stock No.	Ref. No.	Bolt Dia.	Dimensions			Allowable Tension Load ^{1,2,3}				Code Ref.
			L	H	Min. Embed. (E)	Concrete ⁵		Concrete Block ⁸		
						Minimum End Distance ⁶				
						5" from end	24" from end	5" from end	11" or > from end	
Wind / Seismic	Wind / Seismic	Wind / Seismic	Wind / Seismic							
STB16	SSTB16	5/8	17-13/16	5	12-13/16	5215	5215	1850	4315	L4
STB20	SSTB20	5/8	21-13/16	5	16-13/16	5215	5215	1850	4315	
STB24	SSTB24	5/8	25-13/16	5	20-13/16	5215	5215	1850	4315	
STB28	SSTB28	7/8	31	5	26	9335	10425	---	---	
STB34	SSTB34	7/8	36	6	30	9335	10425	---	---	
STB36	SSTB36	7/8	38	8	30	9335	10425	---	---	
STBL16	SSTB16L	5/8	19-9/16	6-3/4	12-13/16	5215	5215	1850	4315	
STBL20	SSTB20L	5/8	23-9/16	6-3/4	16-13/16	5215	5215	1850	4315	
STBL24	SSTB24L	5/8	27-9/16	6-3/4	20-13/16	5215	5215	1850	4315	
STBL28	SSTB28L	7/8	32-3/4	6-3/4	26	9335	10425	---	---	
STBL34	---	7/8	36-3/4	6-3/4	30	9335	10425	---	---	

- 1) Design loads are based on the average ultimate, from a series of five tests, with a safety factor of three.
- 2) Loads may not be increased for short term loading. Loads apply to wind and seismic loading per 1997 U.B.C.
- 3) Minimum center to center spacing between bolts is 2(E) for anchors acting in tension.
- 4) Minimum edge distance is 1-3/4".
- 5) Concrete stemwall shall be a minimum of 6" thick for 5/8" anchor bolts and 8" for 7/8" anchor bolts.
- 6) End distance shall be no less than 5".
- 7) Connection is limited by lowest of bolt or holdown capacity.
- 8) Concrete block shall be minimum 10" block.

Materials: Bolt: ASTM F 1554,
Nut: ASTM A 563,
Washers: ASTM F 844
Finish: Hot-dip galvanized

The codes specify a minimum diameter and embedment into masonry or concrete for anchor bolts used in foundation plates or sills.
IRC R403.1.6, IBC 2308.6, 2308.12.9.

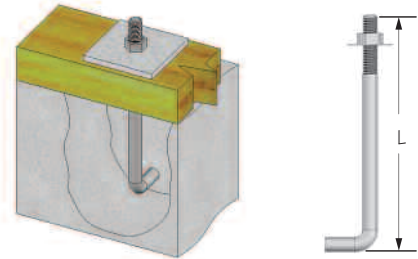

Typical AB128-HDG installation AB128-HDG

Installation:

- Select appropriate AB Anchor Bolt.
- Use concrete with minimum compressive strength of 2,000 psi at 28 days.
- Nuts and washers are included.
- Anchor bolts intended for use to satisfy code prescribed anchoring of mudsill plates, and shall be installed as defined in the code.
- Allowable loads shall be derived in accordance with the code.

USP Stock No.	Ref. No.	Bolt Dia.	L	Code Ref.
AB126-HDG	LBOLT50600HDG	1/2	6	100
AB128-HDG	LBOLT50800HDG	1/2	8	
AB1212-HDG	LBOLT50120HDG	1/2	12	

© Copyright 2009 USP Structural Connectors®

Concrete & Masonry

CONCRETE FORM TIES & WEDGE – FT SERIES & WG

FT – Connect 1x and 2x nominal form lumber in low foundation walls up to 4 feet high.

WG – V-shaped wedge assures rigidity and consistent form spacing.

Materials: FT – 18 gauge, WG – 14 gauge
Finish: G90 galvanizing

Installation:

- Use the Spacing Guide chart to determine spacing between FT units. Each level in chart assumes 12" form boards. Wall thickness from 6" to 12".
- Install with "V" facing up.
- Use (2) WG wedges for each tie. Insert wedge into inside slots for 1x nominal forms and outside slots for 2x nominal forms.
- No walers or stiff-backs are used.
- Vertical ties to keep forms from separating are not included.
- Form deflection may be substantial. Check deflection, if it is critical, and move ties to compensate.
- Forming lumber is assumed to have fb of 1,000 psi.
- **Not recommended for pours greater than 4 feet in height.**

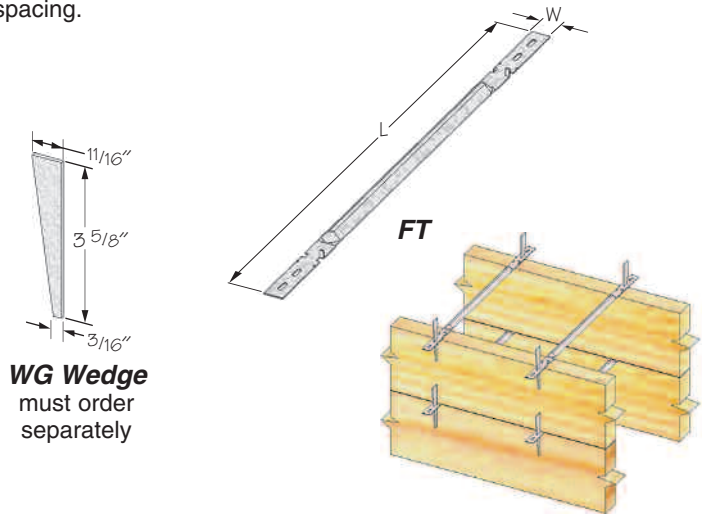

WG Wedge must order separately

Typical FT/WG installation

Spacing Guide chart

Concrete Lift Height	Level 1		Level 2		Level 3		Level 4	
	1x	2x	1x	2x	1x	2x	1x	2x
12" or Less	2' 6"	4' 0"	---	---	---	---	---	---
12" - 24"	1' 6"	3' 0"	2' 6"	4' 0"	---	---	---	---
24" - 36"	1' 0"	2' 0"	1' 6"	3' 0"	2' 6"	4' 0"	---	---
36" - 48"	0' 9"	1' 6"	1' 0"	2' 0"	1' 6"	3' 0"	2' 6"	4' 0"

1) Factor of safety against tensile failure of tie is 1.5 or more.

USP Stock No.	Ref. No.	Steel Gauge	Dimensions		Wedge Qty	Footing Width or Wall Thickness	Code Ref.
			W	L			
FT6	WT6	18	5/8	10-5/8	2	6	120
FT8	WT8	18	5/8	12-5/8	2	8	
FT10	WT10	18	5/8	14-5/8	2	10	
FT12	WT12	18	5/8	16-5/8	2	12	
FT14	---	18	5/8	19	2	14	
FT16	---	18	5/8	21	2	16	
WG	W1	14	11/16	3-5/8	---	---	120

1) May be used with either 3/4" or 1-1/2" forming materials.
2) Breaking strength is approximately 775 pounds. Space as necessary to prevent form blow-out.

FA3 – For installation into concrete slabs. The FA3 features a split flange for nailing to both mudsill and stud for greater framing versatility.

ST1-TZ – For installation into concrete slab or poured stemwalls. The ST1-TZ features a prebent base flange to assure proper anchoring into concrete. **For concrete/masonry installations, refer to the FA & ST Foundation Anchors Technical Bulletin.**

ST2-TZ – For installation into concrete slab, poured stemwalls or concrete/masonry. The ST2-TZ features a prebent base flange to assure proper anchoring into concrete. **Do not use in red clay brick.**

Materials: See chart

Finish: G90 galvanizing

Options: FA3 is available in Triple Zinc.

To order, add **TZ** to end of stock number, as in **FA3-TZ**.

Codes: NER 530, FL822

Installation:

- Use all specified fasteners. See Product Notes, page 10.
- Use a minimum of two anchors per mudsill. An anchor should always be within 12" of the end of each mudsill section. Follow spacing guidelines in chart.
- Do not rely on these anchors to secure concrete sections together between cold joints.
- For **FA3** insert into wet concrete (minimum strength of 2,000 psi). Place mudsill after concrete cures. Secure flanges to sill (and stud, if applicable), bending flanges as needed to achieve a tight fit. Fasten as directed in chart.
- For **ST1-TZ** and **ST2-TZ** spread sill flanges to mudsill width prior to insertion into wet concrete (minimum strength of 2,000 psi). Alternate installation is possible by inserting unbent flanges through 3/4" center hole predrilled in mudsill. Foundation anchors may also be attached to mudsill and then inserted into wet concrete. When installing ST2-TZ into concrete block, fill cells with grout with a minimum strength of 2,000 psi. Concrete block edges may need to be beveled to facilitate installation.
- For additional installation details and information on mudsill anchors refer to **ST** Foundation Anchors Technical Bulletin.
- **ST2-TZ** in masonry construction shall be installed in the core of the block and grouted with concrete grout designed for that purpose. In no case, shall they be installed in a mortar joint.

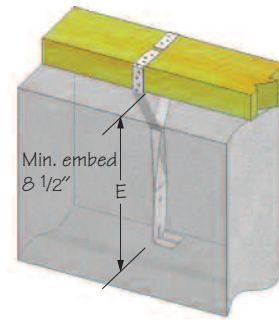

**Typical
ST1-TZ
installation
in concrete**

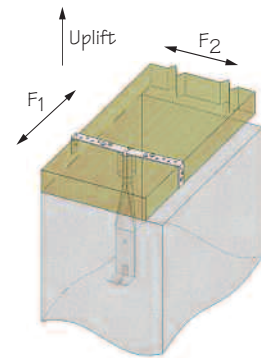

**Alternate
ST1-TZ
installation with
3/4" center hole**

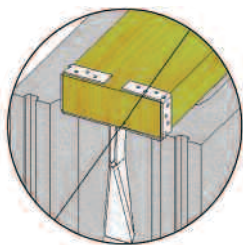

**DO NOT install
ST1-TZ and ST2-TZ
without pre-bending
sill flanges in "Y"
configuration**

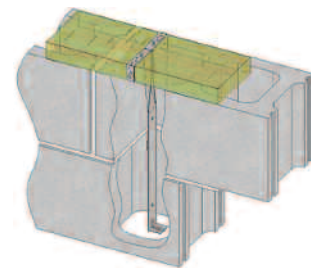
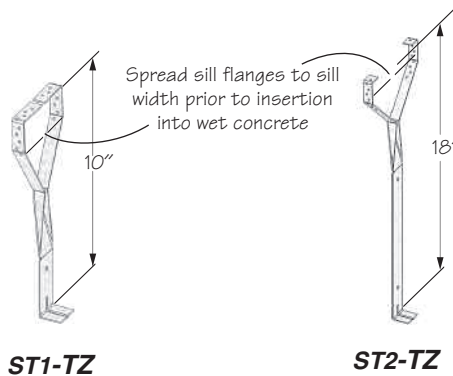

**Alternate
ST2-TZ
installation with
3/4" center hole
in mudsill**

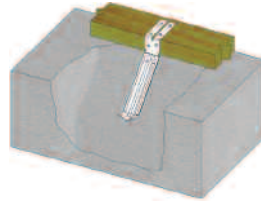
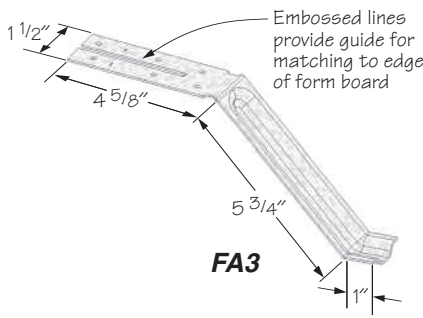

Alternate FA3 installation

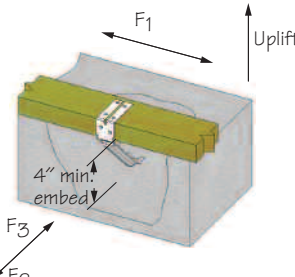

Typical FA3 installation in concrete

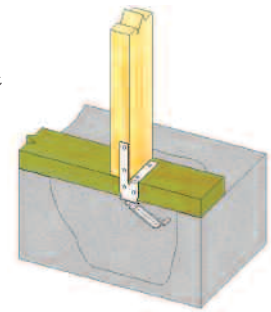

Typical FA3 installation to mudsill and stud

Plate Size	USP Stock No.	Ref. No.	Steel Gauge	Fastener Schedule ²				Min. Embed. ⁴ (E)	Max. Spacing ³ (Feet)	Allowable Loads (Lbs.) ¹				Code Ref.
				Mudsill Top		Mudsill Side				DF-L / SP				
				Qty	Type	Qty	Type			F1	F2	F3	Uplift	
2 x 4 - 6	ST1-TZ	MAB15Z	18	4	8d x 1-1/2	4	8d x 1-1/2	8-1/2"	*5-1/2	565	745	745	825	L6, F16
2 x 4 - 6	ST2-TZ	MAB23Z	18	4	8d x 1-1/2	4	8d x 1-1/2	16-1/2"	*5-1/2	565	745	745	825	
2 x 4 - 6 - 8	FA3	MAS	16	4	10d x 1-1/2	2	10d x 1-1/2	4"	5-1/2	840	705	750	1155	

- 1) Allowable loads have been increased 60% for wind or seismic loads; no further increase shall be permitted.
 - 2) 10d x 1-1/2 nails are 9 gauge (0.148" diameter) by 1-1/2" long.
8d x 1-1/2 nails are 11 gauge (0.131" diameter) by 1-1/2" long.
 - 3) Anchor spacing and design loads assume treated Douglas Fir-Larch with Fc perpendicular @ 625 psi; replaces code prescribed 1/2" anchor bolt with standard washer, spaced 6 ft. on center.
 - 4) If installed in the alternate configuration, the ST1-TZ shall be embedded 11" and ST2-TZ 16".
- *When a 2 x 8 mudsill is used for ST1-TZ or ST2-TZ, maximum spacing is 3 feet unless alternate installation is used.

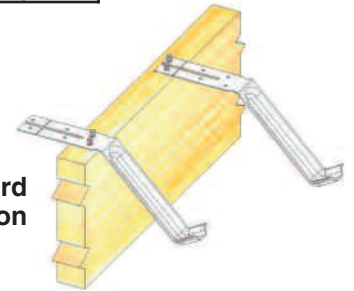

FA3 Form board installation

FOUNDATION ANCHORS – SFA & SFJA SERIES

SFA – Mudsill anchors for retrofit applications. Features a slotted bend line for easy field adjustment when foundation walls are slanted.

SFJA – Ties floor joists directly to foundations with bolt fastening.

Materials: 12 gauge
Finish: G90 galvanizing

Installation:

- Use all specified fasteners. See Product Notes, page 10.
- A design professional must specify anchor bolt type, length, and embedment. Anchor bolts are laterally loaded. See pages 23 & 24 for CIA-EA or CIA-GEL 7000 for epoxy information.
- Allowable loads assume a minimum concrete compressive strength of 2,000 psi.

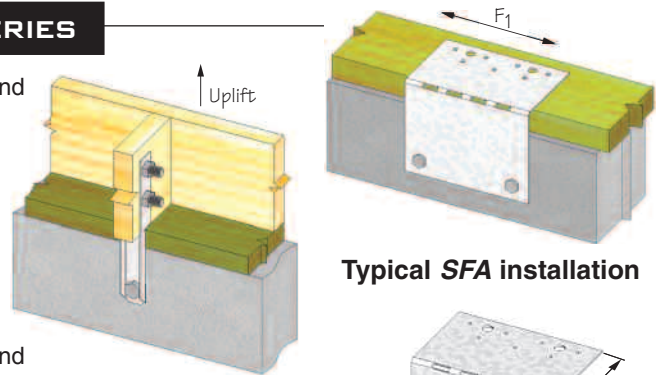

Typical SFA installation

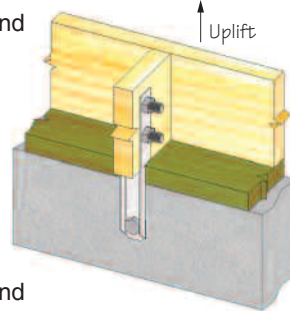

Typical SFJA installation

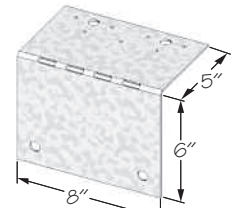

SFA6

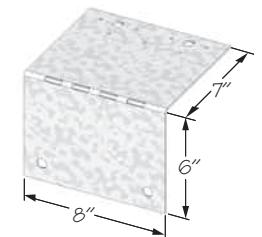

SFA8

USP Stock No.	Ref. No.	Steel Gauge	Fastener Schedule						Allowable Loads (Lbs.) ¹		Code Ref.
			Anchor Bolts		Framing				DF-L / SP		
			Qty	Dia.	Nails ²		Bolts		F1	Uplift	
SFJA	FJA	12	1	5/8	---	---	2	5/8	---	1305	130
SFA6	---	12	2	1/2	7	10d x 1-1/2	---	---	875	---	
SFA8	---	12	2	1/2	7	10d x 1-1/2	---	---	875	---	

- 1) Allowable loads have been increased 60% for wind or seismic loads; no further increase shall be permitted.
- 2) 10d x 1-1/2 nails are 9 gauge (0.148" diameter) by 1-1/2" long.

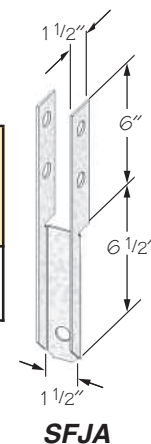

SFJA

KGLB – Single bolt, bearing only.

KGLBT – Double bolt with Structural Tee provides uplift and horizontal resistance.

KHGLB – Double bolt design provides uplift and horizontal resistance.

Materials: Flanges – 1/4" steel
Bearing Plate – See chart
Anchor dowels – 3/4" x 12" rebar

Finish: USP primer

Options: Consult USP for non-catalog variations.

Codes: ER-2725

Installation:

- Use all specified fasteners. See Product Notes, page 10.
- Bolt holes shall be a minimum of 1/32" to a maximum of 1/16" larger than the bolt diameter.
- Concrete or masonry walls must be checked by a design professional for adequacy to resist lateral or uplift loads transferred from the beam seat anchor.

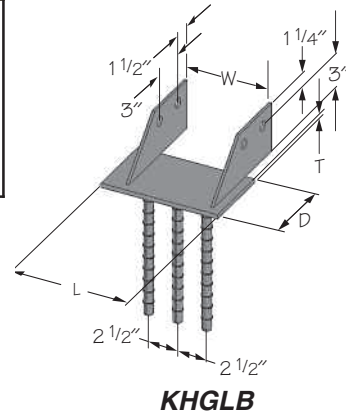
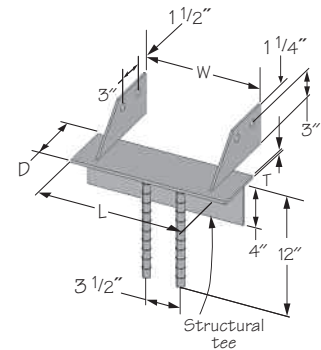
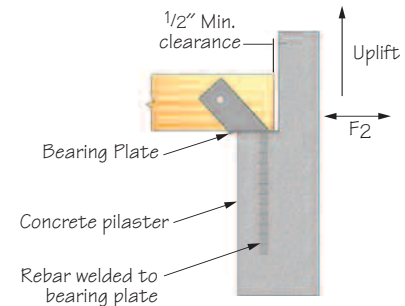
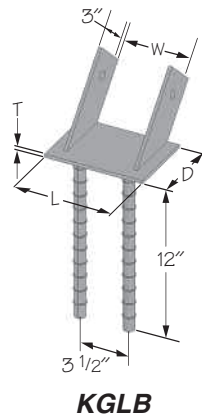

USP Stock No.	Ref. No.	Dimensions				Bolt Schedule		Allowable Bearing Loads (Lbs.) ^{1,4,5}		Code Ref.
		W	L	T	D	Qty	Dia.	Masonry @ 375 psi ²	Concrete ³	
KGLB5A	GLB5A	5-1/4	7	1/4	5	1	5/8	11790	11790	L3, R3
KGLB5B	GLB5B	5-1/4	7	3/8	6	1	5/8	14145	14145	
KGLB5C	GLB5C	5-1/4	7	3/8	7	1	5/8	16505	16505	
KGLB5D	GLB5D	5-1/4	7	3/8	8	1	5/8	18860	18860	
KGLB7A	GLB7A	6-7/8	9	1/4	5	1	3/4	15525	15525	
KGLB7B	GLB7B	6-7/8	9	3/8	6	1	3/4	18630	18630	
KGLB7C	GLB7C	6-7/8	9	3/8	7	1	3/4	21735	21735	
KGLB7D	GLB7D	6-7/8	9	3/8	8	1	3/4	24840	24840	

- 1) Beams must fully bear on plates.
- 2) The loads are based on the bearing value listed times the bearing area equal to W x D. (Note that full bearing plate area is not used.) Bearing loads shall be reduced where limited by wood bearing on the plate.
- 3) The loads on concrete are based on allowable wood bearing stress perpendicular to the grain of 460 psi and actual beam width times beam bearing length.
- 4) Designer shall specify minimum edge and spacing requirements in masonry or concrete structure.
- 5) Concrete or masonry support structure is assumed adequate to support loads listed.

USP Stock No.	Ref. No.	Dimensions				Bolt Schedule		Allowable Bearing Loads (Lbs.) ^{1,5}				F2 ^{3,4}	Uplift 160 ³	Code Ref.	
		Range W	D	L	T	Qty	Dia.	Masonry @ 375 psi	On Concrete with Beam Width ²						
									5-1/8	6-3/4	8-3/4				10-3/4
KHGLBA	HGLBA	3-1/4 to 9	5	10	3/8	2	3/4	18750	11790	15525	20125	---	9870	3905	L3
KHGLBB	HGLBB	3-1/4 to 9	6	10	3/8	2	3/4	22500	14145	18630	24150	---	9870	3905	
KHGLBC	HGLBC	3-1/4 to 9	7	10	3/8	2	3/4	26250	16505	21735	28175	---	9870	3905	
KHGLBD	HGLBD	3-1/4 to 9	8	10	3/8	2	3/4	30000	18860	24840	32200	---	9870	3905	
KGLBT512	GLBT512	3-1/4 to 11	5-1/4	12	5/16	2	3/4	24750	12965	17080	22140	27200	9870	3905	
KGLBT612	GLBT612	3-1/4 to 11	6-1/2	12	3/8	2	3/4	29250	15325	20185	26165	32145	9870	3905	
KGLBT516	GLBT516	3-1/4 to 15	5-1/4	16	5/16	2	3/4	27200	12965	17080	22140	27200	9870	3905	
KGLBT616	GLBT616	3-1/4 to 15	6-1/2	16	3/8	2	3/4	32145	15325	20185	26165	32145	9870	3905	
KGLBT520	GLBT520	3-1/4 to 19	5-1/4	20	5/16	2	3/4	27200	12965	17080	22140	27200	9870	3905	
KGLBT620	GLBT620	3-1/4 to 19	6-1/2	20	3/8	2	3/4	32145	15325	20185	26165	32145	9870	3905	

- 1) Beams must fully bear on plates.
- 2) The loads on concrete are based on allowable wood bearing stress perpendicular to the grain of 460 psi and actual beam width times beam bearing length.
- 3) Allowable loads have been increased 60% for wind or seismic loads and are based on bolt in wood values only. Loads assume concrete or masonry structure is adequate to resist loads in those directions.
- 4) Loads must be reduced if the allowable lateral load (F2) for masonry or concrete column governs.
- 5) Designer shall specify minimum edge and spacing requirements in masonry or concrete structure.

Bolts must be ordered separately. See page 20 for available sizes.

Connects girder beams to foundation walls and eliminates the need to block out pockets or inserts while forming foundation.

- Materials:** 12 gauge
- Finish:** USP primer
- Options:** Consult USP for non-catalog design variations.
- Codes:** ESR-1280, FL11664, LA City RR 25749

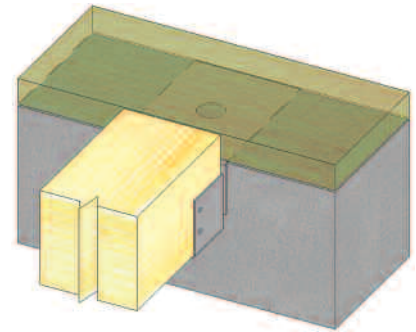

Typical **KGH** installation

Installation:

- Use all specified fasteners. See Product Notes, page 10.
- H dimension assumes 2x mudsill. For 3x or larger mudsill, please contact factory.
- The 1 1/2" hole, centered in the saddle, allows for installation over any protruding foundation bolts. This is not required.
- Placement of a wood sill over the top of the KGH top flange is required to achieve allowable loads.

Girder Size	USP Stock No.	Ref. No.	Steel Gauge	Dimensions					Fastener Schedule ¹		Allowable Loads (Lbs.)		Code Ref.
				W	L	D	S	H	Qty	Type	DF-L / SP		
											100%	125%	
4 x 6	KGH46-6	GH46-6	12	3-9/16	5	3-1/4	6	4	4	16d	2050	2050	2, F20, R12
4 x 6	KGH46-8	GH46-8	12	3-9/16	5	3-1/4	8	4	4	16d	2050	2050	
4 x 8	KGH48-6	GH48-6	12	3-9/16	5	3-1/4	6	6	4	16d	2050	2050	
4 x 8	KGH48-8	GH48-8	12	3-9/16	5	3-1/4	8	6	4	16d	2050	2050	
6 x 6	KGH66-6	GH66-6	12	5-1/2	6-1/4	3-1/4	6	4	4	16d	2035	2035	
6 x 6	KGH66-8	GH66-8	12	5-1/2	6-1/4	3-1/4	8	4	4	16d	2035	2035	
6 x 8	KGH68-6	GH68-6	12	5-1/2	6-1/4	3-1/4	6	6	4	16d	2035	2035	
6 x 8	KGH68-8	GH68-8	12	5-1/2	6-1/4	3-1/4	8	6	4	16d	2035	2035	

1) Minimum header thickness shall be 1-5/8" for 16d nails.
New products or updated product information are designated in red.

Specialty Options Chart – refer to Specialty Options pages 206 to 209 for additional details.

Option	Skewed ^{1,2}	Saddle
Range	1° to 45°	--
Allowable Loads	100% of table load.	100% of table load per side.
Ordering	Add SK, angle required, and right (R) or left (L), to product number. Ex. KGH46-6SK45R	Add SA, and saddle width required to product number. Ex. KGH46-6SA=5-1/2"

1) Skewed hangers with skews greater than 15° may have all joist nailing on outside flange.
2) Skewed hangers with skews greater than 15° require the joist end to be bevel cut.

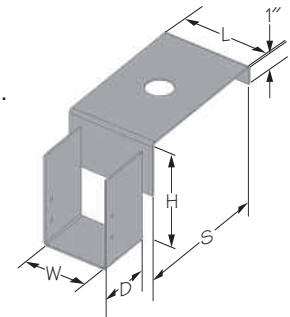

KGH

RETRO PLATE – RP6

Uses heavy gauge HRPO steel and a large surface area to distribute seismic forces on masonry exteriors.

- Materials:** 3/8" plate
- Finish:** USP primer

Installation:

- Install with a 3/4" diameter steel threaded rod.

USP Stock No.	Ref. No.	Code Ref.
RP6	RP6	120

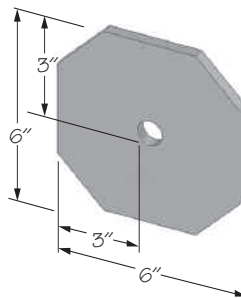

RP6

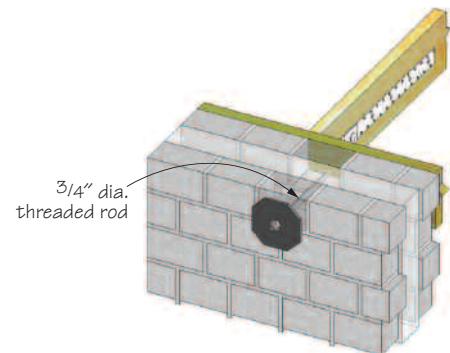

Typical **RP6** installation