

USP Series	Width	Skewed (Maximum)	Sloped Seat (Maximum)	Sloped / Skewed	Sloped Top Flange (Maximum)	Top Flange Offset	Saddle Hanger	Ridge Hanger (Maximum)	Inverted Flange	Uplift	Weldability	USP Series Catalog Page Reference
BPH	all	50°	45°	•	45°					•	•	126, 130-146
GHF	all	50°	45°	•					width ≥ 4-1/2"	•		149
HD ¹	1-3/4" or less > 1-3/4"	67-1/2° 50°	45°	•					width ≥ 2-1/4"	•		92-99, 121, 123-125
HDO	1-3/4" or less > 1-3/4"	67-1/2° 50°	45°	•					width ≥ 3-1/8"	•		101, 103-105
HHDO	all	50°	45°	•					width ≥ 4-1/2"	•		101, 103-105
HJC	all	30°	60°									182
HLBH	all	50°	45°	•	45°	•	•	45°		•	•	127, 130-146
HUS	all								width ≥ 2-1/4"	•		92, 94-99, 122-123
HWUH	all	45°	45°	•		•	•			•		112-112
KB	all									•	•	101, 103-105
KEG	all	45°	45°			•				•		150
KGB	all									•	•	151
KGH	all	45°					•					39
KGLS	all	50°	45°	•	30°	•	•			•	•	155
KGLST	all									•	•	155
KGLT	all	50°	45°	•	45°	•	•			•	•	152
KHB	all									•	•	101, 103-105
KHGB	all									•	•	151
KHGLS	all	50°	45°		30°	•	•			•	•	155
KHGLST	all									•	•	155
KHGLT	all	50°	45°	•	45°	•	•			•	•	152
KHHB	all									•	•	101, 103-105, 151
KHW	all	84°	45°	•	35°	•	•	45°		•	•	102-105
KLB	all									•	•	101, 103
KLEG	all	45°	45°			•				•		150
KMEG	all	45°	45°			•				•		150
LBH	all	50°	45°	•	45°	•	•	45°		•	•	127, 130-146
LSSH	all	45°	45°	•						•		148
MPH ¹	all	60°	45°	•		•						113-114, 128-146
NFM	all	45°								•		115
PH ¹	all	84°	45°	•	35°	•	•	45°		•		128-146
PHI ¹	all	84°	45°	•	35°	•	•	45°		•		128-146
PHM ¹	all	84°	45°	•	35°	•	•	45°		•		128-146
PHX ¹	all	84°	45°	•	35°	•	•	45°		•		128-146
PHXU ¹	all	60°	45°	•	35°	•	•			•	•	128-146
SKH	all	45°								•		107-108
SKHH	all	45°								•		107-108
SUH	1-3/4" or less > 1-3/4"	67-1/2° 50°	45°	•						•		91, 94-99
SW ¹	all	84°	45°	•	35°	•	•	45°		•		102-105
SWH ¹	all	84°	45°	•	35°	•	•	45°		•		102-105
THD	all	45°	45°	•					one flange width ≥ 3"	•		122-125, 172
THDH	all	45°	45°	•						•		122-125, 173
THF	1-3/4" or less > 1-3/4"	67-1/2° 50°	45°	•					width ≥ 2-1/4"	•		121, 123-125

The information listed only applies to hangers manufactured by USP Structural Connectors® and installed according to the instructions listed in this catalog. Some of the options listed may not have been evaluated on a single hanger. The designer must always evaluate each connection, including the joist and header capacities, before specifying a specialty connector. USP sloped hangers are manufactured with the plumb cut of the joist already calculated. If a hanger with a different height is needed, it must be specified at the time of ordering.

Materials: Steel gauge may vary from that specified depending on the specialty option and manufacturing process used. Some formed hangers may be welded when modifying the hanger. Hanger configurations, fastener schedules, and height may vary from the tables depending on the joist size, skew, and slope.

Finish: See specific hanger option tables. Welded hangers are painted with USP gray primer. Non-catalog hangers available in Hot-dip galvanized, use **HDG** after product number.

Allowable Loads: For multiple options for the same connector, use the most conservative reduction to give the lowest design load.

Installation:

- Fill all nail holes with fasteners specified in the tables.
- Fastener quantities may increase from the amount listed in the tables depending on hanger option.
- NA16D-RS, NA20D, and NA25D nails are supplied with hangers.
- For type A skewed hangers, the end of joist must be bevel cut; for type B skewed hangers, the end of joist must be butt-cut.

Codes: Modified hangers are not code evaluated due to their numerous variations.

1) Skews greater than 45° will have square (butt) cut joist with back plate. Refer to Typical PH hanger skewed, left shown, Type B illustration on page 208.

See the Specialty Options Chart for each hanger series for load reductions and hanger maximum range of skew, slope, etc.

Skewed Hanger:

- Consider SKH or SKHH hangers for 45° skews.
- Joist nails may be located on obtuse side to ensure proper nailing.
- Specify skew angle, type (A or B), and direction when ordering.

Sloped Seat Hanger:

- Consider LSSH series for sloped applications.
- Additional nail holes may be added to joist flanges.
- Specify slope angle and direction when ordering.

Sloped/Skewed Hanger:

- See nailing notes for both skewed and sloped hangers.
- Specify skew and slope angles as well as skew/slope directions and skew type (A or B) when ordering.

Inverted Flange Hanger:

- For skewed-only hangers, the flange on the cut side can be inverted at 100% of the table load. Consult USP for skew limitations.
- When nailing into the carrying member's end grain, the allowable load is 0.65 of the table load.
- Hangers with one flange inverted achieve 100% of listed table load.
- Specify right or left flange when inverting only one flange.

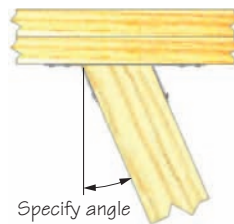

Typical SUH hanger skewed, right shown Type A (bevel cut required)

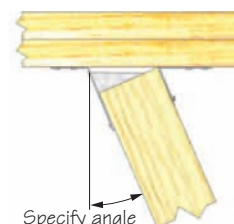

Typical SUH formed hanger skewed, right shown Type B

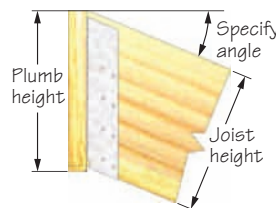

Typical HD hanger sloped seat, down shown

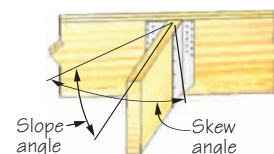

Typical HD hanger sloped down, skewed left shown

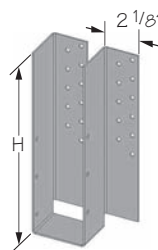

Typical GHF hanger one flange inverted, left shown

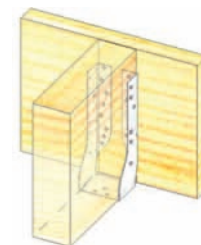

Typical HD hanger inverted flange



See Specialty Options Chart for each hanger series for load reductions and hanger maximum range of skew, slope, etc.

Skewed Hanger:

- Joist nails may be located on obtuse side to ensure proper nailing.
- Specify skew angle, type (A or B), and direction when ordering.

Sloped Seat Hanger:

- Additional nail holes may be added to joist flanges.
- Specify slope angle, direction, and joist height when ordering.

Sloped/Skewed Hanger:

- See nailing notes for both skewed and sloped hangers.
- Specify skew and slope angles as well as skew/slope directions, and skew type (A or B) when ordering.
- Similar to face mount skewed/sloped hanger, refer to illustration on page 207: Typical HD hanger sloped down, skewed left shown.
- Specify if hanger is to be high side flush, low side flush, or center flush.

Sloped/Skewed/Sloped Top Flange Hanger:

- See nailing notes for both skewed and sloped hangers.
- Specify skew, slope, and top flange slope angles as well as skew/slope and top flange slope directions when ordering.
- Skewed/sloped/top flange sloped hangers can be made galvanized or painted.

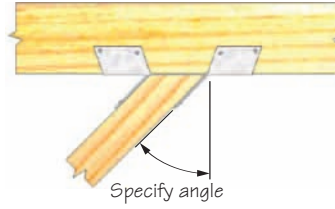

Typical BPH hanger skewed, left shown Type A (bevel cut required)

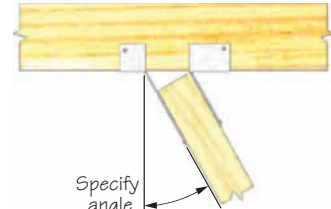

Typical BPH hanger skewed, right shown Type B

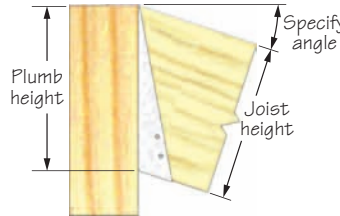

Typical BPH hanger sloped seat, down shown

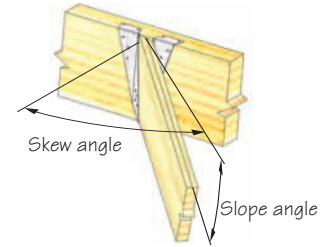

Typical BPH hanger sloped down, skewed right, low side flush shown

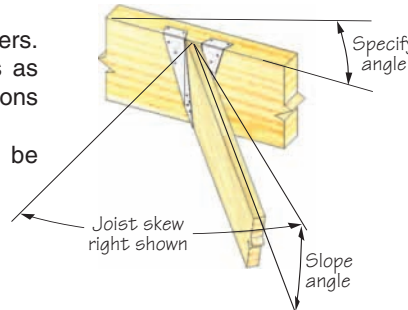

Typical BPH hanger skewed right, sloped down, top flange sloped

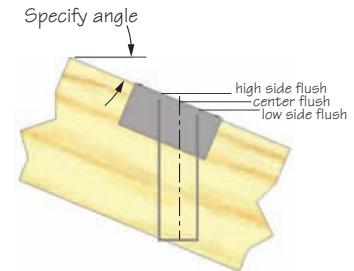

Typical LBH hanger sloped top flange right shown

© Copyright 2007 USP Structural Connectors®

SOLID TOP FLANGE HANGER SPECIALTY DETAILS

See Specialty Options Chart for each hanger series for load reductions and hanger maximum range of skew, slope, etc.

Skewed Hanger:

- Joist nails may be located on obtuse side to ensure proper nailing.
- Specify skew angle, type (A or B), and direction when ordering.

Sloped Seat Hanger:

- Additional nail holes may be added to joist flanges.
- Specify slope angle, direction, and joist height when ordering.

Sloped/Skewed Hanger:

- See nailing notes for both skewed and sloped hangers.
- Specify skew and slope angles as well as skew/slope directions, and skew type (A or B) when ordering.
- Specify if hanger is to be high side flush, low side flush, or center flush.

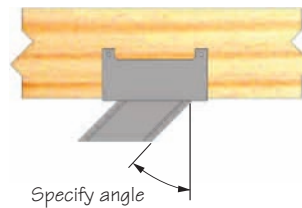

Typical PH hanger skewed, left shown Type A (bevel cut required)

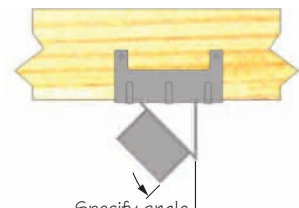

Typical PH hanger skewed, left shown Type B

continued on next page

Sloped Top Flange Hanger:

- Additional nail holes may be added to top angle.
- Specify top flange slope and direction when ordering.
- Specify if hanger is to be high side flush, low side flush, or center flush.

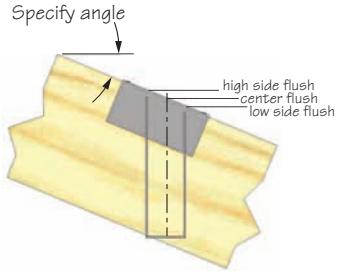
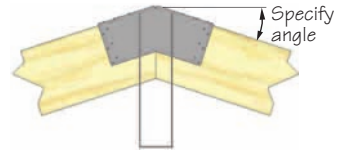
Typical LBH hanger sloped top flange, right shown

Typical LBH hanger ridge, top flange slope
Ridge Hanger:

- Specify flush top of beam at center, right side, or left side.
- Specify angle of slope when ordering.

Top Flange Offset Hanger:

- Specify offset, left (L) or right (R), when ordering.

Saddle Hanger:

- Specify saddle width, "SA" when ordering. Allow clearance for saddled member.

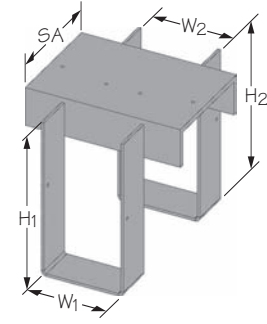
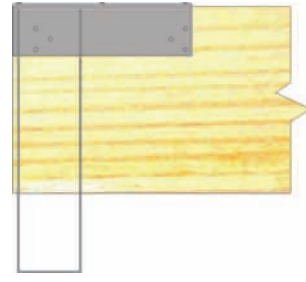
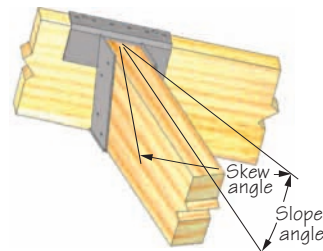
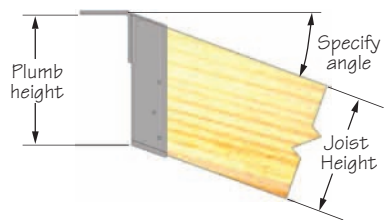
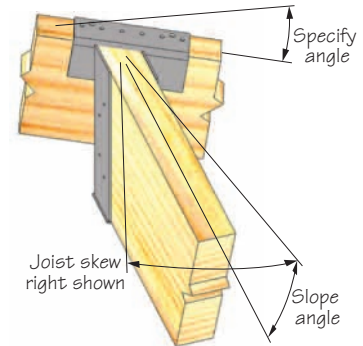
Typical PH hanger saddle option

Typical LBH hanger top flange offset, right shown

Typical LBH hanger sloped down, skewed right, low side flush shown

Typical LBH hanger sloped seat, down shown

Typical LBH hanger skewed right, sloped down, top flange sloped
WELDED TOP FLANGE

- Weld sizes and lengths shown on chart.
- Weld-on applications produce maximum allowable load listed. **Uplift loads do not apply to this application.**

Top Angle Weld Length chart

USP Welded Hanger Series	Weld Length
PH, PHI, SW	3"
BPH, PHM, SWH	4"
KLB, KHW, PHX, PHXU	6"
KB, KHB, LBH, KGB, KHGB, KHHB, KGLS, KGLST, KGLT, KHGLS, KHGLST	8"
HLBH, KHGLT	10"

Top Angle Steel Gauge	Weld Size
10 gauge or lighter	1/8"
7 gauge	3/16"
3 gauge	1/4"

Weld shall be distributed evenly.

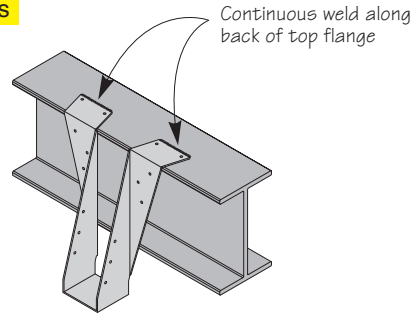
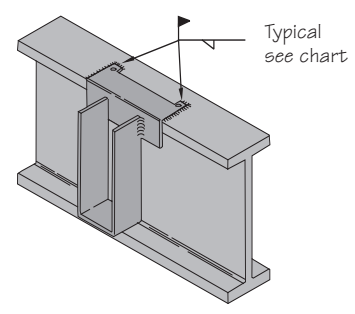
Typical Top Flange welded installation

Typical Top Angle welded installation