

BOARD OF
BUILDING AND SAFETY
COMMISSIONERS

MARSHA L. BROWN
PRESIDENT

VAN AMBATIELOS
VICE-PRESIDENT

VICTOR H. CUEVAS
HELENA JUBANY
ELENORE A. WILLIAMS

CITY OF LOS ANGELES

CALIFORNIA



ANTONIO R. VILLARAIGOSA
MAYOR

DEPARTMENT OF
BUILDING AND SAFETY
201 NORTH FIGUEROA STREET
LOS ANGELES, CA 90012

ROBERT R. "BUD" OVROM
GENERAL MANAGER

RAYMOND S. CHAN, P.E., S.E.
EXECUTIVE OFFICER

United Steel Products Company
14305 Southcross Drive, Suite 200
Burnsville, MN 55306

Attn: Don Stehler, P.E.
(952) 898-8772

RESEARCH REPORT: RR 25779
(CSI # 06 05 23)

BASED UPON ICC EVALUATION SERVICE
REPORT NO. ESR-1881

REEVALUATION DUE

DATE: August 1, 2012
Issued Date: August 1, 2011
Code: 2011 LABC

GENERAL APPROVAL – Reevaluation/Clerical Modification - USP Structural Connectors – CLPBF Butterfly Hanger, CMST Coil Strap, HCPRS Hurricane/ Seismic Anchor, HUS Slant Nail Joist Hanger, JUS Slant Joist Hanger, MP_F Multi-Lateral Plate Tie, PAU Post Anchor, RSPT Stud Plate Tie, SPT and SPTH Stud Plate Ties, and THDH Face Mount Hanger.

DETAILS

The above assemblies and/or products are approved when in compliance with the description, use, identification and findings of Report No. ESR-1881, reissued May 1, 2011, of the ICC Evaluation Service, Incorporated. The report, in its entirety, is attached and made part of this general approval.

The parts of Report No. ESR-1881 marked by the asterisks are deleted or revised by the Los Angeles Building Department from this approval.

The approval is subject to the following conditions:

1. The required spacing and size of the framing connectors shall be determined by a licensed civil or structural engineer or architect registered in the State of California. The spacing, size and location of the anchors shall be detailed on the approved set of plans.
2. Allowable loads in tables are for the wood fastening devices and its fasteners and do not include supporting members. The supporting members shall be checked separately for structural adequacy.

RR 25779
Page 1 of 3

United Steel Products Company

RE: USP Structural Connectors

3. The values shown in this report shall not be used in the repair, retrofit and new construction of tilt-up and masonry wall anchorage (in tension) for the connection with the horizontal wood diaphragm.
4. Steel materials shall conform to the specification as shown on the referenced Evaluation Report. Test data verifying the properties of the steel, by the mill or by an approved testing agency, shall be obtained for each shipment. The data shall be kept on file and submitted to the Department upon request.
5. All welded products shall be fabricated by Los Angeles City Department of Building and Safety licensed fabricator.
6. Nails shall be common nails except where otherwise specified. Bolts shall conform to ASTM A307 or better. Fasteners in preservative-treated and fire –retardant-treated wood shall comply with Section 2304.9.5 of the 2011 City of Los Angeles Building Code.
7. Solid blocking shall be required for all joist hangers supporting roof joists having one end twisted more than one-half degree per foot of length relative to the other end.
8. Approved products to be used shall be indicated on the approved set of plans.
9. Mill test report on steel physical and chemical properties shall be kept on file and submit to this office for review upon request.
10. Product modification shall not be permitted without approval from this office and United Steel Products Company. Field welding shall not be performed without prior approval from this office, structural plan check engineer, and United Steel Products Company.
11. Approved products shall be identified with the name “United Steel Products Company” or the “USP” trademark along with the model number labeled on them.

DISCUSSION

The clerical modification is to change the contact person.

This report is in compliance with the 2011 City of Los Angeles Building Code.

The approval is based on tests in accordance with ICC ES Acceptance Criteria for Joist Hangers and Similar Devices (AC 13).

This general approval will remain effective provided the Evaluation Report is maintained valid and unrevised with the issuing organization. Any revision to the report must be submitted to this Department for review with appropriate fee to continue the approval of the revised report.

United Steel Products Company
RE: USP Structural Connectors

Addressee to whom this Research Report is issued is responsible for providing copies of it, complete with any attachments indicated, to architects, engineers and builders using items approved herein in design or construction which must be approved by Department of Building and Safety Engineers and Inspectors.

This general approval of an equivalent alternate to the Code is only valid where an engineer and/or inspector of this Department has determined that all conditions of this Approval have been met in the project in which it is to be used.

WILLIAM STUTSMAN, Chief
Engineering Research Section
201 N. Figueroa St., Room 880
Los Angeles, CA 90012
Phone - 213-202-9812
Fax - 213-202-9943

BG:bg
RR25779/MSWord2007
R07/20/2011
SD2/2303.5

Attachment: ICC ES Report No. ESR-1881 (14 Pages)

ICC-ES Evaluation Report

ESR-1881

Reissued May 1, 2011

This report is up for renewal January 1, 2013.

www.icc-es.org | (800) 423-6587 | (562) 699-0543

A Subsidiary of the International Code Council®

**DIVISION: 06 00 00—WOOD, PLASTICS AND
COMPOSITES**
**Section: 06 05 23—Wood, Plastic, and Composite
Fastenings**
REPORT HOLDER:

UNITED STEEL PRODUCTS COMPANY
 14305 SOUTHCROSS DRIVE, SUITE 200
 BURNSVILLE, MINNESOTA 55306
 (952) 898-8772
www.uspconnectors.com
info@uspconnectors.com

EVALUATION SUBJECT:
USP STRUCTURAL CONNECTORS
1.0 EVALUATION SCOPE
Compliance with the following codes:

- 2009 and 2006 *International Building Code*® (IBC)
- * ■ ~~2009 and 2006 *International Residential Code*® (IRC)~~

Property evaluated:

Structural

2.0 USES

The USP structural connectors described in this report (see Table 1 for a complete listing) are used for connecting wood framing members in accordance with Section 2304.9.3 of the IBC. They may also be used in structures regulated under the IRC when an engineered design is submitted in accordance with IRC Section R301.1.3.

3.0 DESCRIPTION
3.1 CLPBF Butterfly Hanger:

The CLPBF Butterfly Hanger is a face-mount hanger with triangular header flanges having prepunched nail holes for joist-to-header or truss-to-truss connections. The CLPBF Butterfly Hanger is cold-formed from No. 18 gage steel and is prepunched for 10d common nails into the header and 10d-by-1¹/₂-inch nails into the joist. See Figure 1 and Table 2 for product dimensions, fastener schedule, allowable loads, and a typical installation detail.

3.2 CMST Coil Strap:

The CMST Coil Strap is designed for resisting tension loads for a variety of wood framing applications. The CMST Coil Strap is cold-formed from either No. 12 or No. 14 gage steel in lengths of 40 and 52¹/₂ feet (12.2 and 16.0 m), respectively. The CMST Coil Strap is prepunched

for either 10d common or 16d common nails. See Figure 2 and Table 3 for product dimensions, fastener schedule, allowable loads, and a typical installation detail.

3.3 HCPRS Hurricane/Seismic Anchor:

The HCPRS Hurricane/Seismic Anchor is designed to tie trusses and rafters or nominally dimensioned 2-by wall studs to bottom plates for the purpose of resisting uplift, lateral and transverse loads. The HCPRS Hurricane/Seismic Anchor is cold-formed from No. 18 gage steel and is prepunched for 8d common or 8d-by-1¹/₂-inch nails. See Figure 3 and Table 4 for product dimensions, fastener schedule, allowable loads, and a typical installation detail.

3.4 HUS Slant Nail Joist Hanger:

The HUS Slant Nail Joist Hanger is designed to provide double shear nailing for joist/truss-to-beam connections. The HUS Slant Nail Joist Hanger is cold-formed from No. 14 gage or No. 16 gage steel and is prepunched for 16d common nails into both the joist and the header. See Figure 4 and Table 5 for product dimensions, fastener schedule, allowable loads, and typical installation details.

3.5 JUS Slant Nail Joist Hanger:

The JUS Slant Nail Joist Hanger is designed for face-mount applications to provide double shear nailing for joist/truss-to-beam connections. The JUS Slant Nail Joist Hanger is cold-formed from No. 18 gage steel and is prepunched for either 10d common or 16d common nails into both the joist and the header. See Figure 5 and Table 6 for product dimensions, fastener schedule, allowable loads, and a typical installation detail.

3.6 MP_F Multi-Lateral Plate Tie:

The MP_F Multi-Lateral Plate Tie is designed to transfer lateral loads in top plate-to-rim joist applications or for blocking applications. The MP_F Multi-Lateral Plate Tie is cold-formed from No. 20 gage steel and is prepunched for either 8d common or 8d-by-1¹/₂-inch nails. See Figure 6 and Table 7 for product dimensions, fastener schedule, allowable loads, and a typical installation detail.

3.7 PAU Post Anchor:

The PAU Post Anchor is designed to secure wood posts to concrete or masonry members. The PAU Post Anchor is comprised of three components: an anchor base, a stand-off plate, and a washer. The anchor base is cold-formed from No. 10 gage or No. 12 gage steel. The stand-off plate is cold-formed from either No. 12 gage or No. 16 gage steel. The washer is cut from No. 3 gage or No. 10 gage steel. The PAU Post Anchor is fastened to the post with either 16d common nails or 1¹/₂-inch-diameter (12.7 mm)

bolts. The PAU Post Anchor is fastened to the concrete or masonry foundation utilizing ⁵/₈-inch-diameter (15.9 mm) anchor bolts, expansion anchors or threaded rod, which must be designed separately. See Figure 7 and Table 8 for product dimensions, required fastener schedule, allowable loads, and a typical installation detail.

3.8 RSPT Stud Plate Tie:

The RSPT Stud Plate Tie is designed to connect wall studs to single- or double-top plates or sill plates. The RSPT Stud Plate Tie is cold-formed from No. 18 gage or No. 20 gage steel, and prepunched for either 10d common, 10d-by-1¹/₂-inch, 8d common, or 8d-by-1¹/₂-inch nails. See Figure 8 and Table 9 for product dimensions, fastener schedule, allowable loads, and typical installation details.

3.9 SPT and SPTH Stud Plate Ties:

SPT and SPTH Stud Plate Ties are designed to connect wall studs to single- or double-top plates. SPT and SPTH Stud Plate Ties are cold-formed from No. 20 gage and No. 18 gage steel, respectively, and are prepunched for 10d-by-1¹/₂-inch nails. See Figure 9 and Table 10 for product dimensions, fastener schedule, allowable loads, and a typical installation detail.

3.10 THDH Face Mount Hanger:

The THDH Face Mount Hanger is designed as a hanger for metal-plate-connected wood trusses. The THDH Face Mount Hanger is cold-formed from No. 12 gage steel and is prepunched for 16d common nails. See Figure 10 and Table 11 for product dimensions, fastener schedule, allowable loads, and a typical installation detail.

3.11 Materials:

3.11.1 Steel: The specific types of steel and corrosion protection for each product are described in Table 12 of this report. Minimum steel base-metal thicknesses for the different gages are shown in the following table:

GAGE NO.	MINIMUM BASE-METAL THICKNESS (inch)
20	0.033
18	0.044
16	0.055
14	0.070
12	0.099
10	0.129
3	0.240

For SI: 1 inch = 25.4 mm.

3.11.2 Wood: Wood members must be sawn lumber or structural glued laminated timber with a minimum specific gravity of 0.50, or approved structural engineered lumber (structural composite lumber, alternative strand lumber, or prefabricated wood I-joists) with a minimum equivalent specific gravity of 0.50, unless otherwise noted in the applicable table within this report. Wood members must have a moisture content not exceeding 19 percent (16 percent for structural engineered lumber), except as noted in Section 4.1. For connectors installed with nails, the thickness of each wood member must be sufficient such that the specified fasteners do not protrude through the opposite side of the member, unless otherwise permitted in the applicable table within this report. Wood members that are structural engineered lumber must be recognized in, and used in accordance with, a current evaluation report. Refer to Section 3.11.4 for issues related to treated wood.

3.11.3 Fasteners: Required fastener types and sizes for use with the USP structural connectors described in this report are specified in this section and Tables 2 through 12.

3.11.3.1 Bolts: At a minimum, bolts must comply with ASTM A 36 or ASTM A 307, and must have a minimum bending yield strength of 45,000 lbf/in² (310 MPa). Bolt diameters must be as specified in the applicable tables of this report.

3.11.3.2 Nails: Nails used for connectors described in this report must comply with material requirements, physical properties, tolerances, workmanship, protective coating and finishes, and packaging and package marking requirements specified in ASTM F 1667; and must have lengths, diameters and bending yield strengths as shown in Table 12 of this report

FASTENER DESIGNATION	FASTENER LENGTH (inches)	SHANK DIAMETER (inch)	MINIMUM REQUIRED F _{yb} (lbf/in ²)
8d x 1 ¹ / ₂	1.5	0.131	100,000
8d common	2.5	0.131	100,000
10d x 1 ¹ / ₂	1.5	0.148	90,000
10d common	3.0	0.148	90,000
16d common	3.5	0.162	90,000
¹ / ₂ " dia. bolt	Varies	0.500	45,000
⁵ / ₈ " dia. bolt	Varies	0.625	45,000

For SI: 1 inch = 25.4 mm, 1 psi = 6.89 kPa.

3.11.4 Use in Treated Wood: Connectors and fasteners used in contact with preservative-treated or fire-retardant-treated wood must comply with IBC Section 2304.9.5 or IRC Section R319.3. The lumber treater or the report holder (United Steel Products Company), or both, should be contacted for recommendations on the appropriate level of corrosion resistance to specify for the connectors and fasteners as well as the connection capacities of the fasteners used with the specific proprietary preservative-treated or fire-retardant-treated lumber.

3.11.5 Concrete and Masonry Construction: Materials and quality of concrete and masonry construction must comply with the applicable provisions of Chapters 19 and 21 of the IBC. The compressive strength of the concrete and masonry construction must be in accordance with the approved design and with applicable provisions of the building code.

4.0 DESIGN AND INSTALLATION

4.1 Design:

The allowable load capacities in Tables 2 through 12 are based on allowable stress design. The use of the allowable load values for the products listed in Table 1 of this report must comply with all applicable requirements and conditions specified in this report. Tabulated allowable loads are for normal duration and/or short duration, based on load duration factors, C_D, in accordance with Section 10.3.2 of the NDS, as indicated in Tables 2 through 12 of this report. No further increases are permitted for load durations other than those specified. Tabulated allowable loads are for connections in wood seasoned to a maximum moisture content of 19 percent (16 percent for engineered wood products) or less, used under continuously dry conditions and where sustained temperatures are limited to 100°F (37.8°C) or less. When connectors are installed in wood having a moisture content greater than 19 percent (16 percent for engineered wood products), or where the

in-service moisture content is expected to exceed this value, the applicable wet service factor, C_M , must be applied. Unless otherwise noted in the tables of this report, the applicable wet service factor, C_M , is as specified in the NDS for lateral loading of dowel-type fasteners. When connectors are installed in wood that will experience sustained exposure to temperatures exceeding 100°F (37.8°C), the allowable loads in this evaluation report must be adjusted by the temperature factor, C_t , specified in Section 10.3.4 of the NDS. The group action factor, C_g , has been accounted for, in accordance with Section 10.3.6 of the NDS, in the tabulated allowable loads, where applicable. For connectors installed with bolts, minimum edge distances and end distances within the wood members must be met, such that the geometry factor, C_{Δ} , is 1.0, in accordance with NDS Section 11.5.1. Connected wood members must be checked for load-carrying capacity at the connection in accordance with NDS Section 10.1.2.

For connectors with anchors intended to transmit loads into concrete or masonry, adequate embedment length and anchorage details, including edge and end distances, must be determined by a registered design professional in accordance with Chapter 19 or 21 of the IBC, as applicable, for design of anchorage to concrete and masonry structural members.

Where design load combinations include earthquake loads or effects, the design strength of anchorage to concrete for the PAU Post Anchor (Table 8) must be determined in accordance with Section 1912 of the IBC, except for detached one- and two-family dwellings assigned to Seismic Design Category A, B or C, or located where the mapped short-period spectral response acceleration, S_s , is less than 0.4g.

4.2 Installation:

Installation of the connectors must be in accordance with this evaluation report and the manufacturer's published installation instructions. Bolts must be installed in accordance with NDS Section 11.1.2.

4.3 Special Inspection:

4.3.1 IBC: Periodic special inspection is required for installation of connectors described in this report that are designated as components of the seismic-force-resisting system for structures in Seismic Design Category C, D, E or F in accordance with IBC Section 1707.3 or 1707.4, with the exception of those structures that qualify under the Exceptions to Section 1704.1.

4.3.2 IRC: Special inspections are not required for connectors used in structures regulated under the IRC.

5.0 CONDITIONS OF USE

The USP Structural Connectors described in this report comply with, or are suitable alternatives to what is specified in, those codes listed in Section 1.0 of this report, subject to the following conditions:

- 5.1 The connectors must be manufactured, identified and installed in accordance with this report and the manufacturer's published installation instructions. A copy of the manufacturer's published installation instructions must be available at the jobsite at all times during installation. In the event of a conflict between this report and the manufacturer's published installation instructions, this report governs.
- 5.2 Calculations showing compliance with this report must be submitted to the code official. The calculations must be prepared by a registered design professional where required by the statutes of the jurisdiction in which the project is to be constructed.
- 5.3 Connected wood members and fasteners must comply with Sections 3.11.2 and 3.11.3, respectively.
- 5.4 Adjustment factors, noted in Section 4.1 of this report and the applicable codes, must be considered where applicable.
- 5.5 Use of connectors and fasteners with preservative-treated or fire-retardant-treated lumber must be in accordance with Section 3.11.4.
- 5.6 The design of the anchorage to, and bearing upon, concrete or masonry construction, inclusive of cast-in-place and post-installed anchors, used to attach the connectors described in this report to concrete or masonry construction, is outside of the scope of this report.

6.0 EVIDENCE SUBMITTED

Data in accordance with the ICC-ES Acceptance Criteria for Joist Hangers and Similar Devices (AC13), dated October 2010.

7.0 IDENTIFICATION

Each connector described in this report is identified by the product model (stock) number, the number of the ICC-ES index evaluation report for United Steel Products Company ([ESR-2685](#)), and by one or more of the following designations: USP, or United Steel Products Company.

TABLE 1—CROSS-REFERENCE OF PRODUCT NAMES WITH APPLICABLE REPORT SECTIONS, TABLES AND FIGURES

PRODUCT NAME	SECTION	TABLE NO.	FIGURE NO.
CLPBF Butterfly Hanger	3.1	2	1
CMST Coil Strap	3.2	3	2
HCPRS Hurricane/Seismic Anchor	3.3	4	3
HUS Slant Nail Joist Hanger	3.4	5	4
JUS Slant Nail Joist Hanger	3.5	6	5
MP_F Multi-Lateral Plate Tie	3.6	7	6
PAU Post Anchor	3.7	8	7
RSPT Stud Plate Tie	3.8	9	8
SPT and SPTH Stud Plate Ties	3.9	10	9
THDH Face Mount Hanger	3.10	11	10

TABLE 2—CLPBF BUTTERFLY HANGER ALLOWABLE LOADS^{1,2,3,4}

STOCK NO.	JOIST WIDTH (in.)	STEEL GA.	DIMENSIONS			FASTENER SCHEDULE				ALLOWABL LOADS (lbs)			
			W	H	D	Header		Joist		Download			Uplift
						Qty	Type	Qty	Type	c _D =1.0	c _D =1.15	c _D =1.25	c _D =1.60
CLPBF	1 1/2	18	1 ⁹ / ₁₆	2 1/2	2 1/2	12	10d Common	6	10dx 1 1/2	815	815	815	215

For SI: 1 inch = 25.4 mm, 1 lb. = 4.45 N.

¹Allowable loads have been adjusted for load duration factors, C_D, as shown, in accordance with the NDS. The allowable loads do not apply to loads of other durations, and are not permitted to be adjusted for other load durations. See Sections 4.1 and 4.2 for additional design and installation requirements.

²See Section 3.11.3 for required fastener dimensions and mechanical properties.

³Allowable loads shown are for installations in wood members complying with Section 3.11.2. Wood members must also have a reference compression perpendicular to grain design value, F_{c⊥}, of 625 psi (4.31 MPa) or greater.

⁴CLPBF hangers provide torsional resistance up to a maximum joist depth of 3.5 inches (88.9 mm), where torsional resistance is defined as a moment not less than 75 pounds (334 N) times the depth of the joist at which the lateral movement of the top or bottom of the joist with respect to the vertical position of the joist is 0.125 inch (3.2 mm).

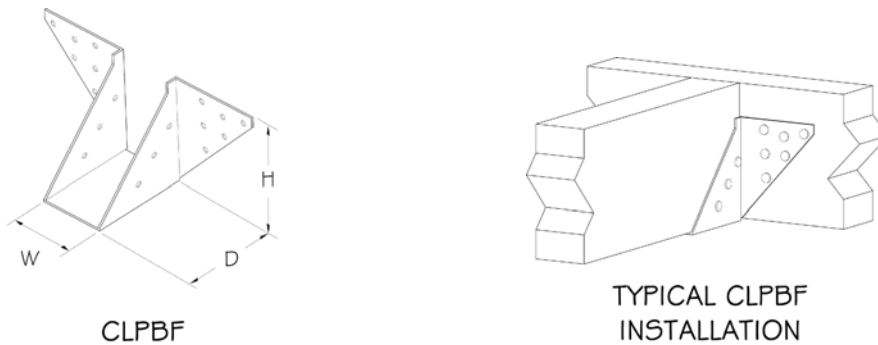

FIGURE 1—CLPBF BUTTERFLY HANGER

TABLE 3—CMST COIL STRAP ALLOWABLE LOADS^{1,2,3,4}

STOCK NO.	STEEL GAGE	DIMENSIONS		RIM JOIST INSTALLATION		FASTENER SCHEDULE			ALLOWABLE TENSION (lbs) C _D = 1.6
		Width (in.)	Coil Length (feet)	Cut Length	End Length	Min. Qty.	Type	Nail Spacing (O.C.)	
Installed in wood with a specific gravity of 0.50 or greater									
CMST12	12	3	40	Clear Span + 74"	37"	82	16d Common	1 ³ / ₄ "	9320
				Clear Span + 168"	84"	96	10d Common	3 ¹ / ₂ "	
				Clear Span + 332"	166"		7"		
CMST14	14	3	52 ¹ / ₂	Clear Span + 58"	29"	64	16d Common	1 ³ / ₄ "	6630
				Clear Span + 130"	65"	74	10d Common	3 ¹ / ₂ "	
				Clear Span + 256"	128"		7"		
Installed in wood with a specific gravity from 0.42 to 0.49									
CMST12	12	3	40	Clear Span + 90"	45"	102	16d Common	1 ³ / ₄ "	9320
				Clear Span + 206"	103"	118	10d Common	3 ¹ / ₂ "	
				Clear Span + 410"	205"		7"		
CMST14	14	3	52 ¹ / ₂	Clear Span + 72"	36"	80	16d Common	1 ³ / ₄ "	6630
				Clear Span + 164"	82"	94	10d Common	3 ¹ / ₂ "	
				Clear Span + 326"	163"		7"		

For SI: 1 inch = 25.4 mm, 1 lbf = 4.45 N.

¹Allowable loads have been adjusted for a load duration factor, C_D, of 1.6, corresponding to a ten-minute load duration (i.e., wind or earthquake loading), in accordance with the NDS. The allowable loads do not apply to loads of other durations. See Sections 4.1 and 4.2 for additional design and installation requirements.

²See Section 3.11.3 for required fastener dimensions and mechanical properties.

³Allowable loads shown are for installations in wood members complying with Section 3.11.2 except that the CMST coil strap may be attached to wood members having a specific gravity from 0.42 to 0.49, as shown.

⁴The minimum fastener quantity indicated is the minimum number fasteners required at each end of the connection. Products may have additional holes not needed to meet the allowable tension load of the strap.

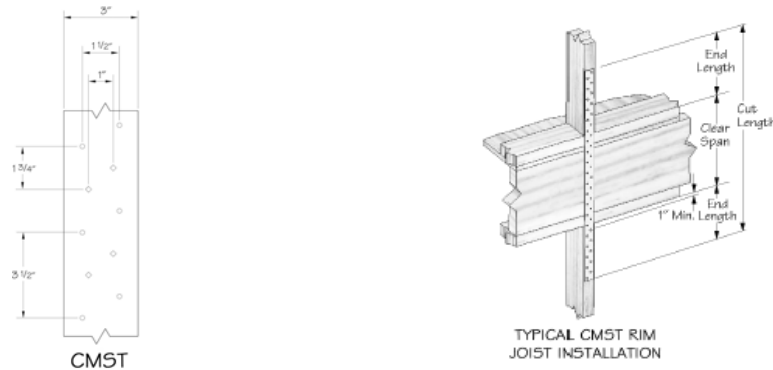

FIGURE 2—CMST COIL STRAP

TABLE 4—HCPRS HURRICANE / SEISMIC ANCHOR ALLOWABLE LOADS^{1,2,3,4,5,6}

STOCK NO.	STEEL GAGE	FASTENER SCHEDULE				LOAD DIRECTION	ALLOWABLE LOADS (lbs) C _D = 1.6
		Plate		Stud			
		Qty.	Type	Qty	Type		
HCPRS	18	5	8d Common	6	8d Common	Uplift	540
						F1	500
						F2	340
		5	8dx1½	6	8dx1½	Uplift	540
						F1	500
						F2	205

For SI: 1 inch = 25.4 mm, 1 lbf = 4.45 N.

¹Allowable loads have been adjusted for a load duration factor, CD, of 1.6, corresponding to a ten-minute load duration (i.e., wind or earthquake loading), in accordance with the NDS. The allowable loads do not apply to loads of other durations. See Sections 4.1 and 4.2 for additional design and installation requirements.

²See Section 3.11.3 for required fastener dimensions and mechanical properties.

³Allowable loads shown are for installations in wood members complying with Section 3.11.2.

⁴The F1 load direction is for lateral loading within the plane of the wall. The F2 load direction is for lateral loading perpendicular to the plane of the wall.

⁵Tabulated allowable loads are for a single connector. HCPRS connectors should be installed in pairs at opposite sides of the stud to reduce eccentricity.

⁶Nails into pressure-treated bottom / sill plates must have a level of corrosion resistance that is compatible with the preservative treatment. See Section 3.11.4 of this report.

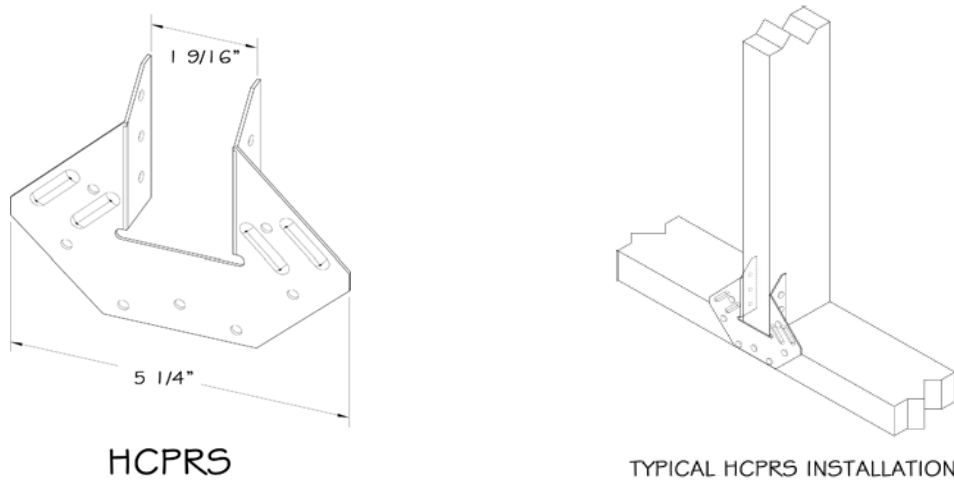

FIGURE 3—CMST COIL STRAP

TABLE 5—HUS SLANT NAIL JOIST HANGER ALLOWABLE LOADS^{1,2,3,4}

STOCK NO.	STEEL GAGE	DIMENSIONS (in.)				FASTENER SCHEDULE				ALLOWABLE DESIGN LOADS (lbs.)			
		W	H	D	A	Header		Joist		Download			Uplift
						Qty	Type	Qty	Type	C _D = 1.0	C _D = 1.15	C _D = 1.25	C _D = 1.6
HUS26	16	1 ⁵ / ₈	5 ⁷ / ₁₆	3	2	14	16d Common	6	16d Common	2635	3030	3295	1925
HUS28	16	1 ⁵ / ₈	7 ³ / ₁₆	3	2	22	16d Common	8	16d Common	3970	4345	4345	2570
HUS210	16	1 ⁵ / ₈	9 ³ / ₁₆	3	2	30	16d Common	10	16d Common	5310	5510	5510	3205
HUS175	16	1 ¹³ / ₁₆	5 ³ / ₈	3	2	14	16d Common	6	16d Common	2635	3030	3295	1925
HUS177	16	1 ¹³ / ₁₆	7 ¹ / ₈	3	2	22	16d Common	8	16d Common	3975	4345	4345	2570
HUS179	16	1 ¹³ / ₁₆	9 ¹ / ₈	3	2	30	16d Common	10	16d Common	5310	5510	5510	3205
HUS24-2	14	3 ¹ / ₈	3 ⁷ / ₁₆	2	1	4	16d Common	2	16d Common	800	920	1000	495
HUS26-2	14	3 ¹ / ₈	5 ¹ / ₄	2	1	4	16d Common	4	16d Common	1030	1185	1290	1115
HUS28-2	14	3 ¹ / ₈	7 ¹ / ₈	2	1	6	16d Common	6	16d Common	1550	1780	1935	1810
HUS210-2	14	3 ¹ / ₈	9 ¹ / ₈	2	1	8	16d Common	8	16d Common	2065	2375	2580	2210
HUS212-2	14	3 ¹ / ₈	11 ¹ / ₈	2	1	10	16d Common	10	16d Common	2580	2965	3225	3060
HUS214-2	14	3 ¹ / ₈	13 ¹ / ₈	2	1	12	16d Common	12	16d Common	3095	3560	3870	3060
HUS46	14	3 ⁵ / ₈	5	2	1	4	16d Common	4	16d Common	1030	1185	1290	1115
HUS48	14	3 ⁵ / ₈	7	2	1	6	16d Common	6	16d Common	1550	1780	1935	1810
HUS410	14	3 ⁵ / ₈	8 ⁷ / ₈	2	1	8	16d Common	8	16d Common	2065	2375	2580	2210
HUS412	14	3 ⁵ / ₈	10 ⁷ / ₈	2	1	10	16d Common	10	16d Common	2580	2965	3225	3060

For SI: 1 inch = 25.4 mm, 1 lbf = 4.45 N.

¹Allowable loads have been adjusted for load duration factors, CD, as shown, in accordance with the NDS. The allowable loads do not apply to loads of other durations, and are not permitted to be adjusted for other load durations. See Sections 4.1 and 4.2 for additional design and installation requirements.

²Allowable loads shown are for installations in wood members complying with Section 3.11.3. Wood members must also have a reference compression perpendicular to grain design value, F_{c⊥}, of 625 psi (4.31 MPa) or greater.

³See Section 3.11.3 for required fastener dimensions and mechanical properties.

⁴HUS hangers provide torsional resistance, where torsional resistance is defined as a moment not less than 75 pounds (334 N) times the depth of the joist at which the lateral movement of the top or bottom of the joist with respect to the vertical position of the joist is 0.125 inch (3.2 mm).

⁵Joist nails must be driven horizontally into the joist at an angle of 30- to 45-degrees from normal, such that they penetrate through the joist, and into the header.

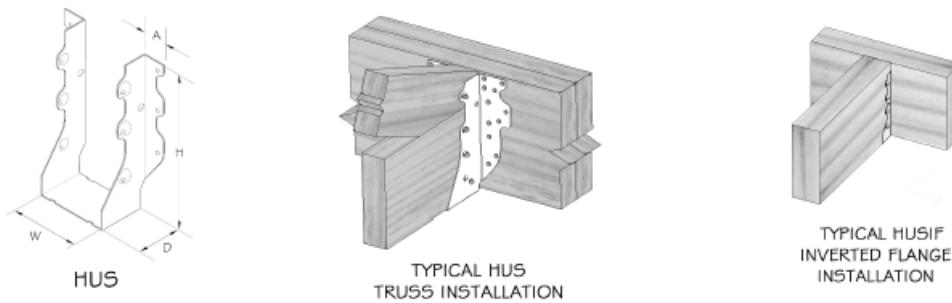

FIGURE 4—HUS SLANT NAIL JOIST HANGER

TABLE 6—JUS SLANT NAIL JOIST HANGER ALLOWABLE LOADS^{1,2,3,4}

STOCK NO.	STEEL GAGE	DIMENSIONS (in.)				FASTENER SCHEDULE				ALLOWABLE DESIGN LOADS (lbs.)			
		W	H	D	A	Header		Joist		Download			Uplift
						Qty	Type	Qty	Type	C _D = 1.0	C _D = 1.15	C _D = 1.25	C _D = 1.6
JUS24	18	1 ⁹ / ₁₆	3 ¹ / ₈	1 ³ / ₄	1	4	10d Common	2	10d Common	655	750	820	510
JUS26	18	1 ⁹ / ₁₆	4 ¹³ / ₁₆	1 ³ / ₄	1	4	10d Common	4	10d Common	850	975	1060	1115
JUS28	18	1 ⁹ / ₁₆	6 ⁵ / ₈	1 ³ / ₄	1	6	10d Common	4	10d Common	1075	1235	1345	1115
JUS210	18	1 ⁹ / ₁₆	7 ³ / ₄	1 ³ / ₄	1	8	10d Common	4	10d Common	1305	1500	1630	1115
JUS36	18	2 ⁹ / ₁₆	5 ²⁶ / ₈₇	2	1	4	16d Common	4	16d Common	1015	1170	1220	1355
JUS38	18	2 ⁹ / ₁₆	6 ³ / ₄	2	1	6	16d Common	4	16d Common	1290	1485	1615	1355
JUS310	18	2 ⁹ / ₁₆	9 ¹ / ₈	2	1	8	16d Common	6	16d Common	1800	2070	2250	1980
JUS24-2	18	3 ¹ / ₈	3 ⁷ / ₁₆	2	1	4	16d Common	2	16d Common	780	900	965	325
JUS26-2	18	3 ¹ / ₈	5 ¹ / ₄	2	1	4	16d Common	4	16d Common	1015	1170	1220	1355
JUS28-2	18	3 ¹ / ₈	7 ¹ / ₈	2	1	6	16d Common	4	16d Common	1290	1485	1615	1355
JUS210-2	18	3 ¹ / ₈	9 ¹ / ₈	2	1	8	16d Common	6	16d Common	1800	2070	2250	1980
JUS214-2	18	3 ¹ / ₈	13 ¹ / ₈	2	1	12	16d Common	6	16d Common	2345	2700	2935	1980
JUS44	18	3 ⁵ / ₈	3 ¹ / ₄	2	1	4	16d Common	2	16d Common	780	900	965	325
JUS46	18	3 ⁵ / ₈	5	2	1	4	16d Common	4	16d Common	1015	1170	1220	1355
JUS48	18	3 ⁵ / ₈	6 ⁷ / ₈	2	1	6	16d Common	4	16d Common	1290	1485	1615	1355
JUS410	18	3 ⁵ / ₈	8 ⁷ / ₈	2	1	8	16d Common	6	16d Common	1800	2070	2250	1980
JUS414	18	3 ⁵ / ₈	12 ⁷ / ₈	2	1	12	16d Common	6	16d Common	2345	2700	2935	1980
JUS26-3	18	4 ⁵ / ₈	4 ¹ / ₂	2	1	4	16d Common	4	16d Common	1015	1170	1220	1355
JUS28-3	18	4 ⁵ / ₈	6 ³ / ₈	2	1	6	16d Common	4	16d Common	1290	1485	1615	1355
JUS210-3	18	4 ⁵ / ₈	8 ³ / ₈	2	1	8	16d Common	6	16d Common	1800	2070	2250	1980

For SI: 1 inch = 25.4 mm, 1 lbf = 4.45 N.

¹Allowable loads have been adjusted for load duration factors, CD, as shown, in accordance with the NDS. The allowable loads do not apply to loads of other durations, and are not permitted to be adjusted for other load durations. See Sections 4.1 and 4.2 for additional design and installation requirements.

²Allowable loads shown are for installations in wood members complying with Section 3.11.2. Wood members must also have a reference compression perpendicular to grain design value, F_{cz}, of 625 psi (4.31 MPa) or greater.

³See Section 3.11.3 for required fastener dimensions and mechanical properties.

⁴JUS hangers provide torsional resistance, up to a maximum joist depth of H + 1inch (H + 25.4 mm) where torsional resistance is defined as a moment not less than 75 pounds (334 N) times the depth of the joist at which the lateral movement of the top or bottom of the joist with respect to the vertical position of the joist is 0.125 inch (3.2 mm).

⁵Joist nails must be driven horizontally into the joist at an angle of 30- to 45-degrees from normal, such that they penetrate through the joist, and into the header.

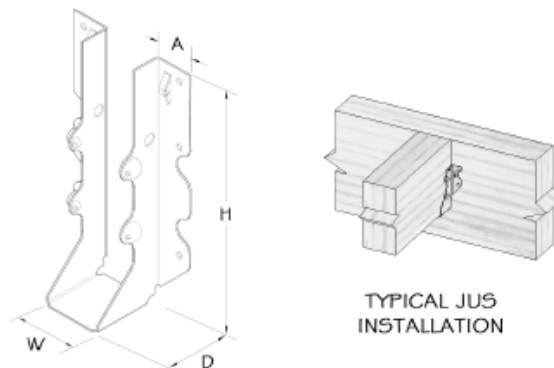

FIGURE 5—JUS SLANT NAIL JOIST HANGER

TABLE 7—MP_F MULTI-LATERAL PLATE TIE ALLOWABLE LOADS^{1,2,3,6}

STOCK NO.	STEEL GAGE	DIMENSIONS (inches)		INSTALL. CONFIG.	FASTENERS				DIR. OF LOAD	ALLOWABLE LOADS (lbs.)			
					Header/Stud		Joist/Plate			C _D = 1.0	C _D = 1.15	C _D = 1.25	C _D = 1.6
		W	L		Qty	Type	Qty	Type					
Installed in wood with a specific gravity of 0.50 or greater													
MP4F	20	3	4 1/4	Type 1	6	8d x 1 1/2	6	8d x 1 1/2	V	565	650	705	845
									H	565	650	705	845
				Type 2	6	8d x 1 1/2	6	8d x 1 1/2	V	565	650	705	845
									H	565	650	660	660
				Type 1	6	8d Common	6	8d Common	V	565	650	705	845
									H	565	650	705	845
				Type 2	6	8d Common	6	8d Common	V	565	650	705	845
									H	565	650	660	660
MP6F	20	3 3/4	4 1/4	Type 1	6	8d x 1 1/2	6	8d x 1 1/2	V	565	605	605	605
									H	565	605	605	605
				Type 2	6	8d x 1 1/2	6	8d x 1 1/2	V	565	605	605	605
									H	565	605	605	605
				Type 1	6	8d Common	6	8d Common	V	565	605	605	605
									H	565	605	605	605
				Type 2	6	8d Common	6	8d Common	V	565	605	605	605
									H	565	605	605	605
Installed in wood with a specific gravity from 0.42 to 0.49													
MP4F	20	3	4 1/4	Type 1	6	8d x 1 1/2	6	8d x 1 1/2	V	485	560	610	710
									H	485	560	610	710
				Type 2	6	8d x 1 1/2	6	8d x 1 1/2	V	485	560	610	710
									H	485	555	555	555
				Type 1	6	8d Common	6	8d Common	V	485	560	610	710
									H	485	560	610	710
				Type 2	6	8d Common	6	8d Common	V	485	560	610	710
									H	485	555	555	555
MP6F	20	3 3/4	4 1/4	Type 1	6	8d x 1 1/2	6	8d x 1 1/2	V	485	510	510	510
									H	485	510	510	510
				Type 2	6	8d x 1 1/2	6	8d x 1 1/2	V	485	510	510	510
									H	485	510	510	510
				Type 1	6	8d Common	6	8d Common	V	485	510	510	510
									H	485	510	510	510
				Type 2	6	8d Common	6	8d Common	V	485	510	510	510
									H	485	510	510	510

For **SI**: 1 inch = 25.4 mm, 1 lbf = 4.45 N.

¹Allowable loads have been adjusted for load duration factors, CD, as shown, in accordance with the NDS. The allowable loads do not apply to loads of other durations, and are not permitted to be adjusted for other load durations. See Sections 4.1 and 4.2 for additional design and installation requirements.

²Allowable loads shown are for installations in wood members complying with Section 3.11.2.

³See Section 3.11.3 for required fastener dimensions and mechanical properties.

⁴See Figure 6 for depiction of installation configurations.

⁵For direction of load: 'V' indicates a vertical (uplift) load; 'H' indicates a horizontal (shear) load within the plane of the MP_F plate.

⁶The MP_F may be installed over wood-based structural sheathing (as shown in Figure 6) having a maximum thickness of 1/2 inch (12.7 mm) without adversely affecting the tabulated allowable loads

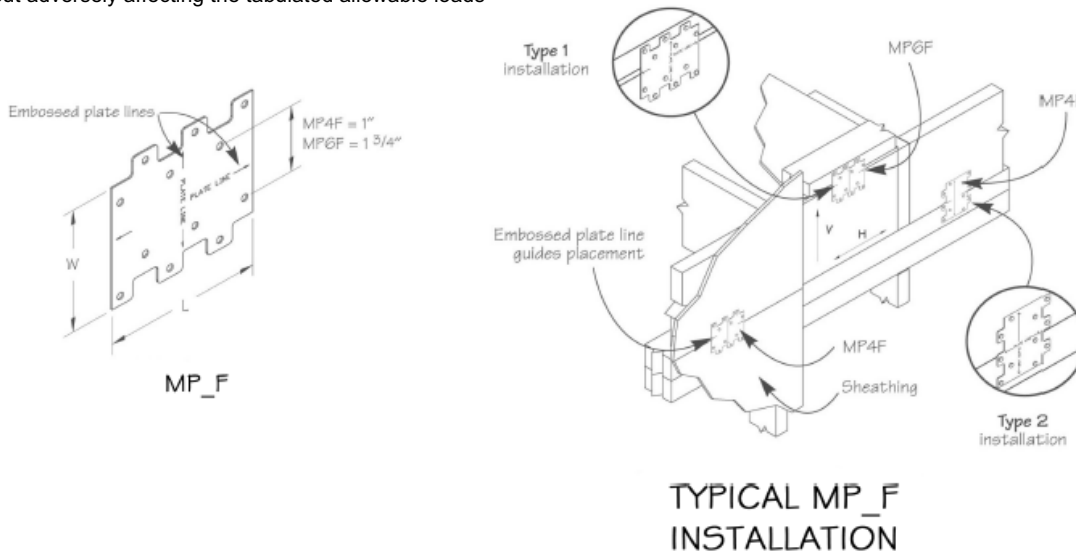

FIGURE 6—MP_F MULTI-LATERAL PLATE TIE

TABLE 8—PAU POST ANCHOR^{1,2,3,4,5,6}

STOCK NO.	STEEL GAGE			Dimensions (in.)			FASTENER SCHEDULE						ALLOWABLE LOADS (lbs)		
	Base	Stand-Off Plate	Washer	W	H	L	Nails		Bolts		Anchor Bolts		Bearing	Uplift	
							Qty	Type	Qty	Size	Qty	Size		100%	Nails
PAU44	12	16	10	3 ⁹ / ₁₆	5 ⁷ / ₁₆	3	12	16d Common	2	1/2	1	5/8	6775	2535	2265
PAU46	10	12	10	3 ⁹ / ₁₆	6	5	12	16d Common	2	1/2	1	5/8	13815	2535	2265
PAU66	10	12	10	5 ¹ / ₂	6	5	12	16d Common	2	1/2	1	5/8	16005	2380	2265
PAU88	12	12	3	7 ¹ / ₂	7 ³ / ₁₆	7 ¹ / ₁₆	14	16d Common	--	--	2	5/8	24900	3185	--
PAU88R	12	12	3	8 ¹ / ₁₆	6 ¹⁵ / ₁₆	7 ¹ / ₁₆	14	16d Common	--	--	2	5/8	24900	3185	--

For SI: 1 inch = 25.4 mm, 1 lbf = 4.45 N.

¹Allowable loads have been adjusted for load duration factors, CD, as shown, in accordance with the NDS. The allowable loads do not apply to loads of other durations, and are not permitted to be adjusted for other load durations. See Sections 4.1 and 4.2 for additional design and installation requirements.

²See Section 3.11.3 for required fastener dimensions and mechanical properties.

³Allowable loads shown are for installations in wood members complying with Section 3.11.2. Values apply only to parallel-to-grain loading of wood members.

⁴Allowable loads shown do not apply to the anchorage to concrete or masonry. Anchorage to concrete or masonry must be designed by a registered design professional in accordance with Section 4.1 of this report.

⁵The PAU Post Anchor has no moment or lateral capacity and should not be used in fixed post applications.

⁶Allowable nail loads and bolt loads are not permitted to be added together.

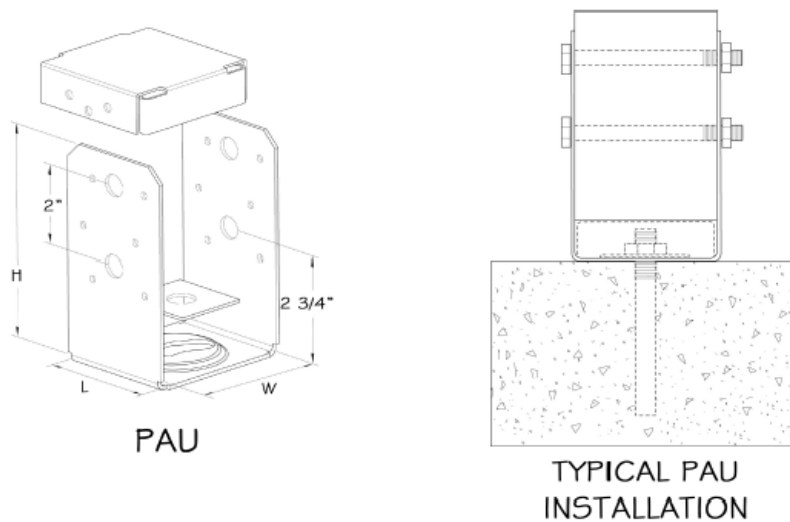

FIGURE 7—PAU POST ANCHOR

TABLE 9—RSPT STUD PLATE TIE ALLOWABLE LOADS^{1,2,3,4,5,6}

STOCK NO.	STEEL GAGE	DIMENSIONS (in.)		FASTENER SCHEDULE				ALLOWABLE LOADS (lbs)		
				Stud		Plate		Uplift	Lateral F ₁	Lateral F ₂
		W	H	Qty	Type	Qty	Type	C _D = 1.6	C _D = 1.6	C _D = 1.6
RSPT4	20	1 1/2	4 1/8	4	8d x 1 1/2	4	8d x 1 1/2	470	230	300
RSPT6	18	1 1/2	5 7/16	4	10d x 1 1/2	4	10d x 1 1/2	700	--	--
RSPT6-2	18	2 3/4	5 7/16	8	10d x 1 1/2	6	10d x 1 1/2	955	--	--

For SI: 1 inch = 25.4 mm, 1 lbf = 4.45 N.

¹Allowable loads have been adjusted for a load duration factor, CD, of 1.6, corresponding to a ten-minute load duration (i.e., wind or earthquake loading), in accordance with the NDS. The allowable loads do not apply to loads of other durations. See Sections 4.1 and 4.2 for additional design and installation requirements.

²See Section 3.11.3 for required fastener dimensions and mechanical properties.

³Allowable loads shown are for installations in wood members complying with Section 3.11.2.

⁴The 'Lateral F1' load direction is for lateral loading within the plane of the wall. The 'Lateral F2' load direction is for lateral loading perpendicular to the plane of the wall.

⁵Tabulated allowable loads are for a single connector. RSPT connectors should be installed in pairs at opposite sides of the stud to reduce eccentricity.

⁶Nails into pressure-treated bottom / sill plates must have a level of corrosion resistance that is compatible with the preservative treatment. See Section 3.11.4 of this report.

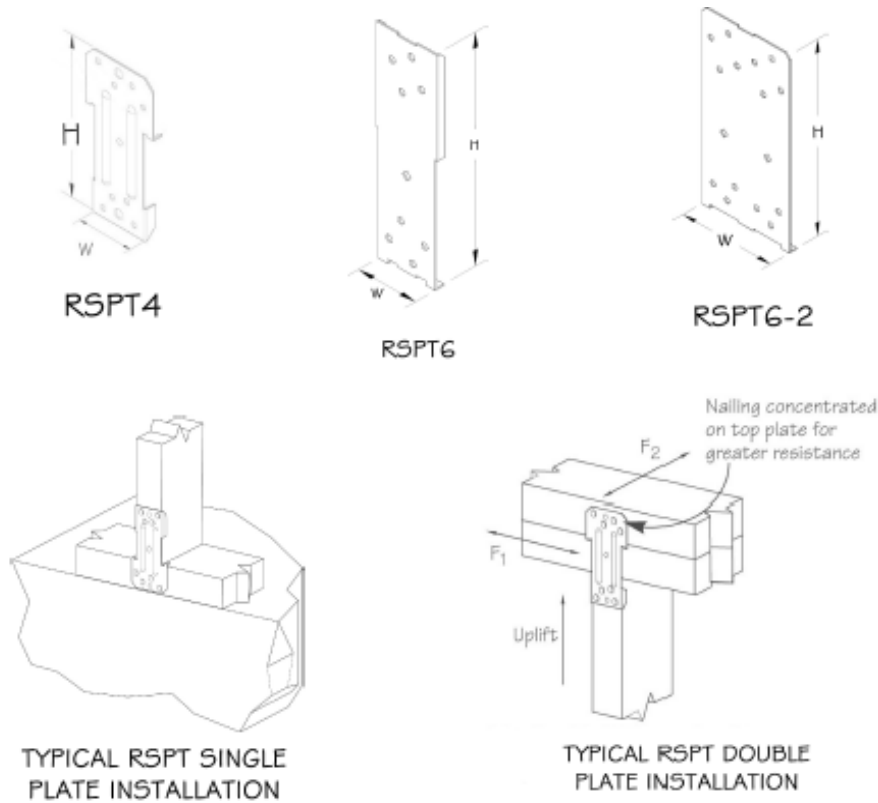

FIGURE 8—RSPT STUD PLATE TIE

TABLE 10—SPT AND SPTH STUD PLATE TIE ALLOWABLE LOADS^{1,2,3}

STOCK NO.	STEEL GAGE	DIMENSIONS (in.)		FASTENER SCHEDULE		ALLOWABLE UPLIFT LOADS (lbs.)
		W	H	Qty	Type	C _D = 1.6
SPT4	20	3 ⁹ / ₁₆	6 ⁷ / ₈	6	10d x 1 ¹ / ₂	945
SPT6	20	5 ⁹ / ₁₆	7 ⁵ / ₈	6	10d x 1 ¹ / ₂	945
SPT8	20	7 ⁵ / ₁₆	8 ¹ / ₂	6	10d x 1 ¹ / ₂	945
SPTH4	18	3 ⁹ / ₁₆	8 ⁵ / ₈	12	10d x 1 ¹ / ₂	1730
SPTH6	18	5 ⁹ / ₁₆	9 ³ / ₈	12	10d x 1 ¹ / ₂	1730
SPTH8	18	7 ⁵ / ₁₆	8 ¹ / ₂	12	10d x 1 ¹ / ₂	1730
SPTHW4	18	4 ¹ / ₁₆	8 ³ / ₈	12	10d x 1 ¹ / ₂	1290
SPTHW6	18	6 ¹ / ₁₆	9 ¹ / ₈	12	10d x 1 ¹ / ₂	1290

For SI: 1 inch = 25.4 mm, 1 lbf = 4.45 N.

¹Allowable loads have been adjusted for a load duration factor, CD, of 1.6, corresponding to a ten-minute load duration (i.e., wind or earthquake loading), in accordance with the NDS. The allowable loads do not apply to loads of other durations. See Sections 4.1 and 4.2 additional design and installation requirements.

²See Section 3.11.3 for required fastener dimensions and mechanical properties.

³Allowable loads shown are for installations in wood members complying with Section 3.11.2. Wood sill plates must also have a reference compression perpendicular to grain design value, F_c, of 625 psi (4.31 MPa) or greater.

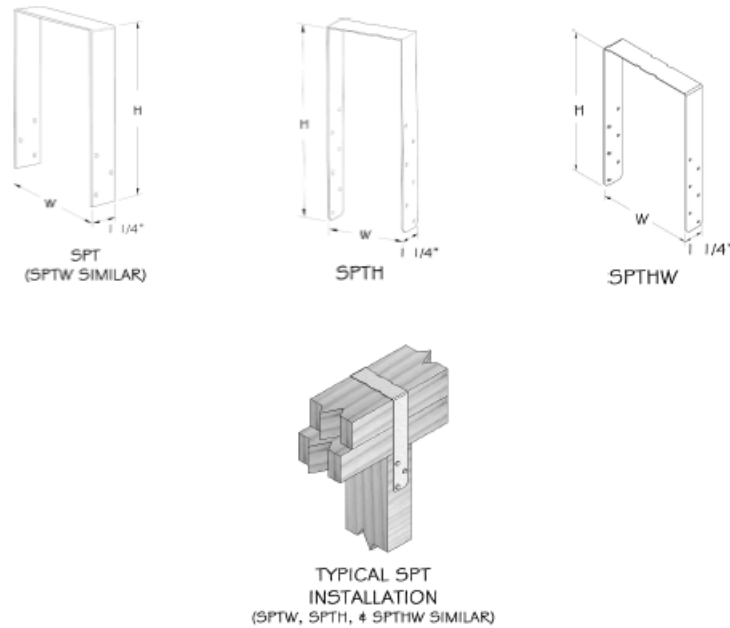

FIGURE 9—SPT AND SPTH STUD PLATE TIES

TABLE 11—THDH FACE MOUNT HANGER ALLOWABLE LOADS^{1,2,3,4}

STOCK NO.	STEEL GAGE	DIMENSIONS (in.)			FASTENER SCHEDULE				ALLOWABLE DESIGN LOADS IN DOUGLAS-FIR LARCH (lbs.)				ALLOWABLE DESIGN LOADS IN SPRUCE-PINE-FIR (lbs.)			
		W	H	D	Header		Joist		Download		Uplift		Download		Uplift	
					Qty	Type	Qty	Type	C _D = 1.0	C _D = 1.15	C _D = 1.25	C _D = 1.6	C _D = 1.0	C _D = 1.15	C _D = 1.25	C _D = 1.6
THDH26	12	1 ⁵ / ₈	5 ⁷ / ₁₆	5	20	16d Common	8	16d Common	3915	4505	4895	2340	3370	3880	4200	1965
THDH28	12	1 ⁵ / ₈	7 ³ / ₁₆	5	36	16d Common	12	16d Common	6770	7395	7395	4370	5830	6210	6210	3670
THDH210	12	1 ⁵ / ₈	9 ³ / ₁₆	5	46	16d Common	16	16d Common	8725	9580	9600	5400	6835	7385	7750	4535
THDH27925	12	2 ³ / ₄	9 ¹ / ₈	4	46	16d Common	12	16d Common	8260	8260	8260	3490	6935	6935	6935	2930
THDH27112	12	2 ³ / ₄	10 ⁷ / ₈	4	56	16d Common	14	16d Common	9845	9845	9845	5225	7655	8135	8270	4390
THDH2714	12	2 ³ / ₄	12 ¹ / ₄	4	66	16d Common	16	16d Common	9845	9845	9845	6810	8110	8270	8270	5835
THDH26-2	12	3 ⁷ / ₁₆	5 ³ / ₈	4	20	16d Common	8	16d Common	3915	4505	4795	2235	3370	3880	4030	1880
THDH28-2	12	3 ⁷ / ₁₆	7 ¹ / ₈	4	36	16d Common	10	16d Common	6535	7515	8025	2665	5635	6480	6740	2240
THDH210-2	12	3 ⁷ / ₁₆	9 ¹ / ₈	4	46	16d Common	12	16d Common	8260	8260	8260	3490	6935	6935	6935	2930
THDH3210	12	3 ³ / ₁₆	9 ³ / ₈	4	46	16d Common	12	16d Common	8260	8260	8260	3490	6935	6935	6935	2930
THDH3212	12	3 ³ / ₁₆	10 ⁵ / ₈	4	56	16d Common	14	16d Common	9845	9845	9845	5960	8270	8270	8270	5105
THDH46	12	3 ⁹ / ₁₆	5 ³ / ₈	4	20	16d Common	8	16d Common	3915	4505	4895	2605	3370	3880	4215	2190
THDH48	12	3 ⁹ / ₁₆	7 ¹ / ₈	4	36	16d Common	10	16d Common	6535	7515	7835	3185	5635	6480	6580	2675
THDH410	12	3 ⁹ / ₁₆	9 ¹ / ₈	4	46	16d Common	12	16d Common	8260	9010	9010	3970	7120	7570	7570	3335
THDH412	12	3 ⁹ / ₁₆	10 ¹ / ₂	4	56	16d Common	14	16d Common	9845	9845	9845	5225	8270	8270	8270	4390
THDH414	12	3 ⁹ / ₁₆	13 ¹ / ₁₆	4	66	16d Common	16	16d Common	9845	9845	9845	6810	8270	8270	8270	5835
THDH26-3	12	5 ¹ / ₈	5 ⁷ / ₁₆	4	20	16d Common	8	16d Common	3915	4505	4795	2235	3370	3880	4030	1880
THDH28-3	12	5 ¹ / ₈	7 ³ / ₁₆	4	36	16d Common	12	16d Common	6770	7785	8025	2665	5830	6705	6740	2240
THDH210-3	12	5 ¹ / ₈	9 ³ / ₁₆	4	46	16d Common	16	16d Common	8725	9855	9855	4565	7520	8275	8275	3835
THDH212-3	12	5 ¹ / ₈	11 ³ / ₁₆	4	56	16d Common	20	16d Common	9935	9935	9935	5180	8345	8345	8345	4355
THDH214-3	12	5 ¹ / ₈	13 ³ / ₁₆	4	66	16d Common	22	16d Common	11645	11645	11645	5795	9780	9780	9780	4865
THDH610	12	5 ¹ / ₂	9	4	46	16d Common	16	16d Common	8725	9855	9855	4565	7520	8275	8275	3835
THDH612	12	5 ¹ / ₂	11	4	56	16d Common	20	16d Common	9935	9935	9935	5180	8345	8345	8345	4355
THDH614	12	5 ¹ / ₂	13	4	66	16d Common	22	16d Common	11645	11645	11645	5795	9780	9780	9780	4865
THDH6710	12	6 ¹ / ₈	8 ¹³ / ₁₆	4	46	16d Common	12	16d Common	8260	8260	8260	3490	6935	6935	6935	2930
THDH6712	12	6 ¹ / ₈	10 ¹³ / ₁₆	4	56	16d Common	14	16d Common	9845	9845	9845	5225	8270	8270	8270	4390
THDH6714	12	6 ¹ / ₈	12 ¹³ / ₁₆	4	66	16d Common	16	16d Common	9845	9845	9845	6810	8270	8270	8270	5835
THDH7210	12	7 ¹ / ₄	9	4	46	16d Common	12	16d Common	8260	9010	9010	3970	7120	7570	7570	3335
THDH7212	12	7 ¹ / ₄	10 ¹ / ₂	4	56	16d Common	14	16d Common	9845	9845	9845	5225	8270	8270	8270	4390
THDH7214	12	7 ¹ / ₄	12 ¹ / ₄	4	66	16d Common	16	16d Common	9845	9845	9845	6810	8270	8270	8270	5835

For SI: 1 inch = 25.4 mm, 1 lbf = 4.45 N.

¹Allowable loads have been adjusted for load duration factors, CD, as shown, in accordance with the NDS. The allowable loads do not apply to loads of other durations, and are not permitted to be adjusted for other load durations. See Sections 4.1 and 4.2 for additional design and installation requirements.

²Allowable loads shown are for installations in wood members complying with Section 3.11.2.

³See Section 3.11.3 for required fastener dimensions and mechanical properties.

⁴THDH hangers provide torsional resistance, up to a maximum joist depth of H + 1 inch (H + 25.4 mm) where torsional resistance is defined as a moment not less than 75 pounds (334 N) times the depth of the joist at which the lateral movement of the top or bottom of the joist with respect to the vertical position of the joist is 0.125 inch (3.2 mm).

⁵Joist nails must be driven horizontally into the joist at an angle of 30- to 45-degrees from normal, such that they penetrate through the joist, and into the header.

⁶Allowable design loads given for installations with Douglas fir-Larch members are based on an assumed specific gravity of 0.50 for the purpose of fastener design, and an assumed reference compression perpendicular to grain design value, F_{cz}, of 625 psi (4.31 MPa).

⁷Allowable design loads given for installations with Spruce-Pine-Fir members are based on an assumed specific gravity of 0.42 for the purpose of fastener design, and an assumed reference compression perpendicular to grain design value, F_{cz}, of 425 psi (2.93 Mpa).

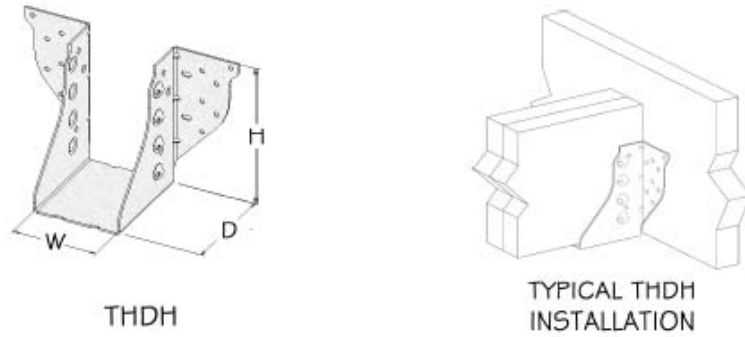

FIGURE 10—THDH FACE MOUNT HANGER

TABLE 12—STEEL TYPE, STRENGTH AND CORROSION RESISTANCE

Product	Steel	Coating
CLPBF Butterfly Hanger	ASTM A 653, SS designation, Grade 33	G90 ¹
CMST Coil Strap	ASTM A 653, SS designation, Grade 50, Class 1	G90 ¹
HCPRS Hurricane/Seismic Anchor	ASTM A 653, SS designation, Grade 33	G90 ¹
HUS Slant Nail Joist Hanger	ASTM A 653, SS designation, Grade 33	G90 ¹ , G185 ¹
JUS Slant Nail Joist Hanger	ASTM A 653, SS designation, Grade 33	G90 ¹ , G185 ¹
MP_F Multi-Lateral Plate Tie	ASTM A 653, SS designation, Grade 33	G90 ¹ , G185 ¹
PAU Post Anchor	Nos. 10, 12, 16 Ga. Material: ASTM A 653, SS designation, Grade 33 Nos. 3, 10 Ga. material: ASMT A 36	G90 ¹ , G185 ¹ Painted
RSPT Stud Plate tie	ASTM A 653, SS designation, Grade 33	G90 ¹ , G185 ¹
SPT and SPTH Stud Plate Ties	ASTM A 653, SS designation, Grade 33	G90 ¹ , G185 ¹
THDH Face Mount Hanger	ASTM A 653, SS designation, Grade 33	G90 ¹ , G185 ¹

For SI: 1 lbf/in² = 6.89 kPa.

¹Corrosion protection is a zinc coating in accordance with ASTM A 653.