

ICC-ES Evaluation Report

ESR-1280*

Reissued May 1, 2011

This report is subject to renewal in two years.www.icc-es.org | (800) 423-6587 | (562) 699-0543

A Subsidiary of the International Code Council®

DIVISION: 06 00 00—WOOD, PLASTICS AND COMPOSITES
Section: 06 05 23—Wood, Plastic, and Composite Fastenings

REPORT HOLDER:

UNITED STEEL PRODUCTS COMPANY
14305 SOUTHCROSS DRIVE, SUITE 200
BURNSVILLE, MINNESOTA 55306
(952) 898-8772
www.uspconnectors.com
info@uspconnectors.com

EVALUATION SUBJECT:**USP STRUCTURAL CONNECTORS****1.0 EVALUATION SCOPE****Compliance with the following codes:**

- 2009 and 2006 *International Building Code*® (IBC)
- 2009 and 2006 *International Residential Code*® (IRC)

Property evaluated:

Structural

2.0 USES

The USP structural connectors described in this report (see Table 1 for a complete listing) are used for connecting wood framing members in accordance with Section 2304.9.3 of the IBC. They may also be used in structures regulated under the IRC when an engineered design is submitted in accordance with IRC Section R301.1.3.

3.0 DESCRIPTION**3.1 C Post Cap:**

The C Post Cap is designed to be installed on top of nominal dimension or rough sawn lumber posts for the attachment of solid-sawn beams. The C Post Cap is cold-formed from No. 18 gage steel and is prepunched for 16d common nails. See Table 4 and Figure 1 for product dimensions, fastener schedule, allowable loads, and a typical installation detail.

3.2 D Post Anchor:

The D Post Anchor is designed to secure nominal dimensioned or rough sawn posts to wood surfaces. The D Post Anchor is cold-formed from No. 18 gage steel and is prepunched for 16d common nails. See Table 5 and Figure

2 for product dimensions, fastener schedule, allowable loads, and a typical installation detail.

3.3 HH Header Hanger:

The HH Header Hanger is designed to support wood headers over door or window openings. The HH Header Hanger is cold-formed from No. 16 gage steel and is prepunched for 16d common nails. See Table 6 and Figure 3 for product dimensions, fastener schedule, allowable loads, and a typical installation detail.

3.4 HL Light Gage Purlin Hanger:

The HL Light Gage Purlin Hanger is designed as a top-mount-type hanger, flanged at right angles to permit direct face nailing to the joist and header. The HL Light Gage Purlin Hanger is cold-formed from No. 18 gage steel and is prepunched for 16d common nails into the header, and in the case of model HL214, 10d-by-1¹/₂ nails into the joist. See Table 7 and Figure 4 for product dimensions, fastener schedule, allowable loads, and a typical installation detail.

3.5 KHHB Hangers:

The KHHB Hangers are top-mount hangers designed to join together, glued-laminated timber, to supports. The KHHB Hangers are formed from 7 gage steel and are prepunched for NA25 nails. See Table 8 and Figure 5 for product dimensions, fastener schedule, allowable loads, and a typical installation detail.

3.6 KEG, KMEG and KLEG Glulam Beam Hangers:

The KEG, KMEG and KLEG hangers are designed to connect glued-laminated beams together, using ³/₄- or 1-inch-diameter (19 or 25.4 mm) bolts. The U-straps and the KLEG and KMEG top flanges are manufactured from minimum No. 7 gage hot-rolled steel plate. The KEG top flanges are manufactured from No. 3 gage hot-rolled steel plate. All U-straps are welded to the flange component utilizing factory welds. See Table 9 and Figure 6 for product dimensions, fastener schedule, allowable loads, and a typical installation detail.

3.7 KF Panel Hanger:

The KF Panel Hanger is designed to fasten joist ends to the supporting construction. The KF Panel Hanger is cold-formed from No. 18 gage steel and is prepunched for 10d common nails into the header and 10d-by-1¹/₂ nails into the joist. See Table 10 and Figure 7 for product dimensions, fastener schedule, allowable loads, and a typical installation detail.

3.8 KHST Strap Ties:

The KHST Strap Ties are designed to connect various wood framing members together to resist tensile forces.

***Revised June 2011**

ICC-ES Evaluation Reports are not to be construed as representing aesthetics or any other attributes not specifically addressed, nor are they to be construed as an endorsement of the subject of the report or a recommendation for its use. There is no warranty by ICC Evaluation Service, LLC, express or implied, as to any finding or other matter in this report, or as to any product covered by the report.



The KHST straps are fastened with bolts. The KHST straps are fabricated from minimum No. 7 or No. 3 gage hot-rolled steel plate and are installed with either $\frac{5}{8}$ -inch-diameter (15.9 mm) or $\frac{3}{4}$ -inch-diameter (19.0 mm) bolts. See Table 11 and Figure 9 for product dimensions, fastener schedule, and allowable loads of the KHST.

3.9 KGH Floor Girder Hanger:

The KGH Floor Girder Hanger is designed to support girders and beams, and transfer loads onto a concrete or masonry foundation wall. The KGH Floor Girder Hanger is cold-formed from No. 12 gage steel, and consists of a U-shaped strap factory-welded to a top-flange angle. The U-shaped strap is prepunched for 16d common nails. See Table 12 and Figure 10 for product dimensions, fastener schedule, allowable loads, and a typical installation detail.

3.10 KGLS, KGLST, KHGLS and KHGLST Glulam Saddle Hangers:

The KGLS and KHGLS Glulam Saddle Hangers are designed to connect glued-laminated or sawn lumber beams to a supporting member. The KGLST and KHGLST Glulam Saddle Hangers are designed to connect glued-laminated beams to a girder, and to transfer wind and seismic forces in drag strut applications. The U-shaped saddles are fabricated from minimum No. 7 gage hot-rolled steel plate, and the top flanges are fabricated from No. 3 gage hot-rolled steel plate. The saddles are connected to the top flange component and the side straps are factory-welded to each of the saddles of the KGLST and KHGLST hangers. The KGLS, KGLST, KHGLS and KHGLST Glulam Saddle Hangers are prepunched for NA25 nails. Additionally, the side straps and top flange on the KGLST and KHGLST have holes for installing $\frac{3}{4}$ -inch-diameter (19 mm) bolts. See Table 13 and Figure 11 for product dimensions, fastener schedule, allowable loads, and a typical installation detail.

3.11 KGLT and KHGLT Glulam Beam Hangers:

The KGLT and KHGLT Glulam Beam Hangers are designed to connect glued-laminated or sawn lumber beams to a supporting member. The U-shaped saddle is fabricated from minimum No. 7 gage hot-rolled steel plate and the top flange is fabricated from No. 3 gage hot-rolled steel plate. The saddle is factory-welded to the top flange component. The KGLT and KHGLT Glulam Beam Hangers are prepunched for NA25 nails. See Table 14 and Figure 12 for product dimensions, fastener schedule, allowable loads, and a typical installation detail.

3.12 KHC Hinge Connector and KHCST / KHCSTR Seismic Straps:

The KHC Hinge Connector is designed to support glued-laminated beams having the same width and top elevation, end-to-end. The connectors consist of steel top and bottom plates factory-welded to steel side plates forming a rectangular assembly. The side plates of the connector have holes for installing the required bolts. The KHCST and KHCSTR Seismic Strap is used as an independent part to transfer axial tension induced by wind or seismic loading from one beam to the other, and is used in conjunction with the KHC to provide additional resistance to horizontal loads when installed in pairs. The KHC Hinge Connector side plates and KHCST / KHCSTR Seismic Strap are fabricated from minimum No. 7 or No. 3 gage hot-rolled steel plate. The KHC Hinge Connector top and bottom plates are manufactured from $\frac{3}{4}$ -inch- (19 mm), 1-inch- (25 mm), $1\frac{1}{4}$ -inch- (32 mm) or $1\frac{1}{2}$ -inch-thick (38 mm) hot-rolled steel plate. The KHC Hinge Connector and KHCST / KHCSTR Seismic Strap are installed with $\frac{3}{4}$ -inch-diameter (19 mm) bolts. See

Table 15 and Figure 13 for product dimensions, fastener schedule, allowable loads, and a typical installation detail.

3.13 KSA and KHA Connector Straps:

The KSA and KHA Connector Straps are designed to transfer tension loads between two opposing purlins/joists across the supporting beam. The KSA Connector Strap is cold-formed from No. 12 gage hot-rolled steel plate that is prepunched for either 16d common nails, or $\frac{1}{2}$ -inch or $\frac{3}{4}$ -inch-diameter (12.7 or 19 mm) bolts. The KHA Connector Strap is cold-formed from No. 3 gage hot-rolled steel plate that is prepunched for $\frac{3}{4}$ -inch-diameter (19 mm) bolts. See Table 16 and Figure 14 for product dimensions, fastener schedule, allowable loads, and typical installation details.

3.14 KVB and KVBI Knee Brace:

The KVB and KVBI Knee Brace is designed to provide lateral support of the bottom of deep beams by attaching to purlins installed on each side of the beam. The KVB and KVBI Knee Brace is cold-formed from No. 12 gage steel and is prepunched for either 10d common or NA25 nails. See Table 17 and Figure 15 for product dimensions, fastener schedule, allowable loads, and a typical installation detail.

3.15 PHG Panel Hanger:

The PHG Panel Hanger is designed to fasten joist ends to the supporting wood member. The side flanges of the hanger are turned inward toward the joist to embed into the joist during installation. The PHG Panel Hanger is cold-formed from No. 18 gage steel and is prepunched for 8d or 10d common nails. See Table 18 and Figure 16 for product dimensions, fastener schedule, allowable loads, and a typical installation detail.

3.16 SCA Stair Angle:

The SCA Stair Angle is designed to be used to attach stair treads to stringers. The SCA Stair Angle is cold-formed from No. 12 gage steel and is prepunched for $\frac{1}{4}$ -inch-diameter-by- $1\frac{1}{2}$ -inch-long (6.4 by 37 mm) lag screws. See Table 19 and Figure 17 for product dimensions, fastener schedule, allowable loads, and a typical installation detail.

3.17 SUH Joist Hanger:

The SUH Joist Hanger is designed as a face-mount hanger to support nominal dimension joists. The SUH Joist Hanger is cold-formed from No. 16 gage steel. The SUH Joist Hanger has prongs in the header flanges to temporarily position the hanger on the header. The hanger is prepunched for 10d common or 16d common nails into the header and 10d-by- $1\frac{1}{2}$, 10d common, or 16d common nails into the joist. See Table 20 and Figure 18 for product dimensions, fastener schedule, allowable loads, and a typical installation detail.

3.18 TFI Top Mount Hanger:

The TFI Top Mount Hanger is designed as a top-flange-mounted hanger to support prefabricated wood I-joists. The TFI Top Mount Hanger is cold-formed from No.16 gage steel and is prepunched for 16d common nails into the header and 10d-by- $1\frac{1}{2}$ nails into the I-joist. See Table 21 and Figure 19 for product dimensions, fastener schedule, allowable loads, and a typical installation detail.

3.19 Materials:

3.19.1 Steel: The specific types of steel and corrosion protection for each product described in this report are shown in Table 22. Minimum steel base-metal thicknesses for the different gages are shown in Table 2.

3.19.2 Wood: Wood members must be sawn lumber or structural glued laminated timber with a minimum specific gravity of 0.50, or approved structural engineered lumber (structural composite lumber, alternative strand lumber, or prefabricated wood I-joists) with a minimum equivalent specific gravity of 0.50, unless otherwise noted in the applicable table within this report. Wood members must have a moisture content not exceeding 19 percent (16 percent for structural engineered lumber), except as noted in Section 4.1. For connectors installed with nails or lag screws, the thickness of each wood member must be sufficient such that the specified fasteners do not protrude through the opposite side of the member, unless otherwise permitted in the applicable table within this report. For installations in structural engineered lumber, minimum allowable nail or screw spacing and end distance, as specified in the applicable evaluation report for the structural engineered lumber, must be met. Refer to Section 3.19.3.4 for issues related to treated wood.

3.19.3 Fasteners: Required fastener types and sizes for use with the USP structural connectors described in this report are specified in this section and in Tables 4 through 21.

3.19.4 Bolts: At a minimum, bolts must comply with ASTM A 307 and must have a minimum bending yield strength of 45,000 lbf/in² (310 MPa). Bolt diameters must be as specified in the applicable tables of this report.

3.19.4.1 Lag Screws: Lag screws must comply with ANSI/ASME Standard B18.2.1, and must have minimum dimensions and bending yield strengths as specified in Table 3.

3.19.4.2 Nails: Nails used for connectors described in this report must comply with material requirements, physical properties, tolerances, workmanship, protective coating and finishes, and packaging and package marking requirements specified in ASTM F 1667, and must have lengths, diameters and bending yield strengths as shown in Table 3.

3.19.4.3 Use in Treated Wood: Connectors and fasteners used in contact with preservative-treated or fire-retardant-treated wood must comply with 2006 or 2009 IBC Section 2304.9.5 or 2006 or 2009 IRC Section 317.3, as applicable. The lumber treater or the holder of this report (United Steel Products Company), or both, should be contacted for recommendations on the appropriate level of corrosion resistance to specify for the connectors, as well as the connection capacities of the fasteners used with the specific proprietary preservative-treated or fire-retardant-treated lumber.

4.0 DESIGN and INSTALLATION

4.1 Design:

The allowable loads in Tables 4 through 21 are based on allowable stress design. The use of the allowable load values for the products listed in Table 1 report must comply with all applicable requirements and conditions specified in this report. Tabulated allowable loads are for normal duration and short duration, based on load duration factors, C_D , in accordance with Section 10.3.2 of the NDS, as indicated in Tables 4 through 21 of this report. No further increases are permitted for load durations other than those specified. Tabulated allowable loads are for connections in wood seasoned to a maximum moisture content of 19 percent (16 percent for engineered wood products) or less, used under continuously dry conditions and where sustained temperatures are limited to 100°F (37.8°C) or less. When connectors are installed in wood having a moisture content greater than 19 percent

(16 percent for engineered wood products), or where the in-service moisture content is expected to exceed this value, the applicable wet service factor, C_M , must be applied. Unless otherwise noted in the tables of this report, the applicable wet service factor, C_M , is as specified in the NDS for lateral loading of dowel-type fasteners. When connectors are installed in wood that will experience sustained exposure to temperatures exceeding 100°F (37.7°C), the allowable loads in this evaluation report must be adjusted by the temperature factor, C_t , specified in Section 10.3.4 of the NDS. Group action factor, C_g , has been accounted for, in accordance with Section 10.3.6 of the NDS, in the tabulated allowable loads, where applicable. For connectors installed with bolts or lag screws, minimum edge distances and end distances within the wood members must be met, such that the geometry factor, C_{Δ} , is 1.0, in accordance with NDS Section 11.5.1. Connected wood members must be checked for load-carrying capacity at the connection in accordance with NDS Section 10.1.2.

4.2 Installation:

Installation of the connectors must be in accordance with this evaluation report and the manufacturer's published installation instructions. Bolts must be installed in accordance with NDS Section 11.1.2. Lag screws must be installed in accordance with NDS Section 11.1.3.

4.3 Special Inspection:

4.3.1 IBC: Periodic special inspection is required for installation of connectors described in this report that are designated as components of the seismic-force-resisting system for structures in Seismic Design Categories C, D, E or F in accordance with IBC Section 1707.3 or 1707.4, with the exception of those structures that qualify under the Exceptions to Section 1704.1.

4.3.2 IRC: Special inspections are not required for connectors used in structures regulated under the IRC.

5.0 CONDITIONS OF USE

The USP Structural Connectors described in this report comply with, or are suitable alternatives to what is specified in, those codes listed in Section 1.0 of this report, subject to the following conditions:

- 5.1** The connectors are manufactured, identified and installed in accordance with this report and the manufacturer's published installation instructions. A copy of the manufacturer's published installation instructions must be available at the jobsite at all times during installation. In the event of a conflict between this report and the manufacturer's published installation instructions, this report governs.
- 5.2** Calculations showing compliance with this report must be submitted to the code official. The calculations must be prepared by a registered design professional where required by the statutes of the jurisdiction in which the project is to be constructed.
- 5.3** Connected wood members and fasteners must comply with Sections 3.19.2 and 3.19.3, respectively.
- 5.4** Adjustment factors noted in Section 4.1 of this report and the applicable codes must be considered, where applicable.
- 5.5** Connectors identified in Table 1 as being manufactured under a quality control program with third-party inspections are manufactured at the designated facilities under a quality control program with inspections by PFS Corporation (AA-652).

6.0 EVIDENCE SUBMITTED

- 6.1** Manufacturer's published installation instructions and descriptive literature.
- 6.2** Data in accordance with the ICC-ES Acceptance Criteria for Joist Hangers and Similar Devices (AC13), dated October 2010.

index evaluation report for United Steel Products Company ([ESR-2685](#)), and by one or more of the following designations: USP, or United Steel Products Company. Labels on connectors identified in Table 1 as being manufactured under a quality control program with third-party inspections also bear the name of the third-party inspection agency (PFS Corporation).

7.0 IDENTIFICATION

Each connector described in this report is identified by the product model (stock) number, the number of the ICC-ES

TABLE 1—CROSS REFERENCE OF PRODUCT NAMES WITH APPLICABLE REPORT SECTIONS, TABLES AND FIGURES

PRODUCT NAME	REPORT SECTION	TABLE NO.	FIGURE NO.
C Post Cap	3.1	4	1
D Post Anchor	3.2	5	2
HH Header Hanger	3.3	6	3
HL Light Gage Purlin Hanger	3.4	7	4
KEG Glulam Beam Hanger ¹	3.6	9	6
KF Panel Hanger	3.7	10	7
KGH Floor Girder Hanger ¹	3.9	12	10
KGLS Glulam Saddle Hangers ¹	3.10	13	11
KGLST Glulam Saddle Hanger ¹	3.10	13	11
KGLT Glulam Beam Hanger ¹	3.11	14	12
KHC Hinge Connector ¹	3.12	15	13
KHCST and KHCSTR Seismic Strap ¹	3.12	15	13
KHGLS Glulam Saddle Hanger ¹	3.10	13	11
KHGLST Glulam Saddle Hanger ¹	3.10	13	11
KHGLT Glulam Beam Hanger ¹	3.11	14	12
KHHB Glulam Hangers	3.5	8	5
KHSA Connector Strap	3.13	16	14
KHST Strap Tie	3.8	11	9
KLEG Glulam Beam Hanger ¹	3.6	9	6
KMEG Glulam Beam Hanger ¹	3.6	9	6
KSA Connector Strap	3.13	16	14
KVB and KVBI Knee Brace	3.14	17	15
PHG Panel Hanger	3.15	18	16
SCA Stair Angle	3.16	19	17
SUH Joist Hanger	3.17	20	18
TFI Top Mount Hanger	3.18	21	19

¹Products are manufactured at the USP manufacturing facilities in Largo, Florida; Livermore, California; and Montgomery, Minnesota, under a quality control program with third-party inspections by PFS Corporation (AA-652).

TABLE 2—STANDARD STEEL GAGE EQUIVALENT DIMENSIONS

GAGE NO.	DESIGN BASE-METAL THICKNESS (inch)	MINIMUM BASE-METAL THICKNESS ¹ (inch)
18	0.0460	0.044
16	0.0580	0.055
14	0.0740	0.070
12	0.1040	0.099
7	0.1800	0.171
3	0.2500	0.240

For **SI**: 1 inch = 25.4 mm.

¹Minimum base-metal thickness as specified by the manufacturer.

TABLE 3—FASTENER SIZES AND BENDING YIELD STRENGTHS²

FASTENER DESIGNATION ¹	FASTENER LENGTH (inch)	SHANK DIAMETER (inch)	MINIMUM REQUIRED F_{yb} (lbf/in ²)
8d common	2.5	0.131	100000
10d common	3.0	0.148	90000
10d-by-1 ¹ / ₂	1.5	0.148	90000
16d sinker	3.25	0.148	90000
16d-by-2 ¹ / ₂	2.5	0.162	90000
16d common	3.5	0.162	90000
NA25	3.0	0.250	70000
¹ / ₄ " x 1 ¹ / ₂ " lag screw	1.5	0.250	70000
¹ / ₂ " dia. bolt	Varies	0.500	45000
⁵ / ₈ " dia. bolt	Varies	0.625	45000
³ / ₄ " dia. bolt	Varies	0.750	45000
1" dia. bolt	Varies	1.00	45000

For **SI**: 1 inch = 25.4 mm, 1 lbf/in² = 6.89 kPa.

¹Corresponding to fastener designations in Tables 4 through 26.

²Fasteners must have lengths, diameters and minimum bending yield strengths, F_{yb} , as shown.

TABLE 4—C POST CAP ALLOWABLE LOADS^{1,2,3}

STOCK NO.	STEEL GAGE	DIMENSIONS (inches)						FASTENER SCHEDULE			ALLOWABLE LOADS (lbs)	
		W1	W2	L1	L2	H1	H2	Qty.		Nail Type	Uplift	Lateral (F1 & F2)
								Post	Beam		C _D = 1.6	C _D = 1.6
C44	18	3 ⁹ / ₁₆	3 ⁹ / ₁₆	3 ¹ / ₄	3 ¹ / ₄	2 ⁷ / ₈	2 ⁷ / ₈	6	6	16d Common	1000	1225
C44R	18	4	4	3 ¹ / ₄	3 ¹ / ₄	2 ⁵ / ₈	2 ⁵ / ₈	8	8	16d Common	1000	1225
C46	18	3 ⁹ / ₁₆	5 ¹ / ₂	3 ³ / ₈	5 ¹ / ₄	2 ⁹ / ₁₆	2 ⁵ / ₈	6	10	16d Common	1000	1225
C46R	18	4	6	3 ¹ / ₄	5 ¹ / ₄	2 ³ / ₄	2 ³ / ₄	8	10	16d Common	1000	1225
C66	18	5 ¹ / ₂	5 ¹ / ₂	5 ¹ / ₂	5 ¹ / ₄	2 ⁷ / ₈	2 ⁷ / ₈	12	12	16d Common	1295	2190
C66R	18	6	6	5 ¹ / ₄	5 ¹ / ₄	2 ¹³ / ₁₆	2 ¹³ / ₁₆	10	10	16d Common	1090	2190
C88	18	7 ¹ / ₂	7 ¹ / ₂	7 ³ / ₈	7 ³ / ₈	5	5	16	16	16d Common	1125	2525

For SI: 1 inch = 25.4 mm, 1 lb. = 4.45 N.

¹Allowable loads have been adjusted for a load duration factor, C_D, of 1.6, corresponding to a ten-minute load duration (i.e., wind or earthquake loading), in accordance with the NDS. The allowable loads do not apply to loads of other durations. See Sections 4.1 and 4.2 for design and installation requirements.

²See Section 3.19.3 and Table 3 for required fastener dimensions and mechanical properties.

³Allowable loads shown are for installations in wood members complying with Section 3.19.2.

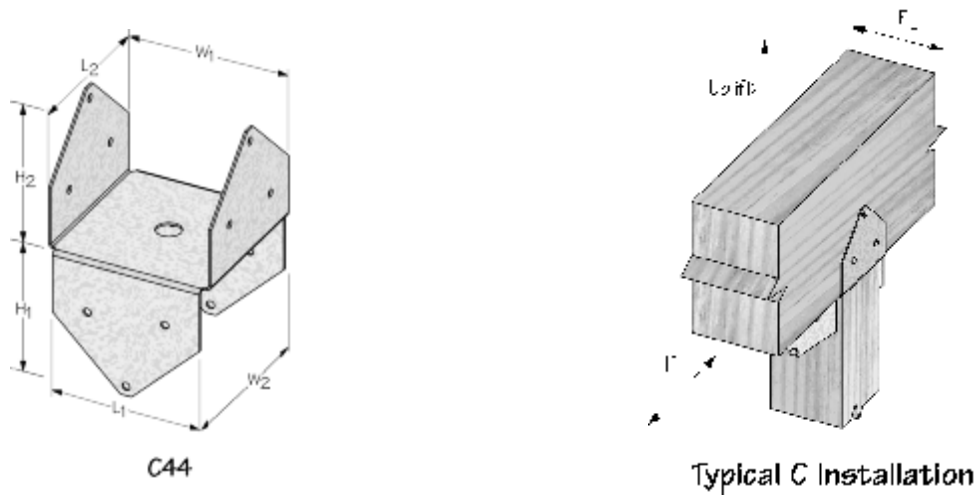

FIGURE 1—C POST CAP

TABLE 5—D POST ANCHOR ALLOWABLE LOADS^{1, 2, 3, 4}

STOCK NO.	STEEL GA.	DIMENSIONS (inches)			FASTENER SCHEDULE			ALLOWABLE LOADS (lbs)		
		W	H	L	Qty.		Nail Type	F1	F2	Uplift
					Post	Beam		C _D = 1.6	C _D = 1.6	C _D = 1.6
D44-TZ	18	3 ⁹ / ₁₆	2 ¹ / ₂	3 ³ / ₈	8	4	16d Common	875	875	715
D44R	18	4	3	3 ³ / ₄	8	4	16d Common	875	875	715
D46	18	3 ⁹ / ₁₆	3	5 ³ / ₈	10	5	16d Common	1020	1095	715
D66	18	5 ¹ / ₂	3	5 ³ / ₈	10	5	16d Common	1020	1095	715
D66R	18	6	3	5 ³ / ₈	10	5	16d Common	1020	1095	715
D88	18	7 ¹ / ₂	3	7 ³ / ₈	12	5	16d Common	1020	1095	715

For SI: 1 inch = 25.4 mm, 1 lbf = 4.45 N.

¹Allowable loads have been adjusted for a load duration factor, C_D, of 1.6, corresponding to a ten-minute load duration (i.e., wind or earthquake loading), in accordance with the NDS. The allowable loads do not apply to loads of other durations. See Sections 4.1 and 4.2 for design and installation requirements.

²See Section 3.19.3 and Table 3 for required fastener dimensions and mechanical properties.

³Allowable loads shown are for installations in wood members complying with Section 3.19.2.

⁴The supporting beam must have a minimum dimension of 3.5 inches (89 mm) in the direction parallel to the nail axis.

⁵When connectors are installed in wood having a moisture content greater than 19 percent (16 percent for engineered wood products), or where the moisture content is expected to exceed this value at any time while in service, the allowable uplift load must be adjusted by the applicable wet service factor, C_M, as specified for withdrawal loads of nails and spikes in the NDS. Wet service factors, C_M, applicable to the F1 and F2 load directions are as specified for lateral loads of dowel-type fasteners in the NDS.

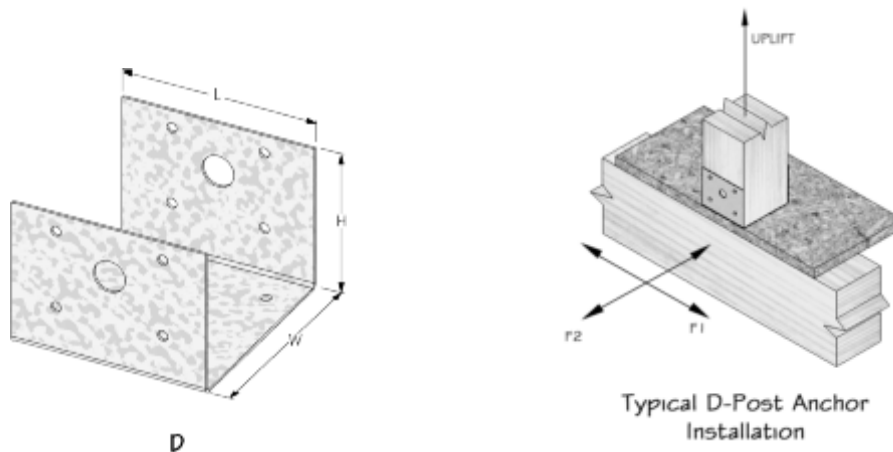

FIGURE 2—D POST ANCHOR

TABLE 6—HH HEADER HANGER ALLOWABLE LOADS^{1,2,3}

STOCK NO.	STEEL GA.	DIMENSIONS (inches)		FASTENER SCHEDULE				ALLOWABLE LOADS (lbs)					
		W	H	Header		Stud		F1		F2	F3	F4	
				Qty	Type	Qty	Type	C _D = 1.0	C _D = 1.15	C _D = 1.25	C _D = 1.6	C _D = 1.6	C _D = 1.6
HH44	16	3 ⁹ / ₁₆	3 ¹ / ₄	4	16d Common	9	16d Common	1240	1430	1500	885	685	1100
HH66	16	5 ¹ / ₂	5 ¹ / ₄	6	16d Common	12	16d Common	1655	1905	2070	1150	1325	1100

For **SI**: 1 inch = 25.4 mm, 1 lbf = 4.45 N.

¹Allowable loads have been adjusted for load duration factors, C_D, as shown, in accordance with the NDS. The allowable loads do not apply to loads of other durations, and are not permitted to be adjusted for other load durations. See Sections 4.1 and 4.2 for design and installation requirements.

²See Section 3.19.3 and Table 3 for required fastener dimensions and mechanical properties.

³Allowable loads shown are for installations in wood members complying with Section 3.19.2.

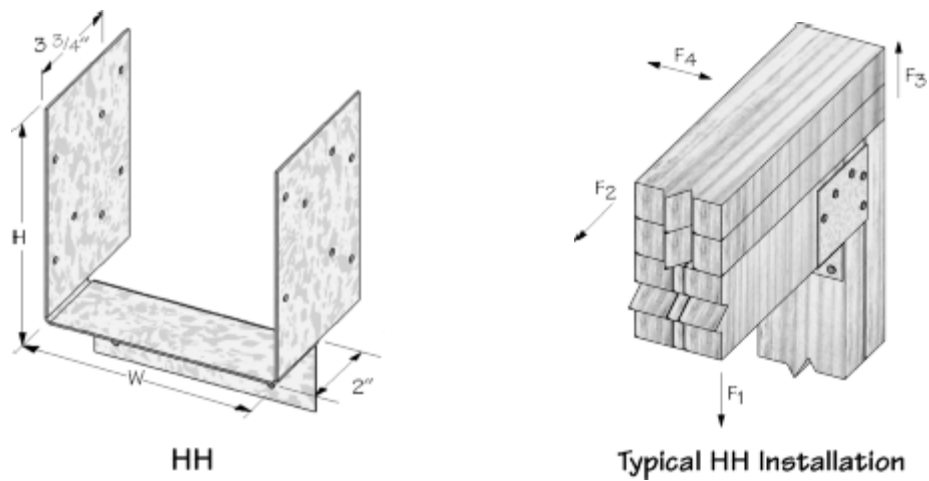

FIGURE 3—HH HEADER HANGER

TABLE 7—HL LIGHT GAGE PURLIN HANGER ALLOWABLE LOADS^{1,2,3}

STOCK NO.	STEEL GA.	DIMENSIONS (inches)				FASTENER SCHEDULE				ALLOWABLE DOWNWARD LOAD (lbs)		
						Header		Joist				
		W	H	D	TF	Qty	Type	Qty	Type	C _D = 1.0	C _D = 1.15	C _D = 1.25
HL26	18	1 ⁹ / ₁₆	5 ³ / ₈	1 ¹ / ₂	1 ⁵ / ₁₆	6	16d Common	----	----	1270	1270	1270
HL28	18	1 ⁹ / ₁₆	7 ⁵ / ₁₆	1 ³ / ₄	1 ⁵ / ₁₆	6	16d Common	----	----	1590	1590	1590
HL210	18	1 ⁹ / ₁₆	9 ⁵ / ₁₆	2	1 ⁵ / ₁₆	6	16d Common	----	----	1590	1590	1590
HL212	18	1 ⁹ / ₁₆	11 ¹ / ₄	2 ¹ / ₈	1 ⁵ / ₁₆	6	16d Common	----	----	1590	1590	1590
HL214	18	1 ⁹ / ₁₆	13 ¹ / ₈	2	2 ¹ / ₂	8	16d Common	2	10d x 1 ¹ / ₂	1590	1590	1590

For SI: 1 inch = 25.4 mm, 1 lbf = 4.45 N.

¹Allowable loads have been adjusted for load duration factors, C_D, as shown, in accordance with the NDS. The allowable loads do not apply to loads of other durations, and are not permitted to be adjusted for other load durations. See Sections 4.1 and 4.2 for design and installation requirements.

²See Section 3.19.3 and Table 3 for required fastener dimensions and mechanical properties.

³Allowable loads shown are for installations in wood members complying with Section 3.19.2. Wood members must also have a reference compression perpendicular to grain design value, F_{c⊥}, of 625 psi (4.31 MPa) or greater.

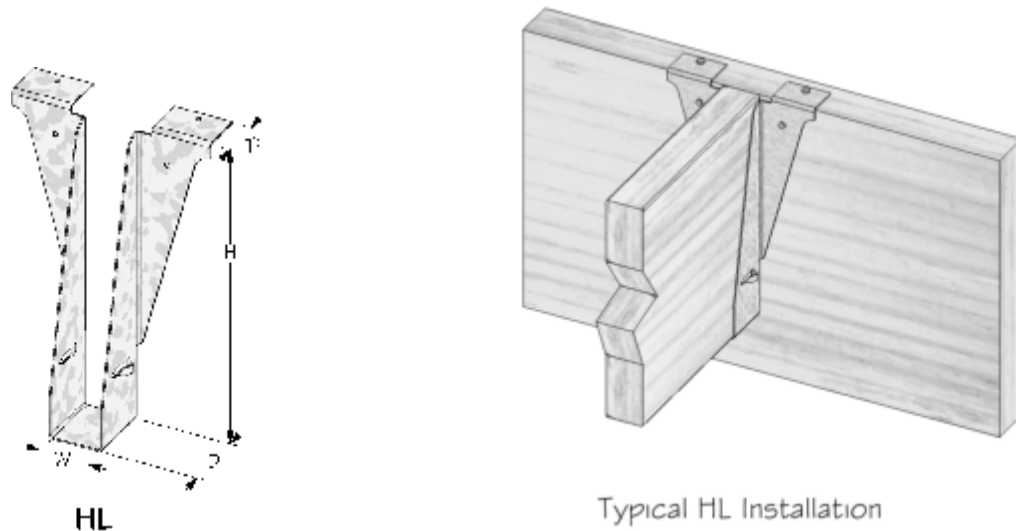

FIGURE 4—HL LIGHT GAGE PURLIN HANGER

TABLE 8—KHHB GLULAM HANGER ALLOWABLE LOADS ^{1,2,3}

STOCK NO.	STEEL GA.	DIMENSIONS (in.)				FASTENER SCHEDULE					ALLOWABLE LOADS (lbs.)		
		W	H	D	TF	Header			Joist		Download		
						Top	Face	Type	Qty	Type	C _D = 1.0	C _D = 1.15	C _D = 1.25
KHHB3	7	3 ¹ / ₄	Spec.	3	2 ¹ / ₂	4	6	NA25	6	NA25	5275	5505	5655
KHHB5	7	5 ¹ / ₄	Spec.	3	2 ¹ / ₂	4	6	NA25	6	NA25	5275	5505	5655
KHHB7	7	6 ⁷ / ₈	Spec.	3	2 ¹ / ₂	4	6	NA25	6	NA25	5275	5505	5655

For SI: 1 inch = 25.4 mm, 1 lbf = 4.45 N.

¹Allowable loads have been adjusted for load duration factors, C_D, as shown, in accordance with the NDS. The allowable loads do not apply to loads of other durations, and are not permitted to be adjusted for other load durations. See Sections 4.1 and 4.2 for design and installation requirements.

²See Section 3.19.3 and Table 3 for required fastener dimensions and mechanical properties.

³Allowable loads shown are for installations in wood members complying with Section 3.19.2. Wood members must also have a reference compression perpendicular to grain design value, F_{c⊥}, of 625 psi (4.31 MPa) or greater.

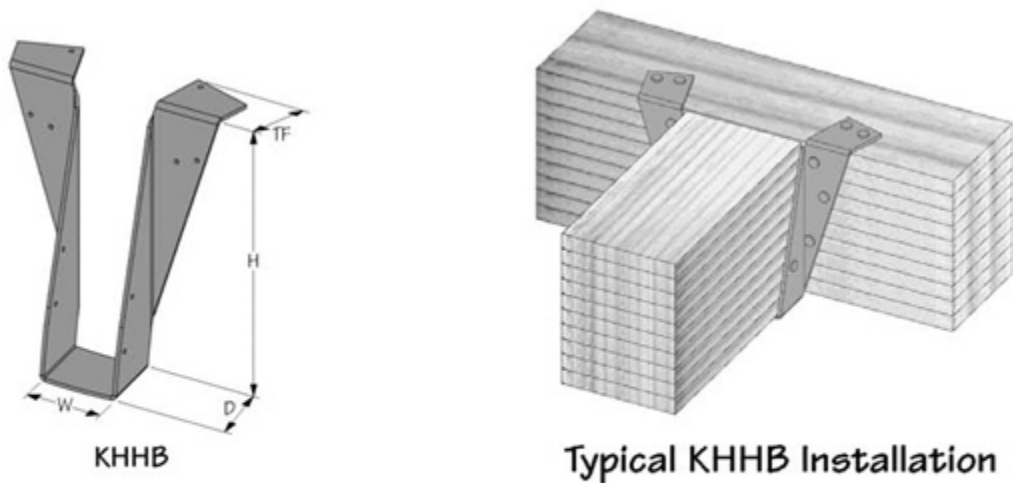

FIGURE 5—KHHB GLULAM HANGERS

TABLE 9—KEG, KMEG and KLEG GLULAM BEAM HANGER ALLOWABLE LOADS ^{1,2,3}

STOCK NO.	STEEL GAGE		DIMENSIONS (in.)					BOLT SCHEDULE			ALLOWABLE DOWNWARD LOADS (lbs.)					
	Top Flange	U-Strap	W	H ^{4,5}	D	TF	L	Hdr Qty	Joist Qty	Bolt Dia. (in)	With Top Flange			Without Top Flange		
											C _D =1.0	C _D =1.15	C _D =1.25	C _D =1.0	C _D =1.15	C _D =1.25
KLEG3	7	7	3 1/4	Spec.	6	2 1/2	12	4	2	3/4	10440	10970	11320	3540	4070	4420
KLEG5	7	7	5 1/4	Spec.	6	2 1/2	12	4	2	3/4	10440	10970	11320	3540	4070	4420
KLEG7	7	7	6 7/8	Spec.	6	2 1/2	12	4	2	3/4	10440	10970	11320	3540	4070	4420
KMEG5	7	7	5 1/4	Spec.	6	2 1/2	12	6	2	3/4	12185	12635	12635	5285	6080	6610
KMEG7	7	7	6 7/8	Spec.	6	2 1/2	12	6	2	3/4	12185	12635	12635	5285	6080	6610
KEG5	3	7	5 1/4	Spec.	6	2 1/2	12	8	2	1	16115	17495	18420	9215	10595	11520
KEG7	3	7	6 7/8	Spec.	6	2 1/2	13 1/2	8	2	1	17010	18395	19320	9245	10630	11555
KEG9	3	7	8 7/8	Spec.	6	2 1/2	15 1/2	8	2	1	18185	19580	20505	9275	10665	11595
KEG11	3	7	10 7/8	Spec.	6	2 1/2	17 1/2	8	2	1	19360	20750	21680	9295	10690	11620

For SI: 1 inch = 25.4 mm, 1 lbf = 4.45 N.

¹ Allowable loads have been adjusted for load duration factors, C_D, as shown, in accordance with the NDS. The allowable loads do not apply to loads of other durations, and are not permitted to be adjusted for other load durations. See Sections 4.1 and 4.2 for design and installation requirements.

² See Section 3.23.3 and Table 3 for required fastener dimensions and mechanical properties.

³ Allowable loads shown are for installation in wood members complying with Section 3.23.2. Wood members must also have a reference compression perpendicular to grain design value, F_{c⊥}, of 460 psi (3.17 MPa) or greater. Header members must have a minimum dimension of 5.5 inches (140 mm) in the direction parallel to the bolt axis.

⁴ The hanger height dimension must be specified by the design professional, and must be 12 inches (305 mm) or greater.

⁵ The header member height must be no less than 10 inches (254 mm) for KLEG, 13 inches (330 mm) for KMEG, and 20 inches (508 mm) for KEG hangers.

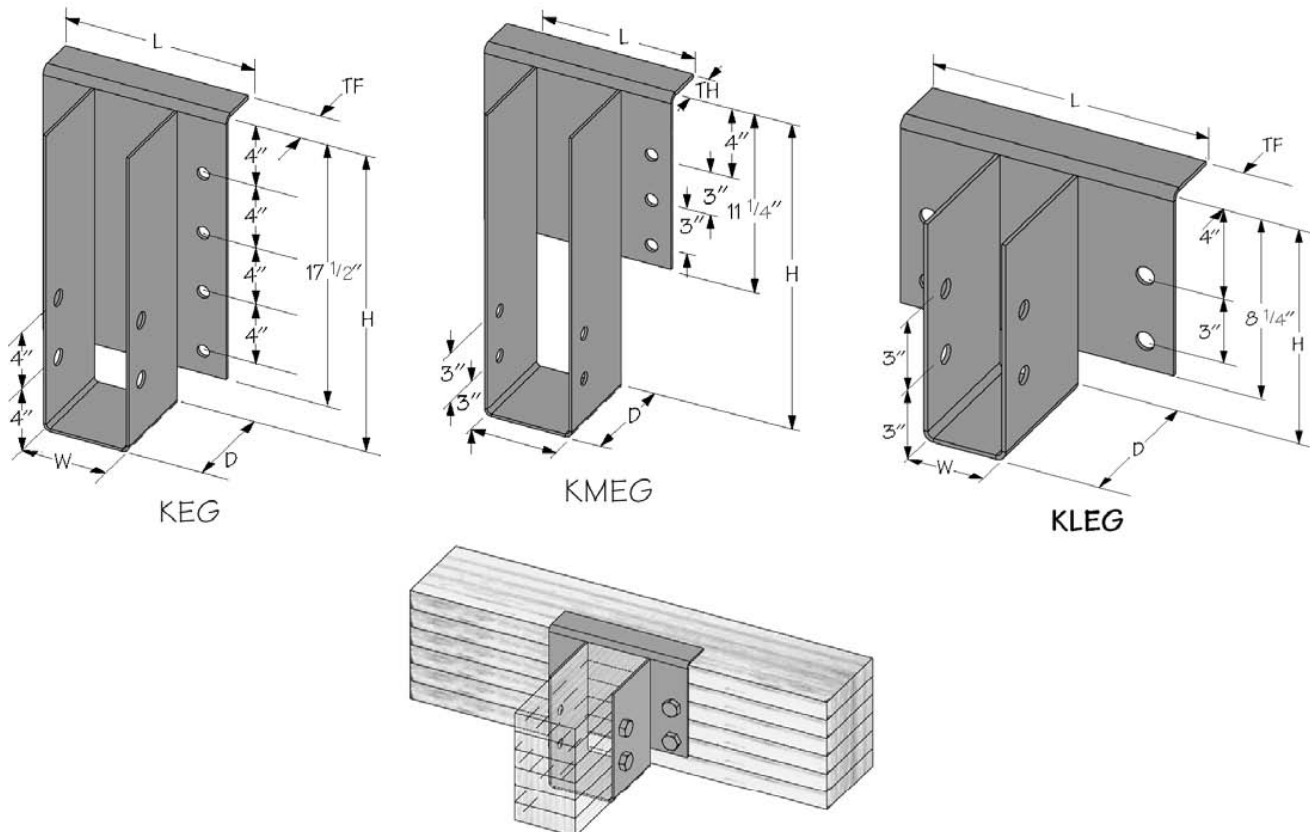

FIGURE 6—KEG, KMEG, & KLEG GLULAM BEAM HANGERS

For SI: 1 inch = 25.4 mm.

TABLE 10—KF PANEL HANGER ALLOWABLE LOADS^{1, 2, 3}

STOCK NO.	STEEL GA.	DIMENSIONS (in.)				FASTENER SCHEDULE				ALLOWABLE LOADS (lbs.)		
		W	H	D	TF	Header		Joist		Download		
						Qty	Type	Qty	Type	C _D = 1.0	C _D = 1.15	C _D = 1.25
KF44	18	3 ⁹ / ₁₆	3 ³ / ₈	1	1 ¹ / ₈	2	10d Common	1	10d x 1 ¹ / ₂	695	695	695
KF46	18	3 ⁹ / ₁₆	5 ³ / ₈	1	1 ¹ / ₈	2	10d Common	1	10d x 1 ¹ / ₂	810	810	810

¹Allowable loads have been adjusted for load duration factors, C_D, as shown, in accordance with the NDS. The allowable loads do not apply to loads of other durations, and are not permitted to be adjusted for other load durations. See Sections 4.1 and 4.2 for design and installation requirements.

²See Section 3.19.3 and Table 3 for required fastener dimensions and mechanical properties.

³Allowable loads shown are for installations in wood members complying with Section 3.19.2. Wood members must also have a reference compression perpendicular to grain design value, F_{c⊥}, of 625 psi (4.31 MPa) or greater.

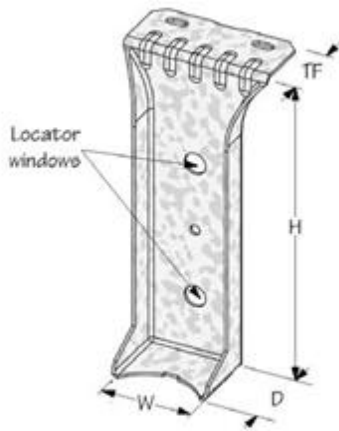

KF

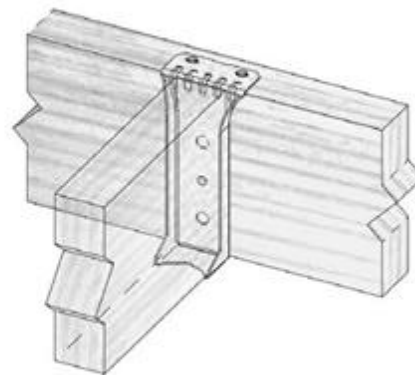

Typical KF Installation

FIGURE 7—PANEL HANGER

TABLE 11—KHST STRAP TIE ALLOWABLE LOADS 1,2,3,4

STOCK NO.	STEEL GA.	DIMENSIONS (in.)		FASTENER SCHEDULE		ALLOWABLE TENSION LOADS (lbs.)
		W	L	Total Quantity	Bolt Diameter	$C_D = 1.6$
KHST2	7	2 1/2	21 1/4	6	5/8	5250
KHST3	3	3	25 1/2	6	3/4	7920
KHST5	7	5	21 1/4	12	5/8	10635
KHST6	3	6	25 1/2	12	3/4	15935

¹Allowable loads have been adjusted for load duration factors, C_D , as shown, in accordance with the NDS. The allowable loads do not apply to loads of other durations, and are not permitted to be adjusted for other load durations. See Sections 4.1 and 4.2 for design and installation requirements.

²See Section 3.19.3 and Table 3 for required fastener dimensions and mechanical properties.

³Allowable loads shown are for installations in wood members complying with Section 3.19.2.

⁴Straps must be centered lengthwise on the joint between the two members.

⁵Applies to tension loads where the loading direction is parallel to grain in both wood members.

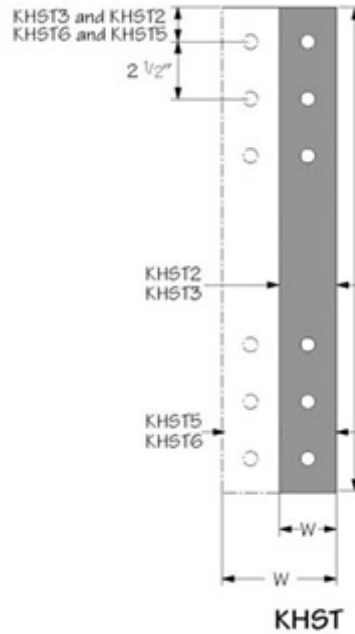

FIGURE 9—KHST STRAP TIE

TABLE 12—KGH FLOOR GIRDER HANGER ALLOWABLE LOADS ^{1,2,3,4}

STOCK NO.	GIRDER SIZE	STEEL GA.	DIMENSIONS (inches)					FASTENER SCHEDULE		ALLOWABLE LOADS (lbs.)		
			W	L	D	S	H	Qty	Type	Download		
										C _D = 1.0	C _D = 1.15	C _D = 1.25
KGH46-6	4 x 6	12	3 ⁹ / ₁₆	5	3 ¹ / ₄	6	4	4	16d Common	2050	2050	2050
KGH46-8	4 x 6	12	3 ⁹ / ₁₆	5	3 ¹ / ₄	8	4	4	16d Common	2050	2050	2050
KGH48-6	4 x 8	12	3 ⁹ / ₁₆	5	3 ¹ / ₄	6	6	4	16d Common	2050	2050	2050
KGH48-8	4 x 8	12	3 ⁹ / ₁₆	5	3 ¹ / ₄	8	6	4	16d Common	2050	2050	2050
KGH66-6	6 x 6	12	5 ¹ / ₂	6 ¹ / ₄	3 ¹ / ₄	6	4	4	16d Common	2035	2035	2035
KGH66-8	6 x 6	12	5 ¹ / ₂	6 ¹ / ₄	3 ¹ / ₄	8	4	4	16d Common	2035	2035	2035
KGH68-6	6 x 8	12	5 ¹ / ₂	6 ¹ / ₄	3 ¹ / ₄	6	6	4	16d Common	2035	2035	2035
KGH68-8	6 x 8	12	5 ¹ / ₂	6 ¹ / ₄	3 ¹ / ₄	8	6	4	16d Common	2035	2035	2035

For **SI**: 1 inch = 25.4 mm, 1 lbf = 4.45 N.

¹Allowable loads have been adjusted for load duration factors, C_D, as shown, in accordance with the NDS. The allowable loads do not apply to loads of other durations, and are not permitted to be adjusted for other load durations. See Sections 4.1 and 4.2 for design and installation requirements.

²See Section 3.19.3 and Table 3 for required fastener dimensions and mechanical properties.

³Allowable loads shown are for installations in wood members complying with Section 3.19.2.

⁴A wood sill plate must be applied over the top of the hanger as shown in the following installation figure.

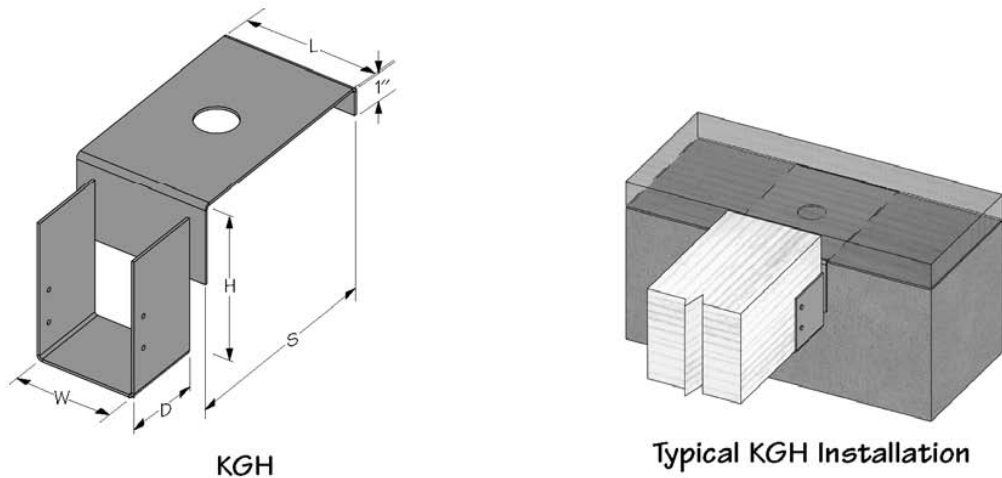

FIGURE 10—KGH FLOOR GIRDER HANGER

TABLE 13—KGLS, KGLST, KHGLS and KHGLST GLULAM SADDLE HANGER ALLOWABLE LOADS

STOCK NO.	JOIST SIZE & TYPE		STEEL GAGE		HANGER DIMENSIONS (in.)					NAIL SCHEDULE PER SIDE				BOLT SCHEDULE PER SIDE			
			Top Flange	Stirrup	W	H ^{4,5}	D	L	TF	Header		Joist		Header		Joist	
										Qty	Type	Qty	Type	Qty	Type	Qty	Type
KGLS35	3 ¹ / ₈	Glulam	3	7	3 ¹ / ₄	spec.	5	6	5 ¹ / ₄	6	NA25	6	NA25	-	-	-	-
KGLST35	3 ¹ / ₈	Glulam	3	7	3 ¹ / ₄	spec.	6 ¹ / ₂	10	5 ¹ / ₄	6	NA25	6	NA25	2	3 ³ / ₄	3	3 ³ / ₄
KGLS37	3 ¹ / ₈	Glulam	3	7	3 ¹ / ₄	spec.	5	6	6 ⁷ / ₈	6	NA25	6	NA25	-	-	-	-
KGLST37	3 ¹ / ₈	Glulam	3	7	3 ¹ / ₄	spec.	6 ¹ / ₂	10	6 ⁷ / ₈	6	NA25	6	NA25	2	3 ³ / ₄	3	3 ³ / ₄
KGLS39	3 ¹ / ₈	Glulam	3	7	3 ¹ / ₄	spec.	5	6	8 ⁷ / ₈	6	NA25	6	NA25	-	-	-	-
KGLST39	3 ¹ / ₈	Glulam	3	7	3 ¹ / ₄	spec.	6 ¹ / ₂	10	8 ⁷ / ₈	6	NA25	6	NA25	2	3 ³ / ₄	3	3 ³ / ₄
KGLS55	5 ¹ / ₈	Glulam	3	7	5 ¹ / ₄	spec.	5	9	5 ¹ / ₄	6	NA25	6	NA25	-	-	-	-
KGLST55	5 ¹ / ₈	Glulam	3	7	5 ¹ / ₄	spec.	6 ¹ / ₂	12	5 ¹ / ₄	6	NA25	6	NA25	2	3 ³ / ₄	3	3 ³ / ₄
KGLS57	5 ¹ / ₈	Glulam	3	7	5 ¹ / ₄	spec.	5	9	6 ⁷ / ₈	6	NA25	6	NA25	-	-	-	-
KGLST57	5 ¹ / ₈	Glulam	3	7	5 ¹ / ₄	spec.	6 ¹ / ₂	12	6 ⁷ / ₈	6	NA25	6	NA25	2	3 ³ / ₄	3	3 ³ / ₄
KGLS77	6 ³ / ₄	Glulam	3	7	6 ¹ / ₈	spec.	5	12	6 ⁷ / ₈	6	NA25	6	NA25	-	-	-	-
KGLST77	6 ³ / ₄	Glulam	3	7	6 ¹ / ₈	spec.	6 ¹ / ₂	12	6 ⁷ / ₈	6	NA25	6	NA25	2	3 ³ / ₄	3	3 ³ / ₄
KGLS79	6 ³ / ₄	Glulam	3	7	6 ¹ / ₈	spec.	5	12	8 ⁷ / ₈	6	NA25	6	NA25	-	-	-	-
KGLST79	6 ³ / ₄	Glulam	3	7	6 ¹ / ₈	spec.	6 ¹ / ₂	12	8 ⁷ / ₈	6	NA25	6	NA25	2	3 ³ / ₄	3	3 ³ / ₄
KHGLS5	5 ¹ / ₈	Glulam	3	7	5 ¹ / ₄	spec.	6 ¹ / ₂	12	spec.	14	NA25	8	NA25	-	-	-	-
KHGLST5	5 ¹ / ₈	Glulam	3	7	5 ¹ / ₄	spec.	6	12	spec.	14	NA25	8	NA25	2	3 ³ / ₄	3	3 ³ / ₄
KHGLS7	6 ³ / ₄	Glulam	3	7	6 ¹ / ₈	spec.	6	12	spec.	14	NA25	8	NA25	-	-	-	-
KHGLST7	6 ³ / ₄	Glulam	3	7	6 ¹ / ₈	spec.	6 ¹ / ₂	14	spec.	14	NA25	8	NA25	2	3 ³ / ₄	3	3 ³ / ₄
KHGLS9	8 ³ / ₄	Glulam	3	7	8 ¹ / ₈	spec.	6	12	spec.	14	NA25	8	NA25	-	-	-	-
KHGLST9	8 ³ / ₄	Glulam	3	7	8 ¹ / ₈	spec.	6 ¹ / ₂	16	spec.	14	NA25	8	NA25	2	3 ³ / ₄	3	3 ³ / ₄

STOCK NO.	JOIST SIZE & TYPE		ALLOWABLE LOADS (lbs.)			
			Download			Tension
			C _D = 1.0	C _D = 1.15	C _D = 1.25	C _D = 1.6
KGLS35	3 ¹ / ₈	Glulam	8710	8940	9095	—
KGLST35	3 ¹ / ₈	Glulam	10870	11095	11250	15120
KGLS37	3 ¹ / ₈	Glulam	8710	8940	9095	—
KGLST37	3 ¹ / ₈	Glulam	10870	11095	11250	15120
KGLS39	3 ¹ / ₈	Glulam	8710	8940	9095	—
KGLST39	3 ¹ / ₈	Glulam	10870	11095	11250	15120
KGLS55	5 ¹ / ₈	Glulam	12405	12670	12850	—
KGLST55	5 ¹ / ₈	Glulam	15940	16210	16390	15120
KGLS57	5 ¹ / ₈	Glulam	13310	13540	13695	—
KGLST57	5 ¹ / ₈	Glulam	16850	17075	17230	15120
KGLS77	6 ³ / ₄	Glulam	17050	17280	17430	—
KGLST77	6 ³ / ₄	Glulam	20425	20695	20875	15120
KGLS79	6 ³ / ₄	Glulam	17050	17280	17430	—
KGLST79	6 ³ / ₄	Glulam	21705	21935	22090	15120
KHGLS5	5 ¹ / ₈	Glulam	17355	17660	17865	—
KHGLST5	5 ¹ / ₈	Glulam	16175	16480	16685	15120
KHGLS7	6 ³ / ₄	Glulam	17985	18615	19035	—
KHGLST7	6 ³ / ₄	Glulam	20285	20915	21335	15120
KHGLS9	8 ³ / ₄	Glulam	17985	18615	19035	—
KHGLST9	8 ³ / ₄	Glulam	22585	23215	23635	15120

For SI: 1 inch = 25.4 mm, 1 lbf = 4.45 N.

¹Allowable loads have been adjusted for load duration factors, C_D, as shown, in accordance with the NDS. The allowable loads do not apply to loads of other durations, and are not permitted to be adjusted for other load durations. See Sections 4.1 and 4.2 for design and installation requirements.

²See Section 3.19.3 and Table 3 for required fastener dimensions and mechanical properties.

³Allowable loads shown are for installations in wood members complying with Section 3.19.2. Wood members must also have a reference compression perpendicular to grain design value, F_{c2}, of 460 psi (3.17 MPa) or greater.

⁴The hanger height dimension must be specified by the design professional, and must be 12 inches (305 mm) or greater.

⁵The header member height must be no less than 8.5 inches (216 mm) for KGLS, 9 inches (229 mm) for KGLST, 10.5 inches (267 mm) for KHGLS, and 12 inches (305 mm) for KHGLST hangers.

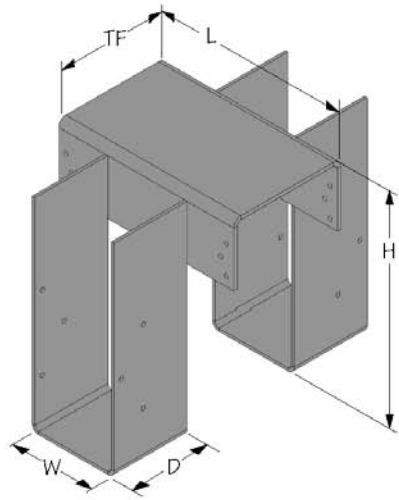

KGLS
(KHGLS similar)

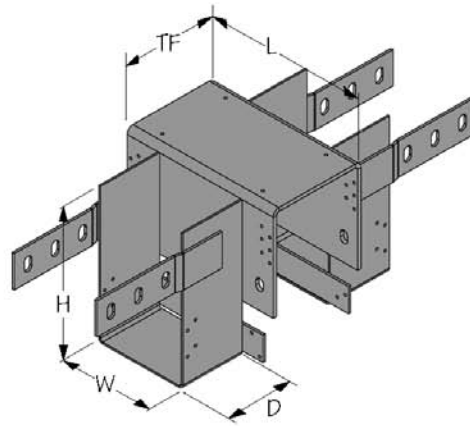

KHGLST
(KGLST similar)

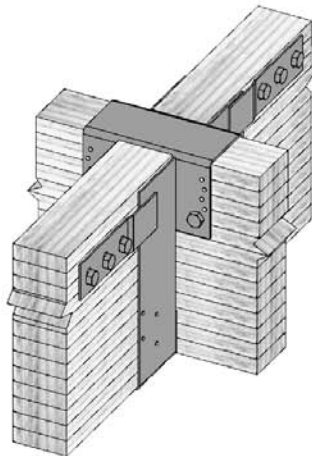

Typical KHGLST
installation
(KGLST similar)

FIGURE 11—KGLS, KGLST, KHGLS & KHGLST GLULAM SADDLE HANGERS

TABLE 14—KGLT and KHGLT GLULAM HANGER ALLOWABLE LOADS ^{2,3,4}

STOCK NO.	STEEL GAGE		DIMENSIONS (in.)				FASTENER SCHEDULE			
	Top Flange	U-Strap	W	H ⁴	D	L	Header Qty		Joist Qty	Nail Type
							Top	Face		
KGLT3	3	7	3 ¹ / ₄	Spec.	5	10	4	6	8	NA25
KGLT4	3	7	3 ⁵ / ₈	Spec.	5	10	4	6	8	NA25
KGLT5	3	7	5 ¹ / ₄	Spec.	5	10	4	6	8	NA25
KGLT8	3	7	5 ⁵ / ₈	Spec.	5	10	4	6	8	NA25
KGLT7	3	7	6 ⁷ / ₈	Spec.	5	10	4	6	8	NA25
KGLT9	3	7	8 ⁷ / ₈	Spec.	5	10	4	6	8	NA25
KHGLT3	3	7	3 ¹ / ₄	Spec.	6	12	6	12	6	NA25
KHGLT4	3	7	3 ⁵ / ₈	Spec.	6	12	6	12	6	NA25
KHGLT5	3	7	5 ¹ / ₄	Spec.	6	12	6	12	6	NA25
KHGLT6	3	7	5 ⁵ / ₈	Spec.	6	12	6	12	6	NA25
KHGLT7	3	7	6 ⁷ / ₈	Spec.	6	12	6	12	6	NA25
KHGLT9	3	7	8 ⁷ / ₈	Spec.	6	14	6	12	6	NA25
KHGLT11	3	7	10 ⁷ / ₈	Spec.	6	16	6	12	6	NA25

STOCK NO.	ALLOWABLE LOADS (lbs.)					
	Download					
	F _{C-perp} = 460 psi			F _{C-perp} = 625 psi		
	C _D = 1.0	C _D = 1.15	C _D = 1.25	C _D = 1.0	C _D = 1.15	C _D = 1.25
KGLT3	7545	7815	7995	—	—	—
KGLT4	7545	7815	7995	—	—	—
KGLT5	7545	7815	7995	—	—	—
KGLT6	7545	7815	7995	—	—	—
KGLT7	7545	7815	7995	—	—	—
KGLT9	7545	7815	7995	—	—	—
KHGLT3	10150	10380	10530	12965	13400	13400
KHGLT4	10490	11025	11385	12965	13400	13400
KHGLT5	10490	11025	11385	12965	13400	13400
KHGLT6	10490	11025	11385	12965	13400	13400
KHGLT7	10490	11025	11385	12965	13400	13400
KHGLT9	11840	12175	12535	13400	13400	13400
KHGLT11	12790	13325	13400	13400	13400	13400

For SI: 1 inch = 25.4 mm, 1 lbf = 4.45 N, 1 psi = 6.89 kPa.

¹Allowable loads have been adjusted for load duration factors, C_D, as shown, in accordance with the NDS. The allowable loads do not apply to loads of other durations, and are not permitted to be adjusted for other load durations. See Sections 4.1 and 4.2 for design and installation requirements.

²See Section 3.19.3 and Table 3 for required fastener dimensions and mechanical properties.

³Allowable loads shown are for installations in wood members complying with Section 3.19.2. Wood members must also have a reference compression perpendicular to grain design value, F_{c2,⊥}, of 460 psi (3.17 MPa) or 625 psi (4.31 MPa), as indicated in the table.

⁴The hanger height dimension must be specified by the design professional, and must be 7.5 inches (191 mm) or greater.

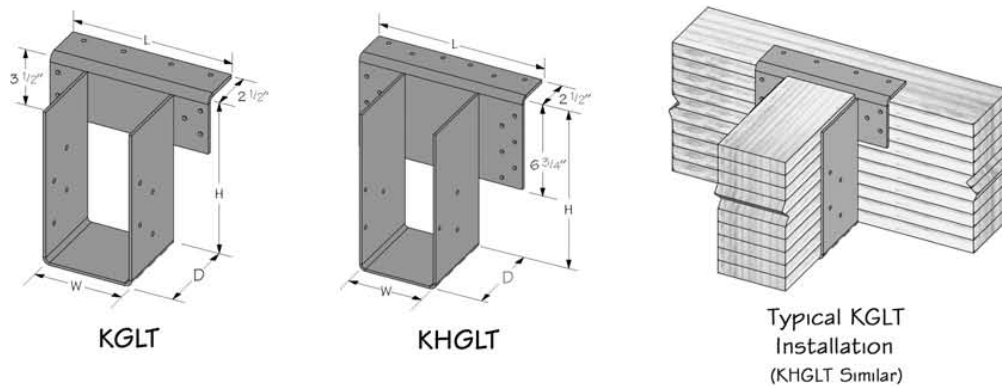

FIGURE 12—KGLT & KHGLT GLULAM HANGERS

For SI: 1 inch = 25.4 mm.

TABLE 15—KHC HINGE CONNECTOR AND KHCST SEISMIC STRAP ALLOWABLE LOADS^{1,2,3,4}

STOCK NO.	WOOD MEMBERS		STEEL THICKNESS		DIMENSIONS (inches)				FASTENER SCHEDULE ⁵		MINIMUM HEIGHT (in) ^{5,6}		ALLOWABLE LOADS (lbs)	
	Beam Type	Beam Size (in)	Sides Gage	T (in)	W	PD	PT	H	Qty	Bolt Dia.	2-Bolt	3-Bolt	F _{C-perp} = 410 psi	F _{C-perp} = 560 psi
KHC55	Glulam	5 ¹ / ₈	7	3 ³ / ₄	5 ¹ / ₄	5	3 ³ / ₄	Spec.	Spec.	3 ³ / ₄	17 ¹ / ₂	14	10505	14350
KHC56	Glulam	5 ¹ / ₈	7	3 ³ / ₄	5 ¹ / ₄	6	3 ³ / ₄	Spec.	Spec.	3 ³ / ₄	22 ³ / ₄	17 ¹ / ₂	12610	17220
KHC57	Glulam	5 ¹ / ₈	7	3 ³ / ₄	5 ¹ / ₄	7	3 ³ / ₄	Spec.	Spec.	3 ³ / ₄	28 ³ / ₄	21 ³ / ₄	14710	20090
KHC59	Glulam	5 ¹ / ₈	7	3 ³ / ₄	5 ¹ / ₄	9	3 ³ / ₄	Spec.	Spec.	3 ³ / ₄	43 ¹ / ₂	32	18910	25830
KHC75	Glulam	6 ³ / ₄	7	1	6 ¹ / ₈	5	1	Spec.	Spec.	3 ³ / ₄	20 ³ / ₄	16	13840	18900
KHC76	Glulam	6 ³ / ₄	7	1	6 ¹ / ₈	6	1	Spec.	Spec.	3 ³ / ₄	27 ¹ / ₂	20 ³ / ₄	16605	22680
KHC77	Glulam	6 ³ / ₄	7	1	6 ¹ / ₈	7	1	Spec.	Spec.	3 ³ / ₄	35 ¹ / ₂	26 ¹ / ₄	19375	26460
KHC79	Glulam	6 ³ / ₄	7	1	6 ¹ / ₈	9	1	Spec.	Spec.	3 ³ / ₄	55	40	24910	34020
KHC95	Glulam	8 ³ / ₄	7	1 ¹ / ₄	8 ¹ / ₈	5	1 ¹ / ₄	Spec.	Spec.	3 ³ / ₄	24 ³ / ₄	18 ³ / ₄	17940	24500
KHC96	Glulam	8 ³ / ₄	7	1 ¹ / ₄	8 ¹ / ₈	6	1 ¹ / ₄	Spec.	Spec.	3 ³ / ₄	33 ¹ / ₂	24 ³ / ₄	21525	29400
KHC97	Glulam	8 ³ / ₄	7	1 ¹ / ₄	8 ¹ / ₈	7	1 ¹ / ₄	Spec.	Spec.	3 ³ / ₄	43 ³ / ₄	32	25115	34300
KHC99	Glulam	8 ³ / ₄	7	1 ¹ / ₄	8 ¹ / ₈	9	1 ¹ / ₄	Spec.	Spec.	3 ³ / ₄	69 ¹ / ₄	49 ³ / ₄	32290	44100
KHC115	Glulam	10 ³ / ₄	3	1 ¹ / ₂	10 ⁷ / ₈	5	1 ¹ / ₂	Spec.	Spec.	3 ³ / ₄	27 ¹ / ₄	20 ¹ / ₄	22040	30100
KHC116	Glulam	10 ³ / ₄	3	1 ¹ / ₂	10 ⁷ / ₈	6	1 ¹ / ₂	Spec.	Spec.	3 ³ / ₄	37 ¹ / ₄	27	26445	36120
KHC117	Glulam	10 ³ / ₄	3	1 ¹ / ₂	10 ⁷ / ₈	7	1 ¹ / ₂	Spec.	Spec.	3 ³ / ₄	49 ¹ / ₄	35 ¹ / ₄	30855	42140
KHC119	Glulam	10 ³ / ₄	3	1 ¹ / ₂	10 ⁷ / ₈	9	1 ¹ / ₂	Spec.	Spec.	3 ³ / ₄	78 ¹ / ₄	55 ¹ / ₄	39670	54180

STOCK NO	DIMENSIONS (inches)			FASTENER SCHEDULE		ALLOWABLE F1 LOAD (lbs) ^{7,8}
	Steel Gage	W	L	Qty	Bolt Dia.	
KHCST2	7	3 ¹ / ₂	25 ⁵ / ₈	4	3 ³ / ₄	9950
KHCST3	7	3 ¹ / ₂	31 ⁵ / ₈	6	3 ³ / ₄	14500
KHCST4	3	3 ¹ / ₂	37 ⁵ / ₈	8	3 ³ / ₄	20145
KHCSTR2	7	3 ¹ / ₂	25 ⁵ / ₈	4	3 ³ / ₄	9950
KHCSTR3	7	3 ¹ / ₂	31 ⁵ / ₈	6	3 ³ / ₄	14500
KHCSTR4	3	3 ¹ / ₂	37 ⁵ / ₈	8	3 ³ / ₄	20145

For SI: 1 inch = 25.4 mm, 1 lbf = 4.45 N, 1 psi = 6.89 kPa.

¹ Allowable downward loads correspond to a load duration, C_D, of 1.0. No further increases for duration of load are permitted. Allowable F1 loads have been adjusted for a load duration factor of 1.6, corresponding to a ten-minute load duration (i.e., wind or earthquake loading) in accordance with the NDS. The allowable F1 loads do not apply to loads of other durations. See Sections 4.1 and 4.2 for design and installation requirements

² See Section 3.19.3 and Table 3 for required fastener dimensions and mechanical properties.

³ Allowable loads shown are for installations in wood members complying with Section 3.19.2. Wood members must also have a reference compression perpendicular to grain design value, F_{c2}, of 410 psi (2.83 MPa) or 560 psi (3.86 MPa), as indicated in the table above.

⁴ KHCST and KHCSTR seismic straps must be used in conjunction with the KHC device whenever the design loads include a horizontal tension load in the F1 direction.

⁵ Specify 2 or 3 bolt rotation tab. The minimum height depends on the rotation tab specified.

⁶ Minimum heights correspond to loads shown. Allowable loads must be reduced in direct proportion for lesser heights.

⁷ Allowable F1 (tension) loads for the KHCST and KHCSTR apply for installations on beams with a minimum width of 5.125 inches (130 mm).

⁸ KHCST and KHCSTR seismic straps must be used in pairs, with one strap on each side of the beam, such that the bolts are loaded in double shear. Allowable F1 loads apply to one pair of seismic straps

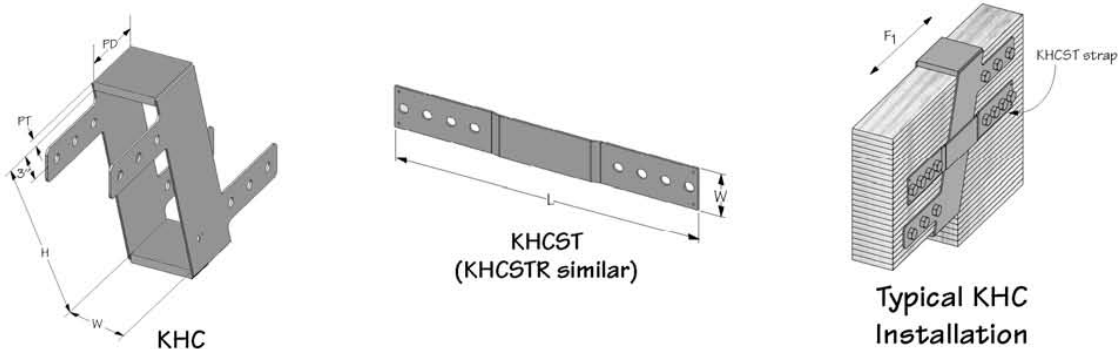

FIGURE 13—KHC HINGE CONNECTOR & KHCST SEISMIC STRAP

For SI: 1 inch = 25.4 mm.

TABLE 16—KSA & KHSA CONNECTOR STRAPS

STOCK NO.	STEEL GAGE	DIMENSIONS (inches)					FASTENER SCHEDULE				ALLOWABLE TENSION LOADS (lbs)	
		W	L	O	D1	D2	Nails		Bolts		Nails C _D = 1.6	Bolts C _D = 1.6
							Qty	Type	Qty	Dia		
KSA36	12	2 ¹ / ₁₆	37 ⁷ / ₈	9	6 ¹¹ / ₁₆	4 ¹ / ₂	22	16d Common	4	1 ¹ / ₂	2620	2015
KHSA1	3	3	30	9	10	-	-	-	2	3 ³ / ₄	-	2435
KHSA2	3	3	38 ¹ / ₂	9	10	4 ¹ / ₂	-	-	4	3 ³ / ₄	-	4810
KHSA3	3	3	47	9	10	4 ¹ / ₂	-	-	6	3 ³ / ₄	-	7005
KHSA4	3	3	56	9	10	4 ¹ / ₂	-	-	8	3 ³ / ₄	-	8920
KHSA5	3	3 ¹ / ₂	64 ¹ / ₂	9	10	4 ¹ / ₂	-	-	10	3 ³ / ₄	-	10785

¹Allowable downward loads correspond to a load duration, C_D, of 1.6, corresponding to a ten-minute load duration (i.e., wind or earthquake loading) in accordance with the NDS. The allowable F1 loads do not apply to loads of other durations. See Sections 4.1 and 4.2 for design and installation requirements

²See Section 3.19.3 and Table 3 for required fastener dimensions and mechanical properties.

³Allowable loads shown are for installations in wood members complying with Section 3.19.2. Wood members must have minimum dimensions of 3.5 inches (89 mm) in the direction parallel to the bolt axis.

⁴Eccentric loading conditions must be considered in connection design

⁵Allowable nail loads and bolt loads are not permitted to be added together.

⁶Bolt loads are for single shear conditions

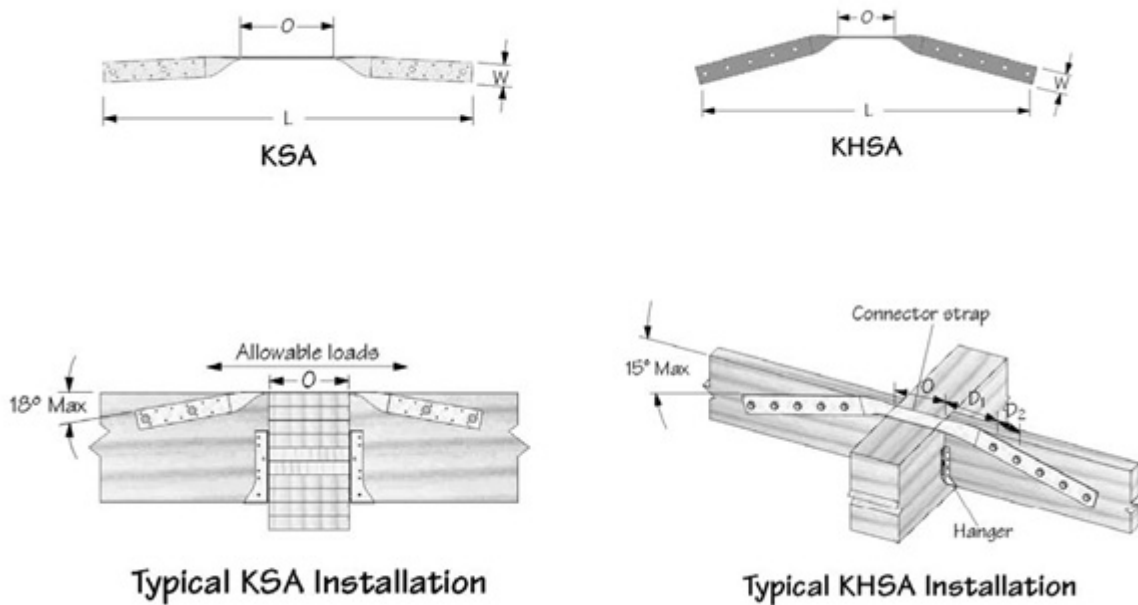

FIGURE 14—KSA & KHSA CONNECTOR STRAPS

TABLE 17—KVB and KVBI KNEE BRACE ALLOWABLE LOADS ^{1,2,3,4}

STOCK NO.	STEEL GAGE	DIMENSIONS (in)			FASTENER SCHEDULE				ALLOWABLE TENSIONS LOADS (lbs)			
					Beam		Joist					
		Beam Depth	W	L	Qty	Type	Qty	Type	C _D = 1.0	C _D = 1.15	C _D = 1.25	C _D = 1.6
KVB5	12	10" - 15"	2 ¹ / ₁₆	60	4	NA25	12	NA25	1310	1505	1635	1800
KVB7	12	15" - 22 ¹ / ₂ "	2 ¹ / ₁₆	84	4	NA25	12	NA25	1310	1505	1635	1800
KVB8	12	22 ¹ / ₂ " - 28 ¹ / ₂ "	2 ¹ / ₁₆	96	4	NA25	12	NA25	1310	1505	1635	1800
KVB10	12	28 ¹ / ₂ " - 36"	2 ¹ / ₁₆	120	4	NA25	12	NA25	1310	1505	1635	1800
KVB12	12	36" - 42"	2 ¹ / ₁₆	144	4	NA25	12	NA25	1310	1505	1635	1800
KVBI5	12	10" - 15"	2 ¹ / ₁₆	60	4	10d Common	12	10d Common	760	875	955	1220
KVBI7	12	15" - 22 ¹ / ₂ "	2 ¹ / ₁₆	84	6	10d Common	12	10d Common	760	875	955	1220
KVBI8	12	22 ¹ / ₂ " - 28 ¹ / ₂ "	2 ¹ / ₁₆	96	6	10d Common	12	10d Common	760	875	955	1220
KVBI10	12	28 ¹ / ₂ " - 36"	2 ¹ / ₁₆	120	6	10d Common	12	10d Common	760	875	955	1220
KVBI12	12	36" - 42"	2 ¹ / ₁₆	144	6	10d Common	12	10d Common	760	875	955	1220

¹Allowable downward loads correspond to a load duration, C_D, as shown in accordance with the NDS. The allowable loads do not apply to loads of other durations, and are not permitted to be adjusted for other load durations. See Sections 4.1 and 4.2 for design and installation requirements

²See Section 3.19.3 and Table 3 for required fastener dimensions and mechanical properties.

³Allowable loads shown are for installations in wood members complying with Section 3.19.2.

⁴Allowable loads apply to tensile loads along the length of the strap

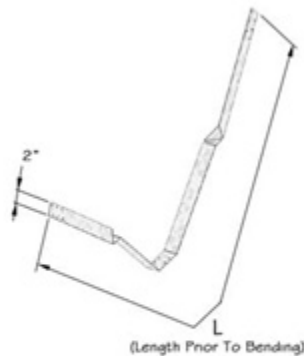

KVB
(KVBI SIMILAR)

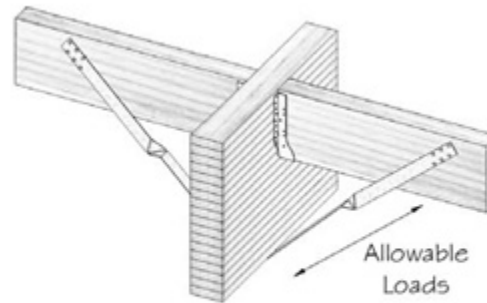

Typical KVB Installation
(KVBI Similar)

FIGURE 15—KVB KNEE BRACE

TABLE 18—PHG PANEL HANGER ALLOWABLE LOADS ^{1,2,3}

STOCK NO.	STEEL GAGE	DIMENSIONS (inches)				FASTENER SCHEDULE				ALLOWABLE LOADS (lbs)		
						Header		Joist		Download		
		W	H	D	TF	Qty	Type	Qty	Type	C _D = 1.0	C _D = 1.15	C _D = 1.25
PHG24	18	1 ⁹ / ₁₆	3 ¹ / ₂	1 ³ / ₁₆	1 ¹ / ₁₆	2	8d Common	--	--	580	580	580
PHG26	18	1 ⁹ / ₁₆	5 ³ / ₈	1	1 ¹ / ₁₆	2	10d Common	--	--	650	650	650
PHG34	18	2 ⁹ / ₁₆	3 ¹ / ₂	1	1 ¹ / ₈	2	10d Common	--	--	650	650	650
PHG36	18	2 ⁹ / ₁₆	5 ³ / ₈	1	1 ¹ / ₈	2	10d Common	--	--	650	650	650
PHG24-2	18	3 ¹ / ₈	3 ¹ / ₂	1	1 ¹ / ₈	2	10d Common	--	--	650	650	650
PHG26-2	18	3 ¹ / ₈	5 ³ / ₈	1	1 ¹ / ₈	2	10d Common	--	--	650	650	650

¹Allowable downward loads correspond to a load duration, C_D, as shown in accordance with the NDS. The allowable loads do not apply to loads of other durations, and are not permitted to be adjusted for other load durations. See Sections 4.1 and 4.2 for design and installation requirements

²See Section 3.19.3 and Table 3 for required fastener dimensions and mechanical properties.

³Allowable loads shown are for installations in wood members complying with Section 3.19.2. Wood members must also have a reference compression perpendicular to grain design value, F_{c2}, of 625 psi (4.31 MPa) or greater.

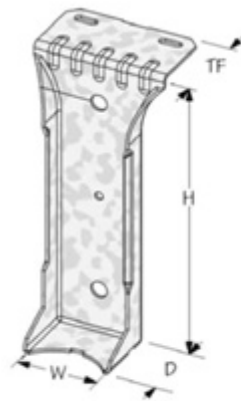

PHG

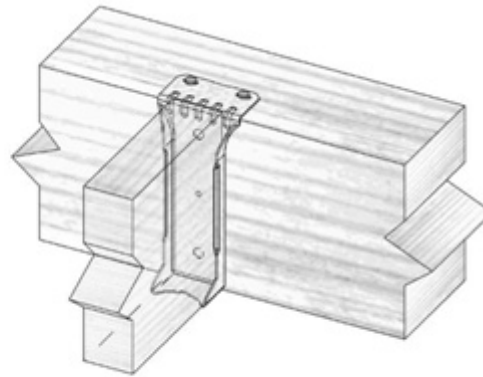

Typical PHG Installation

FIGURE 16—PHG PANEL HANGER

TABLE 19—SCA STAIR ANGLE ALLOWABLE LOADS ^{1, 2, 3, 4}

STOCK NO.	STEEL GAGE	DIMENSIONS (in)			FASTENER SCHEDULE		ALLOWABLE DOWNLOAD (lbs) C _D = 1.0
		L	W	D	Qty	Type	
SCA9-TZ	12	9	1 ³ / ₈	1 ³ / ₈	6	1/4" x 1 1/2" Lag Screw	335
SCA10-TZ	12	10	1 ³ / ₈	1 ³ / ₈	8	1/4" x 1 1/2" Lag Screw	450

¹Allowable downward loads correspond to a load duration, C_D, of 1.0. No further increases for duration of load are permitted. See Sections 4.1 and 4.2 for design and installation requirements

²See Section 3.19.3 and Table 3 for required fastener dimensions and mechanical properties.

³Allowable loads shown are for installations in wood members complying with Section 3.19.2.

⁴Allowable loads are for downward loads on stair treads with a rise of 7 inches (178 mm) and a run of 11 inches (279 mm), for a stringer angle of 32.5 degrees from horizontal.

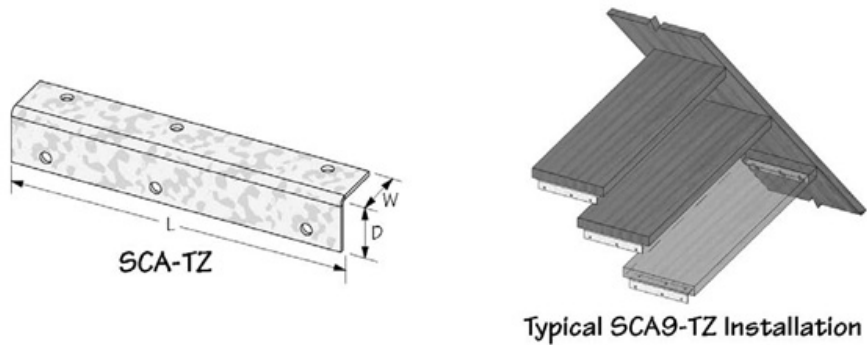

FIGURE 17—SCA STAIR ANGLE

TABLE 20—SUH JOIST HANGER ALLOWABLE LOADS^{1, 2, 3}

STOCK NO.	STEEL GAGE	DIMENSIONS (in)				FASTENER SCHEDULE				ALLOWABLE LOADS (lbs)						
										Download						
		W	H	D	A	Header		Joist		16d Common Nails Into Header			10d Common Nails Into Header			
Qty	Type					Qty	Type	C _D = 1.0	C _D = 1.15	C _D = 1.25	C _D = 1.0	C _D = 1.15	C _D = 1.25	C _D = 1.6		
SUH24	16	1 ⁹ / ₁₆	3 ¹ / ₄	2	1 ³ / ₁₆	4	10dC or 16dC	2	10dx1 ¹ / ₂	550	635	690	465	535	580	360
SUH26	16	1 ⁹ / ₁₆	5 ¹ / ₈	2	1 ³ / ₁₆	6	10dC or 16dC	4	10dx1 ¹ / ₂	830	950	1035	695	800	870	725
SUH28	16	1 ⁹ / ₁₆	6 ⁵ / ₈	2	1 ³ / ₁₆	8	10dC or 16dC	6	10dx1 ¹ / ₂	1105	1270	1380	930	1065	1160	800
SUH210	16	1 ⁹ / ₁₆	8	2	1 ³ / ₁₆	10	10dC or 16dC	6	10dx1 ¹ / ₂	1380	1585	1725	1160	1335	1450	1085
SUH214	16	1 ⁹ / ₁₆	10	2	1 ¹ / ₈	12	10dC or 16dC	8	10dx1 ¹ / ₂	1655	1905	2070	1390	1600	1740	1330
SUH24R	16	2	3 ¹ / ₁₆	2	1 ¹ / ₈	4	10dC or 16dC	2	10dx1 ¹ / ₂	550	635	690	465	535	580	360
SUH26R	16	2	4 ¹⁵ / ₁₆	2	1 ³ / ₁₆	6	10dC or 16dC	4	10dx1 ¹ / ₂	830	950	1035	695	800	870	725
SUH28R	16	2	6 ⁷ / ₁₆	2	1 ¹ / ₈	8	10dC or 16dC	6	10dx1 ¹ / ₂	1105	1270	1380	930	1065	1160	800
SUH210R	16	2	7 ¹³ / ₁₆	2	1 ¹ / ₈	10	10dC or 16dC	6	10dx1 ¹ / ₂	1380	1585	1725	1160	1335	1450	1085
SUH214R	16	2	9 ⁹ / ₁₆	2	1 ¹ / ₈	12	10dC or 16dC	6	10dx1 ¹ / ₂	1655	1905	2070	1390	1600	1740	1085
SUH34	16	2 ⁹ / ₁₆	3 ³ / ₈	2	1 ¹ / ₈	6	10dC or 16dC	2	10dx1 ¹ / ₂	830	850	850	695	800	850	360
SUH36	16	2 ⁹ / ₁₆	5 ⁵ / ₁₆	2	1 ¹ / ₈	8	10dC or 16dC	4	10dx1 ¹ / ₂	1105	1270	1380	930	1065	1160	725
SUH310	16	2 ⁹ / ₁₆	8 ⁷ / ₈	2	1 ¹ / ₈	14	10dC or 16dC	6	10dx1 ¹ / ₂	1930	2220	2415	1625	1870	2030	1085
SUH314	16	2 ⁹ / ₁₆	10 ⁹ / ₁₆	2	1 ¹ / ₈	16	10dC or 16dC	6	10dx1 ¹ / ₂	2210	2505	2505	1855	2135	2320	1085
SUH24-2	16	3 ¹ / ₈	3 ¹ / ₈	2	1 ¹ / ₈	6	10dC or 16dC	2	10d Common	830	950	1035	695	800	870	370
SUH26-2	16	3 ¹ / ₈	5 ¹ / ₁₆	2	1 ¹ / ₈	8	10dC or 16dC	4	10d Common	1105	1270	1380	930	1065	1160	740
SUH28-2	16	3 ¹ / ₈	6 ¹ / ₄	2	1 ¹ / ₈	10	10dC or 16dC	4	10d Common	1380	1585	1725	1160	1335	1450	740
SUH210-2	16	3 ¹ / ₈	8 ⁹ / ₁₆	2	1 ¹ / ₈	14	10dC or 16dC	6	10d Common	1930	2220	2415	1625	1870	2030	1115
SUH44	16	3 ⁹ / ₁₆	2 ⁷ / ₈	2	1 ¹ / ₈	6	10dC or 16dC	2	10d Common	830	950	1035	695	800	870	370
SUH46	16	3 ⁹ / ₁₆	4 ¹³ / ₁₆	2	1 ¹ / ₈	8	10dC or 16dC	4	10d Common	1105	1270	1380	930	1065	1160	740
SUH410	16	3 ⁹ / ₁₆	8 ³ / ₈	2	1 ¹ / ₈	14	10dC or 16dC	6	10d Common	1930	2220	2415	1625	1870	2030	1115
SUH414	16	3 ⁹ / ₁₆	10 ¹ / ₁₆	2	1 ¹ / ₈	16	10dC or 16dC	6	10d Common	2210	2540	2760	1855	2135	2320	1115
SUH44R	16	4	2 ¹¹ / ₁₆	2	1 ¹ / ₈	6	10dC or 16dC	2	16d Common	830	950	1035	695	800	870	440
SUH46R	16	4	4 ¹¹ / ₁₆	2	1 ¹ / ₈	8	10dC or 16dC	4	16d Common	1105	1270	1380	930	1065	1160	885
SUH410R	16	4	8 ⁹ / ₁₆	2	2	14	10dC or 16dC	6	16d Common	1930	2220	2415	1625	1870	2030	1325
SUH26-3	16	4 ⁵ / ₈	5 ¹ / ₄	2	1	8	10dC or 16dC	2	10d Common	1105	1270	1380	930	1065	1160	370
SUH210-3	16	4 ⁵ / ₈	8 ³ / ₈	2	1	14	10dC or 16dC	6	10d Common	1930	2220	2415	1625	1870	2030	1115
SUH66	16	5 ¹ / ₂	5	2	1	8	10dC or 16dC	4	10d Common	1105	1270	1380	930	1065	1160	740
SUH610	16	5 ¹ / ₂	9	2	1	14	10dC or 16dC	6	10d Common	1930	2220	2415	1625	1870	2030	1115
SUH66R	16	6	5	2	1	8	10dC or 16dC	4	16d Common	1105	1270	1380	930	1065	1160	885
SUH610R	16	6	9	2	1	14	10dC or 16dC	6	16d Common	1930	2220	2415	1625	1870	2030	1325

¹Allowable loads have been adjusted for load duration factors, C_D, as shown, in accordance with the NDS. The allowable loads do not apply to loads of other durations, and are not permitted to be adjusted for other load durations. See Sections 4.1 and 4.2 for design and installation requirements.

²See Section 3.19.3 and Table 3 for required fastener dimensions and mechanical properties. Allowable download

³Allowable loads shown are for installations in wood members complying with Section 3.19.2. Wood members must also have a reference compression perpendicular to grain design value, F_{c⊥}, of 625 psi (4.31 MPa) or greater.

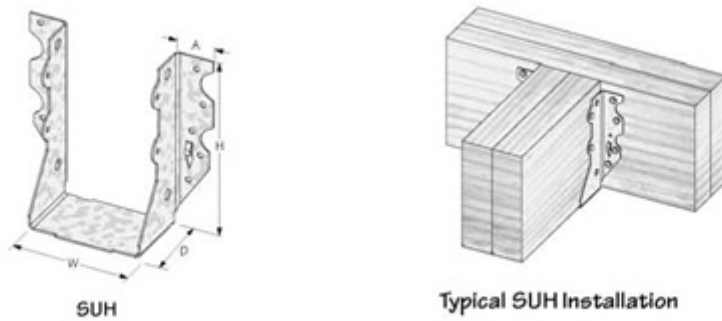

FIGURE 18—SUH JOIST HANGER

TABLE 21—TFI TOP MOUNT HANGER ALLOWABLE LOADS ^{1,2,3}

STOCK NO.	STEEL GAGE	DIMENSIONS (inches)				FASTENER SCHEDULE					ALLOWABLE LOADS (lbs)		
						Header			Joist		Download		
		W	H	D	TF	Top Qty	Min Face Qty	Type	Qty	Type	C _D = 1.0	C _D = 1.15	C _D = 1.25
TFI3516	16	2 ³ / ₈	16	2 ¹ / ₂	2 ¹ / ₁₆	4	2	16d Common	2	10dx1 ¹ / ₂	2560	2560	2560
TFI3518	16	2 ³ / ₈	18	2 ¹ / ₂	2 ¹ / ₁₆	4	2	16d Common	2	10dx1 ¹ / ₂	2560	2560	2560
TFI3520	16	2 ³ / ₈	20	2 ¹ / ₂	2 ¹ / ₁₆	4	2	16d Common	2	10dx1 ¹ / ₂	2560	2560	2560
TFI316	16	2 ⁹ / ₁₆	16	2 ¹ / ₂	2	4	2	16d Common	2	10dx1 ¹ / ₂	2560	2560	2560
TFI318	16	2 ⁹ / ₁₆	18	2 ¹ / ₂	2	4	2	16d Common	2	10dx1 ¹ / ₂	2560	2560	2560
TFI320	16	2 ⁹ / ₁₆	20	2 ¹ / ₂	2	4	2	16d Common	2	10dx1 ¹ / ₂	2560	2560	2560
TFI322	16	2 ⁹ / ₁₆	22	2 ¹ / ₂	2	4	6	16d Common	2	10dx1 ¹ / ₂	3245	3245	3245
TFI324	16	2 ⁹ / ₁₆	24	2 ¹ / ₂	2	4	6	16d Common	2	10dx1 ¹ / ₂	3245	3245	3245
TFI326	16	2 ⁹ / ₁₆	26	2 ¹ / ₂	2	4	6	16d Common	2	10dx1 ¹ / ₂	3245	3245	3245
TFI414	16	3 ⁹ / ₁₆	14	2 ¹ / ₂	2 ¹ / ₈	4	2	16d Common	2	10dx1 ¹ / ₂	2560	2560	2560
TFI416	16	3 ⁹ / ₁₆	16	2 ¹ / ₂	2 ¹ / ₈	4	2	16d Common	2	10dx1 ¹ / ₂	2560	2560	2560
TFI418	16	3 ⁹ / ₁₆	18	2 ¹ / ₂	2 ¹ / ₈	4	2	16d Common	2	10dx1 ¹ / ₂	2560	2560	2560
TFI420	16	3 ⁹ / ₁₆	20	2 ¹ / ₂	2 ¹ / ₈	4	2	16d Common	2	10dx1 ¹ / ₂	2560	2560	2560
TFI422	16	3 ⁹ / ₁₆	22	2 ¹ / ₂	2 ¹ / ₈	4	6	16d Common	2	10dx1 ¹ / ₂	3245	3245	3245
TFI424	16	3 ⁹ / ₁₆	24	2 ¹ / ₂	2 ¹ / ₈	4	6	16d Common	2	10dx1 ¹ / ₂	3245	3245	3245
TFI426	16	3 ⁹ / ₁₆	26	2 ¹ / ₂	2 ¹ / ₈	4	6	16d Common	2	10dx1 ¹ / ₂	3245	3245	3245

¹Allowable loads have been adjusted for load duration factors, C_D, as shown, in accordance with the NDS. The allowable loads do not apply to loads of other durations, and are not permitted to be adjusted for other load durations. See Sections 4.1 and 4.2 for design and installation requirements.

²See Section 3.19.3 and Table 3 for required fastener dimensions and mechanical properties. Allowable download

³Allowable loads shown are for installations in wood members complying with Section 3.19.2. Wood members must also have a reference compression perpendicular to grain design value, F_{c,⊥}, of 625 psi (4.31 MPa) or greater.

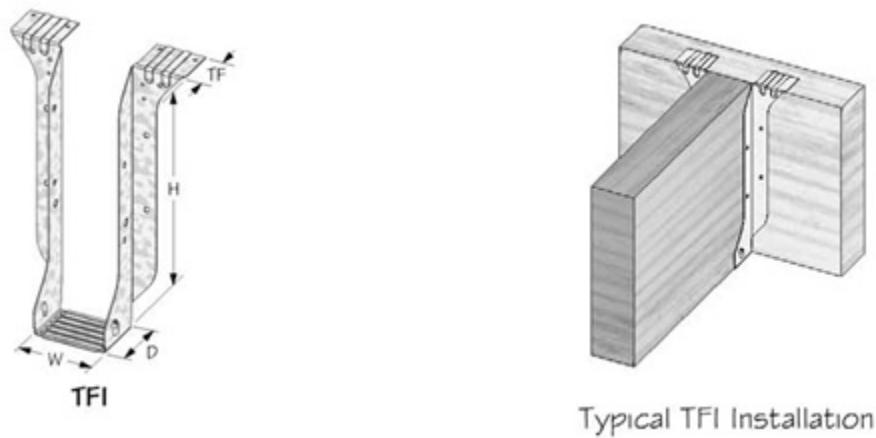

FIGURE 19—TFI TOP MOUNT HANGER

TABLE 22—STEEL TYPES AND CORROSION RESISTANCE

PRODUCT	STEEL	CORROSION PROTECTION
C Post Cap	ASTM A 653, SS designation, Grade 33	G90 ¹ , G185 ¹
D Post Anchor	ASTM A 653, SS designation, Grade 33	G90 ¹ , G185 ¹
HH Header Hanger	ASTM A 653, SS designation, Grade 33	G90 ¹
HL Light Gauge Purlin Hanger	ASTM A 653, SS designation, Grade 33	G90 ¹
KEG Glulam Beam Hanger	7 Gage material: ASTM A 1011, SS designation, Grade 33; 3 Gage material: ASTM A 36	Painted
KF Panel Hanger	ASTM A 653, SS designation, Grade 33	G90 ¹
KGH Floor Girder Hanger	ASTM A 1011, SS designation, Grade 33	Painted
KGLS Glulam Saddle Hanger/ KGLST Glulam Saddle Hanger	7 Gage material: ASTM A 1011, SS designation, Grade 33; 3 Gage material: ASTM A 36	Painted
KGLT Glulam Beam Hanger	7 Gage material: ASTM A 1011, SS designation, Grade 33; 3 Gage material: ASTM A 36	Painted
KHC Hinge Connector/ KHCST Seismic Strap	7 Gage material: ASTM A 1011, SS designation, Grade 33; 3 Gage material: ASTM A 36	Painted
KHGLS Glulam Saddle Hanger/ KHGLST Glulam Saddle Hanger	7 Gage material: ASTM A 1011, SS designation, Grade 33; 3 Gage material: ASTM A 36	Painted
KHGLT Glulam Beam Hanger	7 Gage material: ASTM A 1011, SS designation, Grade 33; 3 Gage material: ASTM A 36	Painted
KHHB Glulam Beam Hanger	ASTM A 1011, SS designation, Grade 33	Painted
KHSA Connector Strap	ASTM A 36	Painted
KHST Strap Tie	7 Gage material: ASTM A 1011, SS designation, Grade 33; 3 Gage material: ASTM A 36	Painted
KLEG Glulam Beam Hanger	ASTM A 1011, SS designation, Grade 33	Painted
KMEG Glulam Beam Hanger	ASTM A 1011, SS designation, Grade 33	Painted
KSA Connector Strap	ASTM A 653, SS designation, Grade 33	G90 ¹
KVB / KVBI Knee Brace	ASTM A 653, SS designation, Grade 33	G90 ¹
PHG Panel Hanger	ASTM A 653, SS designation, Grade 33	G90 ¹
SCA Stair Angle	ASTM A 653, SS designation, Grade 33	G185 ¹
SUH Joist Hanger	ASTM A 653, SS designation, Grade 33	G90 ¹
TFI Top Mount Hanger	ASTM A 653, SS designation, Grade 33	G90 ¹

For SI: 1 oz/ft² = 305 g/m².

¹Corrosion protection is a zinc coating in accordance with ASTM A 653.