



Report Number: 0201

Issued: 01/2012

Expires: 01/2013

Division: 06–WOOD AND PLASTICS
Section: 06090–Wood and Plastic Fastenings

Report Holder:
UNITED STEEL PRODUCTS COMPANY
14305 SOUTHCROSS DRIVE, SUITE 200
BURNSVILLE, MINNESOTA 55306
(952) 898-8772
www.uspconnectors.com

EVALUATION SUBJECT:

USP Structural Connectors for Wood-Framed Construction

1.0 EVALUATION SCOPE

1.1 Compliance with the following codes:

- 2009 International Building Code (IBC)
- 2009 International Residential Code (IRC)
- 2006 International Building Code (IBC)
- 2006 International Residential Code (IRC)

1.2 Evaluated in accordance with

- ICC-ES AC13 Approved October 2010,

1.3 Property evaluated

- Structural

2.0 USES

The USP structural connectors described in this report are used for connecting wood framing members in accordance with Section 2304.9 of the IBC. They may also be used in structures regulated under the IRC when an engineered design is submitted in accordance with IRC Section R301.1.3.

3.0 GENERAL DESCRIPTION

3.1 Product information:

3.1.1 CSH Concealed Stringer Hanger: The CSH-TZ stringer hanger provides a concealed connection for attaching the stair stringer to the carrying member. The CSH-TZ is fabricated from No. 18 gage steel and is

prepunched for 10d-by-1-1/2-inch nails into header, and 10d-by-1-1/2-inch nails into the stair stringer. See Table 1 and Figure 1 for stock number, product dimensions, fastener schedule and allowable loads.

3.1.2 HDQIF Face Mount Inverted Flange Hangers:

The HDQIF Face Mount Inverted Flange Hanger is designed to support headers, joists and trusses. The HDQIF Face Mount Hanger is cold-formed from No. 14 gage steel; and is prepunched for 1/4" x 3" wood screws into supporting member, and either 1/4" x 1-1/2" wood screws or 1/4" x 3" wood screws into the supported member. See Table 2 and Figure 2 for stock numbers, product dimensions, fastener schedule, and allowable loads.

3.1.3 HTC4 Heavy Truss Clip:

The HTC4 Heavy Truss Clip provides lateral support for non-load bearing walls while allowing floor and roof trusses to deflect. The HTC4 is cold-formed from No. 16 gage steel; and is prepunched for 10d-by-1-1/2-inch nails into plate and 10d-by-1-1/2-inch nails into the truss/rafter. See Table 3 and Figure 3 for stock number, product dimensions, fastener schedule and allowable loads.

3.1.4 JDS Purlin Hangers:

The JDS Purlin Hanger is designed for purlin applications to provide double shear nailing. The JDS Purlin Hanger is cold-formed from No. 18 gage steel; and is prepunched for 10d-by-1-1/2-inch nails into header and 10d common nail into the joist. See Table 4 and Figure 4 for stock numbers, product dimensions, fastener schedule, and allowable loads.

3.1.5 JLIF Inverted Flange Joist Hangers:

The JLIF Inverted Flange Joist Hanger is designed as a face-mount hanger to support nominal dimension joists. The JLIF is cold-formed from 18 gage steel; and is prepunched for 10d or 16d common nails into the header and 10d-by-1-1/2-inch nails into the joist. See Table 5 and Figure 5 for stock numbers, product dimensions, fastener schedule, and allowable loads.

3.1.6 LJC Lateral Joist Connector:

The LJC-TZ Lateral Joist Connector transfers lateral loads at the top foundation to the floor joists. The LJC-TZ is cold-formed from No. 18 gage steel and fastens the top side of the sill plate to the underside of the floor joist with 8d-by-1-1/2-inch nails. See Table 6 and Figure 6 for stock number product dimensions, fastener schedule, and allowable loads.

Report Number: 0201

Issued: 01/2012

Expires: 01/2013

3.1.7 LJQ Lateral Joist Connectors: The LJQ Lateral Joist Connectors transfers lateral loads at the top foundation to the floor joists. The LJQ Lateral Joist Connector is cold-formed from 16 gage steel; and is prepunched for ¼" x 1-1/2" wood screws. See Table 7 and Figure 7 for stock numbers, product dimensions, fastener schedule, and allowable loads.

3.1.8 MUS Slant Nail Joist Hangers: The MUS Slant Nail Joist Hanger is designed for face-mount applications to provide double shear nailing for joist/truss-to-beam connections. The MUS Slant Nail Joist Hanger is cold-formed from 18 gage steel and is prepunched for 10d common nails into both the header and the joist. See Table 8 and Figure 8 for stock numbers, product dimensions, fastener schedule, and allowable loads.

3.1.9 RBC Roof Boundary Clip: The RBC Roof Boundary Clip is designed to connect roof blocking to a wall top plate for a lumber connection having an angle ranging from 0 to 45 degrees. The RBC Roof Boundary Clip is cold-formed from 20 gage steel and is prepunched for 10d-by-1-1/2-inch nails into the top plate and 10d-by-1-1/2-inch nails into the blocking. See Table 9 and Figure 9 for stock numbers, product dimensions, fastener schedule, and allowable loads.

3.2 Materials:

3.2.1 Steel: The specific types of steel and corrosion protection for each product are described in Table 10 of this report. Minimum steel base-metal thicknesses for the different gages are shown in the following table:

GAGE NO.	MINIMUM BASE-METAL THICKNESS (inch)
20	0.033
18	0.044
16	0.055
14	0.070

For SI: 1 inch = 25.4 mm.

3.2.2 Wood: Wood members must be sawn lumber or structural glued laminated timber with a minimum specific gravity of 0.50, or approved structural engineered lumber (structural composite lumber, alternative strand lumber, or prefabricated wood I-joists) with a minimum equivalent specific gravity of 0.50,

unless otherwise noted in the applicable table within this report. Wood members must have a moisture content not exceeding 19 percent (16 percent for structural engineered lumber), except as noted in Section 4.1. For connectors installed with nails, the thickness of each wood member must be sufficient such that the specified fasteners do not protrude through the opposite side of the member, unless otherwise permitted in the applicable table within this report. Wood members that are structural engineered lumber must be recognized in, and used in accordance with, a current evaluation report. Refer to 3.2.5 for issued related to treated wood.

3.2.3 Fasteners: Required fastener types and sizes for use with the USP structural connectors described in this report are specified in this section and Tables 1 through 9.

3.2.4 Nails: Nails used for connectors described in this report must comply with material requirements, physical properties, tolerances, workmanship, protective coating and finishes, and packaging and package marking requirements specified in ASTM F 1667; and must have lengths, diameters and bending yield strengths, F_{yb} , as shown in the following table:

FASTENER DESIGNATION	FASTENER LENGTH (inches)	SHANK DIAMETER (inch)	MINIMUM REQUIRED F_{yb} (Ibf/in ²)
8d x 1½	1.5	0.131	100,000
10d x 1½	1.5	0.148	90,000
10d common	3.0	0.148	90,000
16d common	3.5	0.162	90,000
WS15	1.5	0.242	180,000
WS15-GC	1.5	0.242	180,000
WS3	3.0	0.242	180,000

For SI: 1 inch = 25.4 mm, 1 psi = 6.89 kPa.

3.2.5 Use in Treated Wood: Connectors and fasteners used in contact with preservative-treated or fire-retardant-treated wood must comply with IBC Section 2304.9.5, Section R319.3 of the 2006 IRC, or Section R317.3 of the 2009 IRC. The lumber treater or the report holder (United Steel Products Company), or both, should be contacted for recommendations on the appropriate level of corrosion resistance to specify for the connectors and fasteners as well as the connection capacities of the fasteners used with the specific

Report Number: 0201

Issued: 01/2012

Expires: 01/2013

proprietary preservative-treated or fire-retardant-treated lumber.

4.0 DESIGN AND INSTALLATION

4.1 Design:

The allowable load capacities in Tables 1 through 10 are based on allowable stress design. The use of the allowable load values for the products described in this report must comply with all applicable requirements and conditions specified in this report. Tabulated allowable loads are for normal duration or short duration, or both, based on load durations factors, C_D , in accordance with Section 10.3.2 of the NDS. No further increases are permitted for load durations other than those specified. Tabulated allowable loads are for connections in wood seasoned to a maximum moisture content of 19 percent (16 percent for engineered wood products) or less, used under continuously dry conditions and where sustained temperatures are limited to 100°F (37.8°C) or less. When connectors are installed in wood having a moisture content greater than 19 percent (16 percent for engineered wood products), or where the in-service moisture content is expected to exceed this value, the applicable wet service factor, C_M , specified in Section 10.3.3 of the NDS must be applied. Unless otherwise noted in the tables of this report, the applicable wet service factor, C_M , is as specified in the NDS for lateral loading of dowel-type fasteners. When connectors are installed in wood that will experience sustained exposure to temperatures exceeding 100°F (37.8°C), the allowable loads in this evaluation report must be adjusted by the temperature factor, C_t , specified in Section 10.3.4 of the NDS. The group action factor, C_g , has been accounted for, in accordance with Section 10.3.6 of the NDS in the tabulated allowable loads, where applicable.

For connectors with anchors intended to transmit loads into concrete or masonry, adequate embedment length and anchorage details, including edge and end distances, must be determined by a licensed design professional in accordance with Chapter 19 or 21 of the IBC as applicable, for design of anchorage to concrete and masonry structural members.

Where design load combinations include earthquake loads or effects, the design strength of anchorage to concrete must be determined in accordance with Section 1912 of the IBC, except for detached one- and two-

family dwellings, assigned to Seismic Design Category A, B or C, or located where the mapped short-period spectral response acceleration, S_s , is less than 0.4g.

4.2 Installation:

Installation of the connectors must be in accordance with this evaluation report and the manufacturer's published installation instructions. Mechanical fasteners must be installed in wood members in accordance with NDS Section 11.1.

4.3 Special Inspection:

4.3.1 IBC Wind: Periodic special inspection is required for installation of connectors described in this report that are designated as components within the main-wind-force-resisting-system of structures constructed when required in accordance with 2009 IBC Section 1706.1 (Section 1705.1 of the 2006 IBC). Special inspection requirements do not apply to structures, or portions thereof, that qualify for exception under the 2009 IBC Section 1704.1, 1704.4, 1706.2 or 1706.3 (Section 1704.1 and 1704.4 of the 2006 IBC).

4.3.2 IBC Seismic: Periodic special inspection is required for installation of connectors described in this report that are designated as components of the seismic-force-resisting-system for structures in Seismic Design Category C, D, E or F in accordance with IBC Section 1707.3 or 1707.4, with the exception of those structures that qualify under the Exceptions to Section 1704.1.

4.3.3 IRC: Special inspections are not required for connectors used in structures regulated under the IRC.

5.0 CONDITIONS OF USE

The USP structural connectors described in this report comply with, or are suitable alternatives to what is specified in, those codes listed in Section 1.0 if this report, subject to the following conditions:

5.1 The connectors must be manufactured, identified and installed in accordance to this report and the manufacturer's published installation instructions. A copy of the manufacturer's published installation instructions must be available at the jobsite at all times during installation.

Report Number: 0201

Issued: 01/2012

Expires: 01/2013

5.2 Calculations showing compliance with this report must be submitted to the code official. The calculations must be prepared by a licensed design professional where required by the statutes of the jurisdiction in which the project is to be constructed.

5.3 Connected wood members and fasteners must comply with Sections 3.2.2 and 3.2.3, respectively.

5.4 Adjustment factors, noted in Section 4.1 of this report and the applicable codes, must be considered in the design of the connections where applicable.

5.5 Use of connectors and fasteners with preservative-treated or fire-retardant-treated lumber must be in accordance with Section 3.2.5.

5.6 The design of the anchorage to, and bearing upon, concrete or masonry construction, inclusive of cast-in-place and post-installed anchors, used to attach the connectors described in this report to concrete or masonry construction, is outside of the scope of this report.

6.0 EVIDENCE SUBMITTED

Testing and analysis data submitted is in compliance with ICC-ES Acceptance Criteria, AC13, Acceptance Criteria for Joist Hangers And Similar Devices effective November 1, 2010. Test results are from laboratories in compliance with ISO/IEC 17025.

7.0 IDENTIFICATION

Each connector described in this report is identified by the product model (stock) number, the number of the IAPMO index evaluation report for United Steel Products (ER-0201) which identifies the products listed in this report, IAPMO ES Mark of Conformity, and by one or more of the following designations: USP or United Steel Products Company.



IAPMO #0201

A handwritten signature in black ink, appearing to be a stylized name.

Director of Evaluation Services

EVALUATION REPORT



Report Number: 0201
Issued: 01/2012
Expires: 01/2013

TABLE 1: CSH-TZ CONCEALED STRINGER HANGER ALLOWABLE LOADS

STOCK NUMBER	STEEL GAUGE	DIMENSIONS (inches)				FASTENER SCHEDULE ¹				ALLOWABLE LOADS (lbs.)		
		JOIST W	HANGER			HEADER		JOIST		DF-L/SP		
			W	H	D	Qty	Type	Qty	Type	100%	115%	125%
CSH-TZ	18	1 1/2	1 7/16	5	5	8	10dx1-1/2	5	10d x 1 1/2	890	890	890

For SI: 1 inch = 25.4 mm, 1 lbf = 4.45 N, 1 psi = 6.89 kPa

¹A 10d x 1 1/2 nail is 1 1/2 inches long and 0.148 inches in diameter.

²The CSH-TZ is designed to support stair stringers and has not been torsionally tested for support of floor and roof framing members.

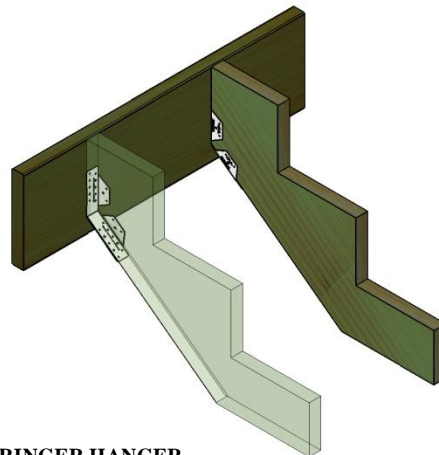
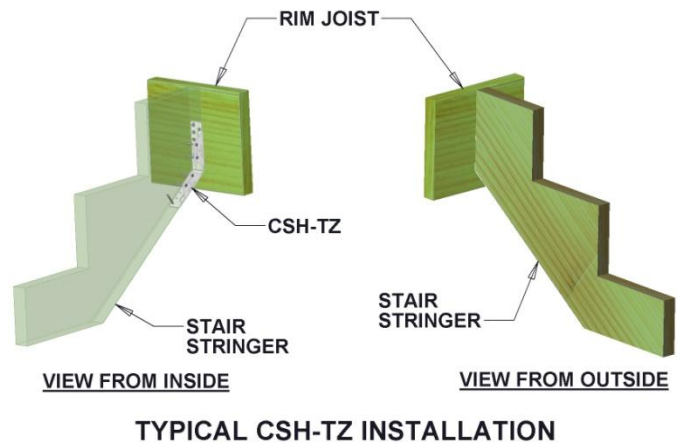
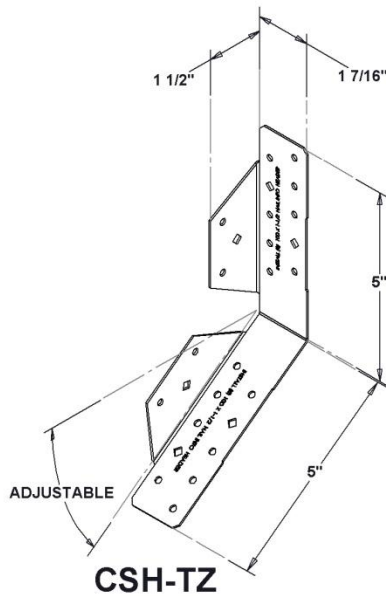

FIGURE 1 – CSH-TZ CONCEALED STRINGER HANGER

EVALUATION REPORT



Report Number: 0201
 Issued: 01/2012
 Expires: 01/2013

TABLE 2: HDQIF FACE MOUNT INVERTED FLANGE HANGERS ALLOWABLE LOADS

STOCK NO.	STEEL GA.	DIMENSIONS (inches)			FASTENER SCHEDULE ^{1,2}				ALLOWABLE LOADS (lbs.) ³						
		W	H	D	Header		Joist		F _{CL} = 560 psl			F _{CL} = 625 psl			Uplift
					Qty	Type	Qty	Type	100%	115%	125%	100%	115%	125%	
HDQ179IF	14	1 ¹³ / ₁₆	9	3	8	WS3	4	WS15	3340	3605	3605	3340	3605	3605	1110
HDQ17112IF	14	1 ¹³ / ₁₆	11	3	10	WS3	6	WS15	3340	3340	3340	3340	3340	3340	1580
HDQ1714IF	14	1 ¹³ / ₁₆	13 ¹ / ₈	3	12	WS3	6	WS15	4320	4525	4665	4660	4870	4955	2035
HDQ310IF	14	2 ⁹ / ₁₆	9	3	8	WS3	4	WS15	3340	3605	3605	3340	3605	3605	1110
HDQ210-2IF	14	3 ¹ / ₄	9	3	12	WS3	6	WS3	5015	5590	5590	5015	5590	5590	2975
HDQ410IF	14	3 ⁹ / ₁₆	9	3	12	WS3	6	WS3	5015	5590	5590	5015	5590	5590	2975
HDQ412IF	14	3 ⁹ / ₁₆	11	3	14	WS3	6	WS3	5605	5605	5605	5605	5605	5605	3280
HDQ210-3IF	14	4 ⁵ / ₈	9	3	12	WS3	6	WS3	5015	5590	5590	5015	5590	5590	2975
HDO5210IF	14	5 ¹ / ₄	9	3	12	WS3	6	WS3	5015	5590	5590	5015	5590	5590	2975
HDQ5212IF	14	5 ¹ / ₄	11	3	14	WS3	6	WS3	5605	5605	5605	5605	5605	5605	3280
HDQ610IF	14	5 ¹ / ₂	9	3	12	WS3	6	WS3	5015	5590	5590	5015	5590	5590	2975
HDQ612IF	14	5 ¹ / ₂	11	3	14	WS3	6	WS3	5605	5605	5605	5605	5605	5605	3280

FOR SI: 1 inch = 25.4 mm, 1 lbf = 4.45 N, 1 psi = 6.89 kPa

¹ A WS15 is a 1/4" x 1 1/2" long self-drilling wood screw sold by USP and is included with each hanger.

² A WS3 is a 1/4" x 3" long self-drilling wood screw sold by USP and is included with each hanger.

³ Loads have been increased as shown in accordance with code.

15% and 25% for snow and construction loads. No further increase is permitted.
 60% for wind or seismic loading. No further increase is permitted.

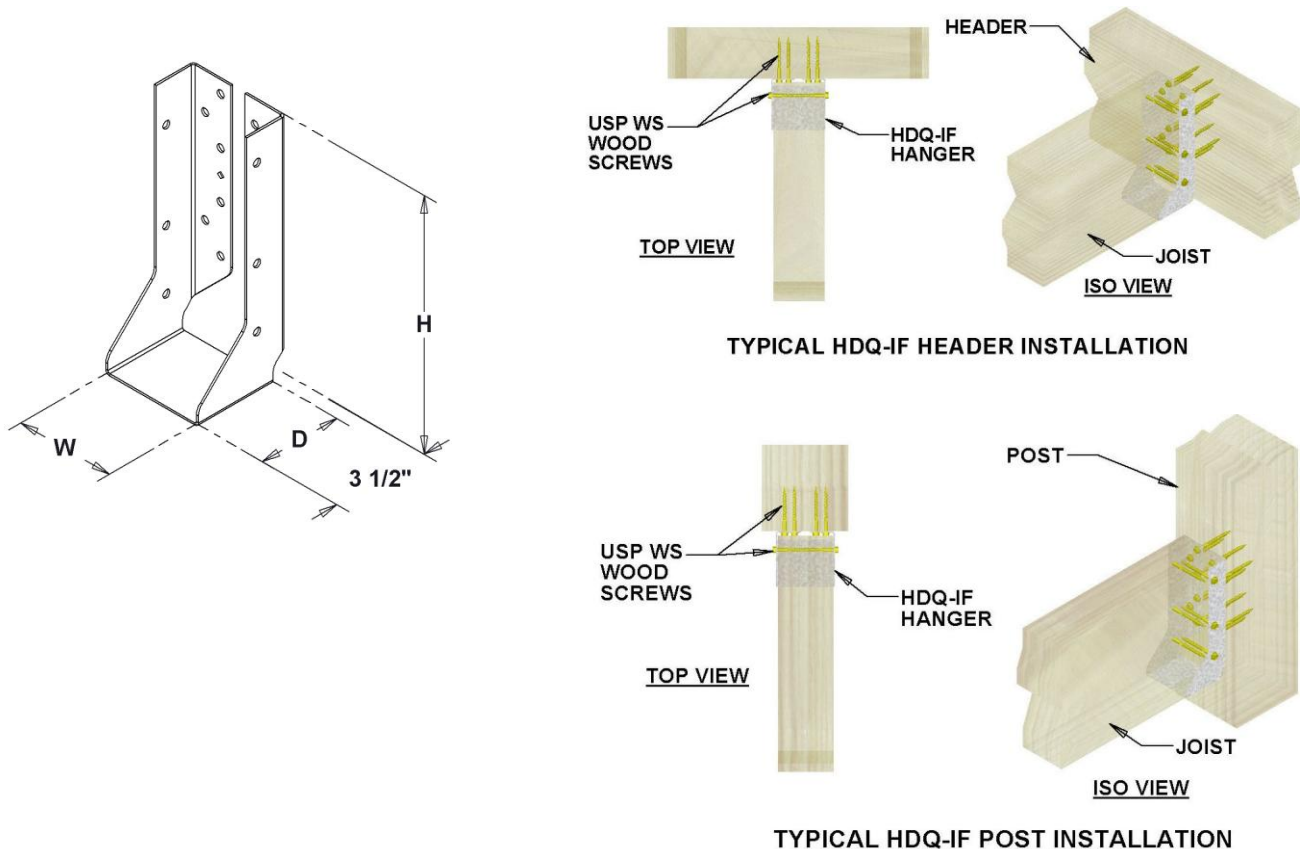

FIGURE 2 – HDQIF FACE MOUNT INVERTED FLANGE HANGERS

EVALUATION REPORT



Report Number: 0201
Issued: 01/2012
Expires: 01/2013

TABLE 3: HTC HEAVY TRUSS CLIP ALLOWABLE LOADS

STOCK NO.	STEEL GA	DIMENSIONS (in.)				FASTENER SCHEDULE ¹					ALLOWABLE LOADS (lbs.) ²			
		W	H	L	D	Plate			Truss/Rafter		Without Gap ³		With 1 1/4" Gap ⁴	
						Top Qty.	Side Qty.	Type	Qty	Type	F1	F2	F1	F2
HTC4	16	3 1/2	3 1/4	1 15/16	1	2	4	10d x 1 1/2"	3	10d x 1 1/2"	255	525	55	295

For SI: 1 inch = 25.4 mm, 1 lbf = 4.45 N, 1 psi = 6.89 kPa

¹ A 10d x 1 1/2" nail has a diameter of 0.148 inches (9 ga.) and length of 1 1/2 inches.

² Loads have been increased 60% for wind or seismic loads. No further increase shall be permitted.

³ Truss/Rafter must be bearing on top plate to achieve the allowable loads under "Without Gap"

⁴ When installed with maximum 1 1/4" space between truss/rafter and top plate, use loads under "With 1 1/4" Gap"

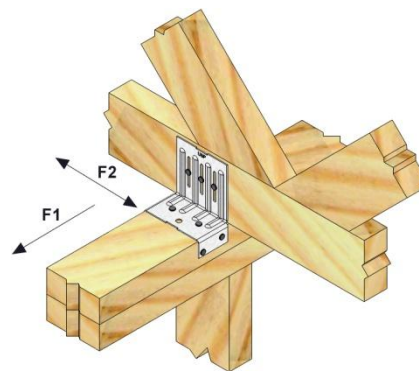
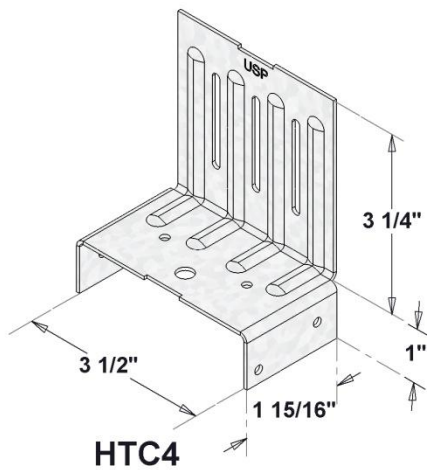

TYPICAL HTC4 INSTALLATION

EVALUATION REPORT



Report Number: 0201
Issued: 01/2012
Expires: 01/2013

JDS PURLIN HANGER SERIES

STOCK NO.	STEEL GA.	DIMENSIONS (inches)				PURLIN(S)		FASTENER SCHEDULE ^{1,2}					ALLOWABLE LOADS (lbs.) ^{3,4}			
		W	H	D	TF	Qty	Size	Header			Joist		F _C = 625 psi			
								Top	Face	Type	Qty	Type	100%	115%	125%	160%
JDS24S	18	1 ⁹ / ₁₆	3 ¹ / ₂	1 ¹ / ₄	³ / ₄	1	2 x 4	2	0	10dx1-1/2	2	10d Common	575	575	575	340
JDS24	18	1 ⁹ / ₁₆	3 ¹ / ₂	1 ¹ / ₄	1 ⁹ / ₁₆	2	2 x 4	4	0	10dx1-1/2	2	10d Common	1155	1155	1155	680
JDS26S	18	1 ⁹ / ₁₆	5 ¹ / ₂	1 ¹ / ₄	³ / ₄	1	2 x 6	2	0	10dx1-1/2	4	10d Common	775	830	835	390
JDS26	18	1 ⁹ / ₁₆	5 ¹ / ₂	1 ¹ / ₄	1 ⁹ / ₁₆	2	2 x 6	4	0	10dx1-1/2	4	10d Common	1575	1670	1670	775

For SI: 1 inch = 25.4 mm, 1 lbf = 4.45 N, 1 psi = 6.89 kPa.

¹A 10d x 1¹/₂ nails has a diameter of 0.148 inch and a length of 1¹/₂ inches.

²A 10d common nail has a diameter of 0.148 inch and a length of 3 inches.

³The listed loads assume the supporting member is not less than 1¹/₂ inches thick.

⁴Loads have been increased as shown in accordance with code.

15% and 25% for snow and construction loads. No further increase is permitted.
 60% for wind or seismic loading. No further increase is permitted.

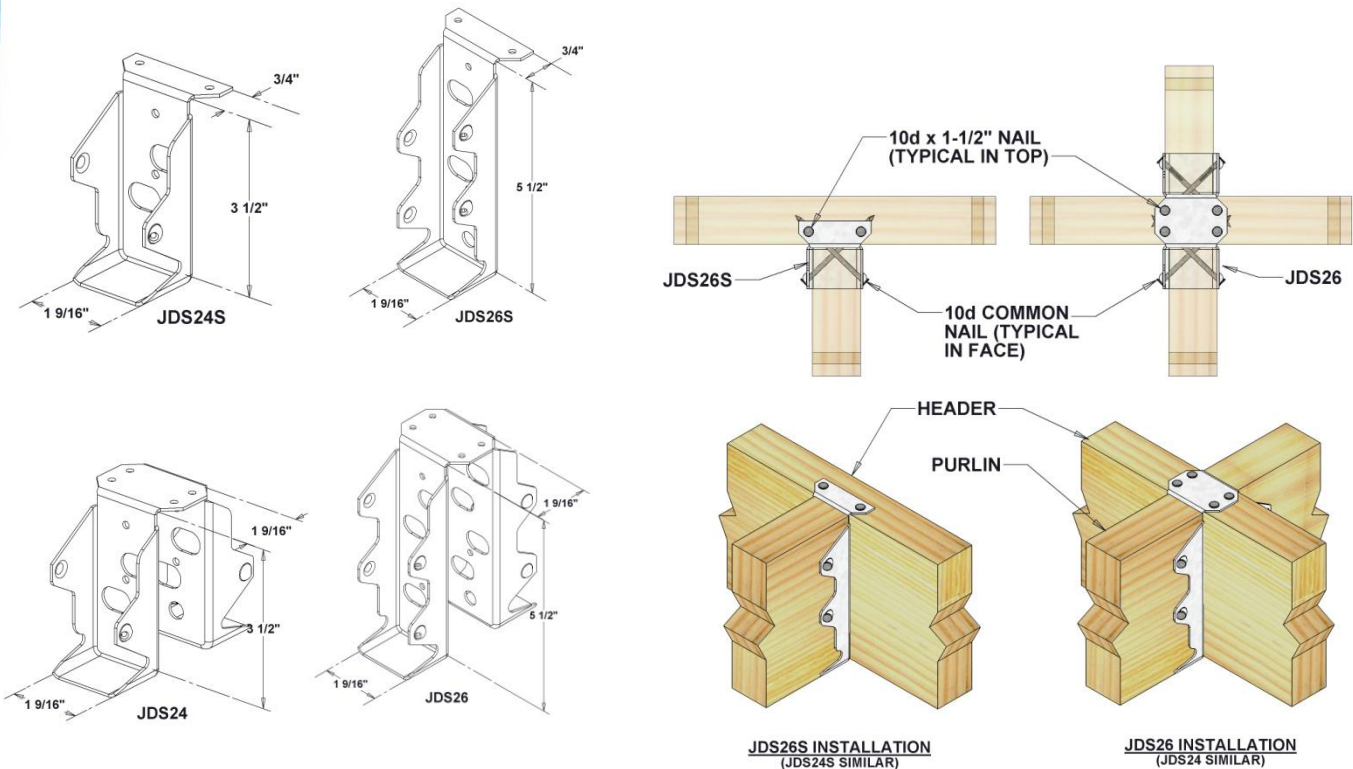

TYPICAL JDS PURLIN HANGER INSTALLATION

FIGURE 4 – JDS PURLIN HANGERS

EVALUATION REPORT



Report Number: 0201
Issued: 01/2012
Expires: 01/2013

JL-IF INVERTED FLANGE HANGER SERIES

STOCK NUMBER	STEEL GAGE	DIMENSIONS (in.)			FASTENER SCHEDULE ^{1 2 3}				ALLOWABLE LOADS (lbs.) ⁴			
					Header		Joist		DF-L/SP			
		W	H	D	Nail Qty	Nail Type	Nail Qty	Nail Type	100%	115%	125%	Uplift 160%
JL24-IF	18	1 ⁹ / ₁₆	3 ¹ / ₈	1 ¹ / ₂	4	10d Common	2	10dx1 ¹ / ₂	465	535	580	280
					4	16d Common	2	10dx1 ¹ / ₂	550	615	615	280
JL26-IF	18	1 ⁹ / ₁₆	4 ¹ / ₂	1 ¹ / ₂	6	10d Common	4	10dx1 ¹ / ₂	695	800	870	730
					6	16d Common	4	10dx1 ¹ / ₂	830	950	1035	730
JL28-IF	18	1 ⁹ / ₁₆	6 ¹ / ₈	1 ¹ / ₂	8	10d Common	4	10dx1 ¹ / ₂	930	1065	1160	730
					8	16d Common	4	10dx1 ¹ / ₂	1105	1215	1215	730
JL210-IF	18	1 ⁹ / ₁₆	8 ¹ / ₄	1 ¹ / ₂	11	10d Common	6	10dx1 ¹ / ₂	1275	1465	1595	1095
					11	16d Common	6	10dx1 ¹ / ₂	1520	1745	1900	1095

For SI: 1 inch = 25.4 mm, 1 lbf = 4.45 N, 1 psi = 6.89 kPa

¹ A 10d Common nail is .0148 inches in diameter and 3 inches long

² A 16d Common nail is .0162 inches in diameter and 3¹/₂" inches long

³ A 10dx1¹/₂" nail is .0148 inches in diameter and 1¹/₂" inches long

⁴ Loads have been increased as shown in accordance with code.

15% and 25% for snow and construction loads. No further increase is permitted.

60% for wind or seismic loading. No further increase is permitted.

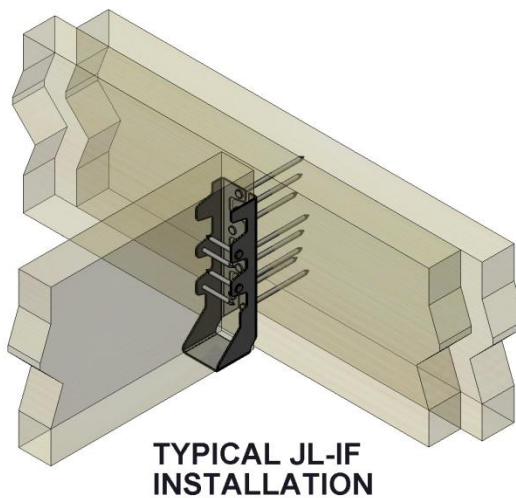
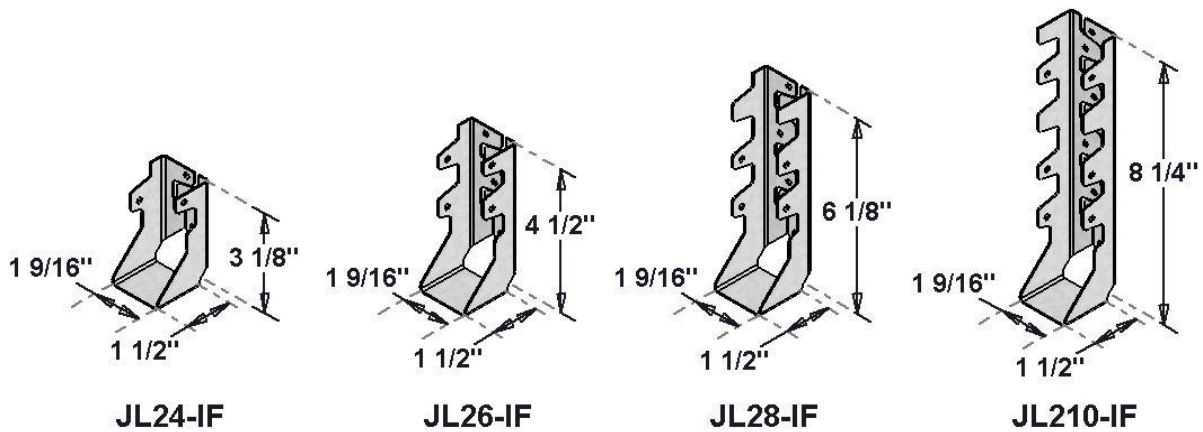

**TYPICAL JL-IF
INSTALLATION**

FIGURE 5 – JLIF-TZ INVERTED FLANGE JOIST HANGERS

EVALUATION REPORT



Report Number: 0201
Issued: 01/2012
Expires: 01/2013

TABLE 6: LJC-TZ LATERAL JOIST CONNECTOR ALLOWABLE LOADS

STOCK NUMBER	STEEL GAGE	FASTENER SCHEDULE				DF-L/SP ALLOWABLE LOADS (lbs.) ¹		
		LJC to Joist		LJC to Plate		Compression		
		Qty	Type ²	Qty	Type ²	90%	100%	160%
LJC-TZ	18	6	8d x 1 ¹ / ₂	6	8d x 1 ¹ / ₂	515	570	670

For SI: 1 inch = 25.4 mm, 1 lbf = 4.45 N, 1 psi = 6.98 kPa

¹ Loads have been decreased or increased as shown in accordance with code.

90% for earth loading

60% for wind or seismic loading. No further increase is permitted.

² A 8d x 1-1/2 nail has a diameter of 0.131 inch and a length of 1-1/2 inches.

³ All nails must be installed with sufficient edge distances to prevent splitting of member.

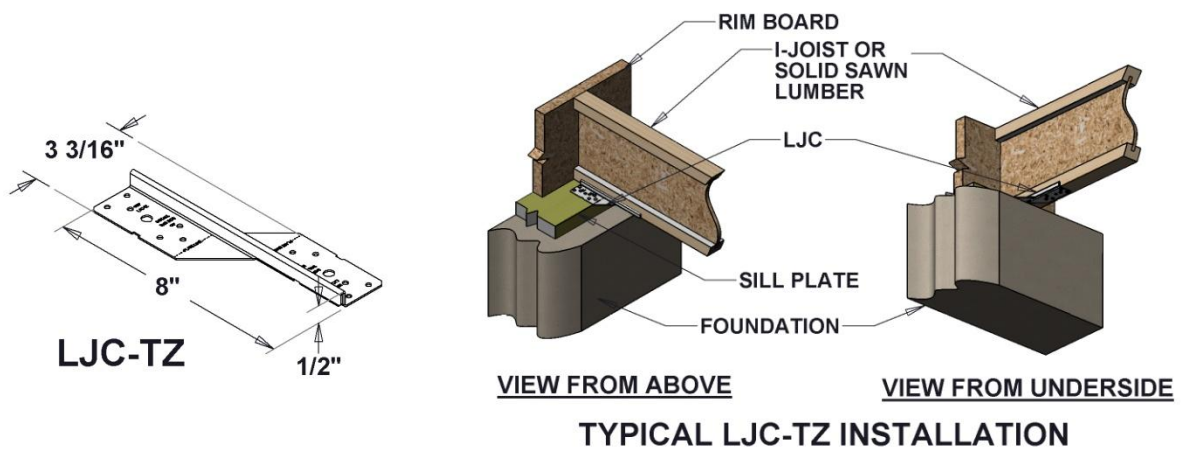

FIGURE 6 – LJC-TZ LATERAL JOIST CONNECTOR

EVALUATION REPORT



Report Number: 0201
Issued: 01/2012
Expires: 01/2013

TABLE 7: LJQ-TZ LATERAL JOIST CONNECTOR ALLOWABLE LOADS

STOCK NUMBERS	STEEL GAGE	DIMENSIONS (inches)			FASTENER SCHEDULE				SOUTHERN PINE SILL PLATE ALLOWABLE COMPRESSION		
		Width (in.)	Length (in.)	Depth (in.)	LJQ to Joist		LJQ to Plate		90%	100%	160%
					Qty	Type	Qty	Type ²			
LJQ15-TZ	16	1 ⁹ / ₁₆	3	1 ¹ / ₂	--	--	4	WS15-GC	915	1015	1110
LJQ17-TZ	16	1 ¹³ / ₁₆	3	1 ¹ / ₂	--	--	4	WS15-GC	915	1015	1110
LJQ20-TZ	16	2 ¹ / ₈	3	1 ¹ / ₂	--	--	4	WS15-GC	915	1015	1110
LJQ23-TZ	16	2 ⁵ / ₁₆	3	1 ¹ / ₂	--	--	4	WS15-GC	915	1015	1110
LJQ25-TZ	16	2 ⁹ / ₁₆	3	1 ¹ / ₂	--	--	4	WS15-GC	915	1015	1110
LJQ35-TZ	16	3 ⁹ / ₁₆	3	1 ¹ / ₂	--	--	4	WS15-GC	915	1015	1260

For SI: 1 inch = 25.4 mm, 1 lbf = 4.45 N, 1 psi = 6.98 kPa

¹ Loads have been decreased or increased as shown in accordance with code.

90% for earth loading

60% for wind or seismic loading. No further increase is permitted.

² WS15-GC wood screws are 1/4" diameter x 1-1/2" long and are included with connector.

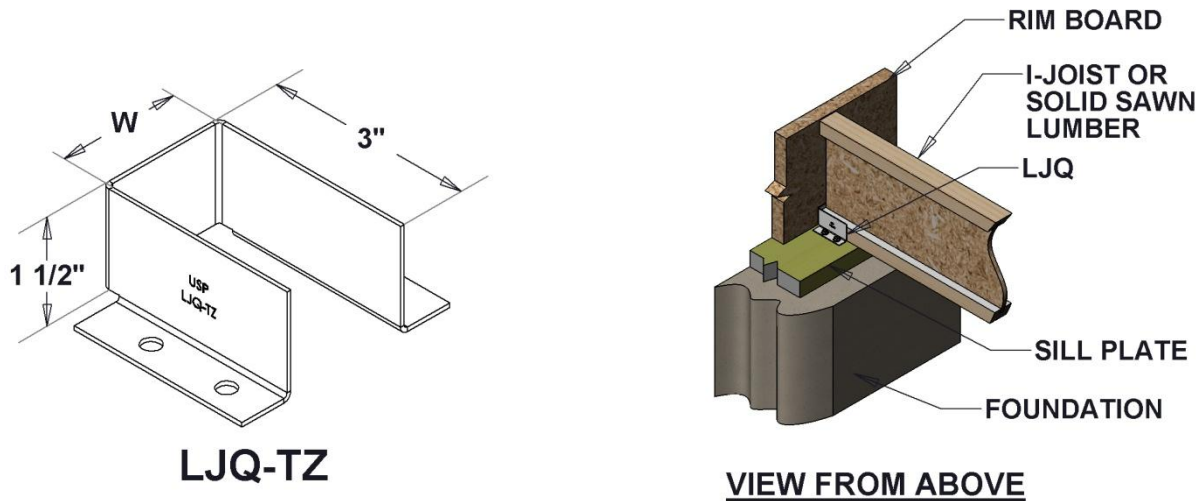

VIEW FROM ABOVE
TYPICAL LJQ-TZ INSTALLATION

FIGURE 7 – LJQ-TZ LATERAL JOIST CONNECTOR

Report Number: 0201
Issued: 01/2012
Expires: 01/2013

TABLE 8: MUS SLANT NAIL JOIST HANGER ALLOWABLE LOADS

STOCK NUMBER	STEEL GA.	DIMENSIONS (in.)				FASTENER SCHEDULE ^{1 2}				DF-L/SP ALLOWABLE LOADS (lbs.)			
		W	H	D	A	Header		Joist		Downward ³			Uplift ³
						Qty	Type	Qty	Type	100%	115%	125%	160%
MUS26	18	1 ⁹ / ₁₆	5 ¹ / ₁₆	2	1	6	10d Common	6	10d Common	1285	1475	1605	865
MUS28	18	1 ⁹ / ₁₆	7 ¹ / ₁₆	2	1	8	10d Common	8	10d Common	1710	1970	2140	1230

For SI: 1 inch = 25.4 mm, 1 lbf = 4.45 N, 1 psi = 6.89 kPa

¹ A 10d Common nail is 3 inches long and 0.148 inches in diameter

² The 10d Common nails driven into the joist shall be installed at 30 to 45 degrees horizontally toward the header.

³ Loads have been increased as shown in accordance with code.

15% and 25% for snow and construction loads. No further increase is permitted.
 60% for wind or seismic loading. No further increase is permitted.

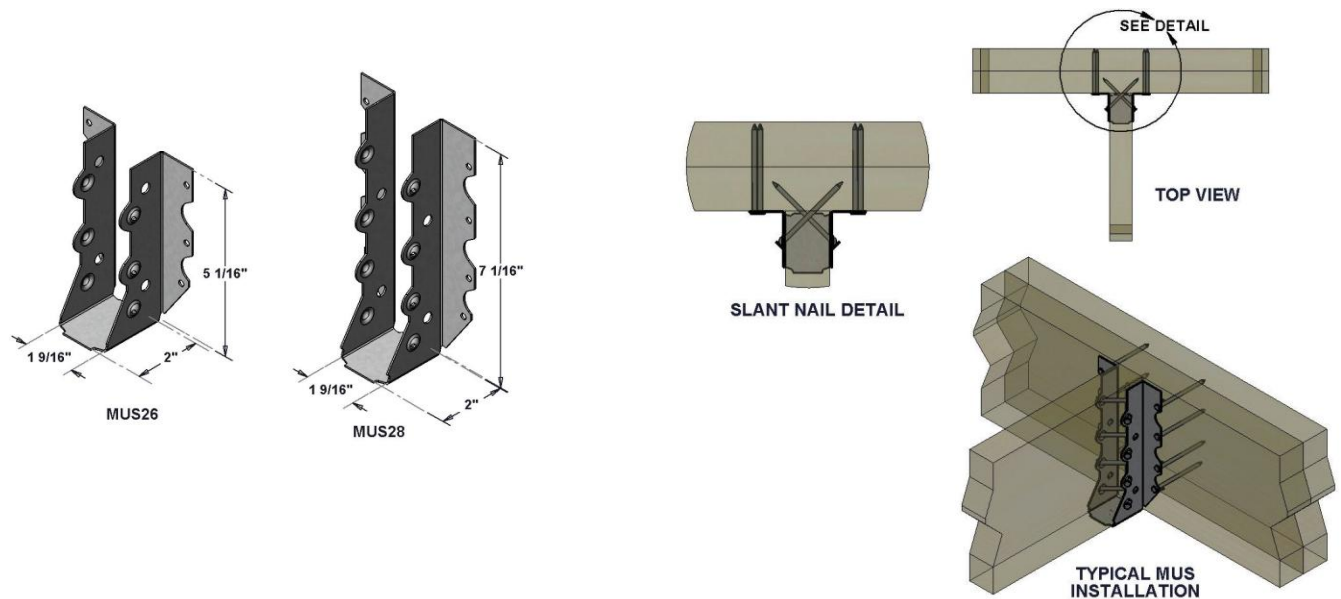

FIGURE 8 – MUS SLANT NAIL JOIST HANGERS

EVALUATION REPORT



Report Number: 0201

Issued: 01/2012

Expires: 01/2013

TABLE 9: RBC ROOF BOUNDARY CLIP ALLOWABLE LOADS

STOCK NUMBER	STEEL GAGE	INSTALLATION CONFIGURATION	FASTENER SCHEDULE ²				Load ⁴ Direction	ALLOWABLE LOADS (lbs.) ³			
			Header / Stud		Joist / Plate			100%	115%	125%	160%
RBC	20	Wood to Wood	6	10d x 1 1/2"	6	10d x 1 1/2"	F1	525	525	525	525
RBC	20	Wood to CMU	3	1/4" x 1 1/2" Tapcon	6	10d x 1 1/2"	F1	450	450	450	450

FOR SI: 1 inch = 25.4 mm, 1lbf = 4.45 N, 1 psi = 6.89 kPa

¹ Refer to drawings for installation configuration.

² A 10d x 1 1/2" nail has a diameter of 0.148 inches and length of 1 1/2 inches.

1/4" x 1 1/2" Tapcons are manufactured by ITW-Buildex

³ Allowable loads have been increased 15% for snow load, 25% for construction loads and 60% for wind or seismic loads. No further increase is permitted.

⁴ Refer to installation drawings for the load direction.

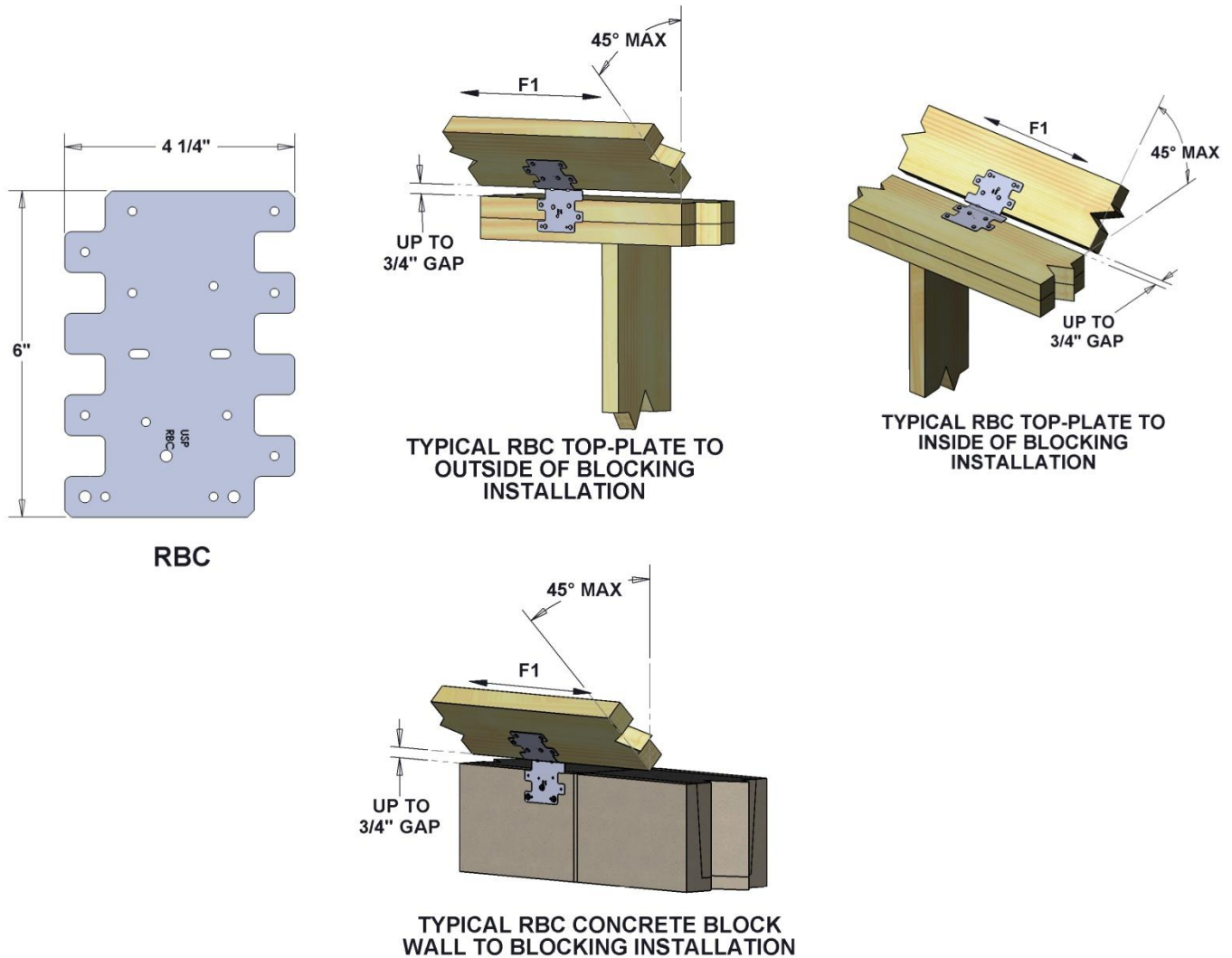

FIGURE 9 – RBC ROOF BOUNDARY CLIP
Page 13 of 14

EVALUATION REPORT



Report Number: 0201
Issued: 01/2012
Expires: 01/2013

TABLE 10: STEEL, TYPE, STRENGTH, AND CORROSION RESISTANCE

PRODUCT	STEEL ^{2,3}	COATING ¹
CSH-TZ Concealed Stringer Hanger	18 Gage ASTM A653 SS Grade 33	G185
HDQIF Face Mount Inverted Flange Hanger	14 Gage ASTM A653 SS Grade 40SP	G90
HTC4 Heavy Truss Clip	16 Gage ASTM A653 SS Grade 40SP	G90
JDS Purlin Hanger	18 Gage ASTM A653 SS Grade 33	G90
JLIF Inverted Flange Joist Hanger	18 Gage ASTM A653 SS Grade 40SP	G185
LJC Lateral Joist Connector	18 Gage ASTM A653 SS Grade 33	G185
LJQ Lateral Joist Connector	16 Gage ASTM A653 SS Grade 33	G185
MUS Slant Nail Joist Hanger	18 Gage ASTM A653 SS Grade 40SP	G90
RBC Roof Boundary Clip	20 Gage ASTM A653 SS Grade 40SP	G90

¹ Corrosion protection is a zinc coating of sheet steel in accordance to ASTM A 653.

² Steel designated as ASTM A653 SS Grade 40SP in the table above has a specified minimum yield strength, F_y , of 42 ksi (290 MPa), and a specified minimum tensile strength, F_u , of 56 ksi (386 MPa).

³ Steel designated as ASTM A653 SS Grade 33 in the table above has a specified minimum yield strength, F_y , of 33 ksi (228 MPa) and a specified minimum tensile strength, F_u , of 45 ksi (310 MPa).