



Report Number: 0200

Issued: 02/2011

Expires: 02/2013

Revised: 02/06/2012

DIVISION: 06 00 00–WOOD, PLASTICS AND COMPOSITES
Section: 06 05 23–Wood, Plastic and Composite Fastenings

REPORT HOLDER:
UNITED STEEL PRODUCTS COMPANY
14305 SOUTHCROSS DRIVE, SUITE 200
BURNSVILLE, MINNESOTA 55306
(952) 898-8772
www.uspconnectors.com

EVALUATION SUBJECT:
USP Hold-Down and Tension-Tie Connectors

1.0 EVALUATION SCOPE

1.1 Compliance with the following codes

- 2009 International Building Code (IBC)
- 2009 International Residential Code (IRC)
- 2006 International Building Code (IBC)
- 2006 International Residential Code (IRC)

1.2 Evaluated in accordance with

- ICC-ES AC155, Acceptance Criteria for Hold-Downs Attached to Wood Members approved June 2010.

1.3 Property evaluated

- Structural

2.0 USES

The USP holddown connectors described in this report are used as wood framing anchorage, such as to connect wood posts to concrete foundations or to connect an upper-story wood post to a lower-story supporting wood post, in accordance with the 2009 IBC Sections 2304.9.3, 2305.1, 2308.9.3.1, 2308.9.3.2, AF&PA SDPWS-2008 (Special Design Provisions for Wind and Seismic) Sections 4.3.6.4.2 and 4.3.6.1.2 (the 2006 IBC Sections 2304.9.3, 2305.1, 2305.3.2, 2305.3.7, 2305.3.8.2.4, and 2308.9.3.1); and are used as anchorage of concrete and masonry walls to structural wood elements to provide lateral support for the walls as required by IBC Section 1604.8. The holddown connectors may also be used in structures

regulated under the IRC, when an engineered design is submitted in accordance with Section R301.1.3 of the IRC.

3.0 GENERAL DESCRIPTION

3.1 Product information

3.1.1 DTB-TZ Deck Tie Bracket Holddown: The DTB-TZ deck tie bracket holddown consists of a main structural steel component with prepunched holes for installation of USP WS15-GC wood screws used to connect the holddown to the wood member, and a base component that provides a seat for an anchor rod/bolt nut, as shown in Figure 1. See Table 1 and Figure 1 for product dimensions, fastener schedule, allowable loads and typical installation details.

3.1.2 HTT Tension Tie Holddowns: The HTT tension tie holddowns consist of a steel strap with prepunched holes for installation of nails used to connect the holddown to the wood member, and a base component that provides a seat for an anchor rod/bolt nut, as shown in Figure 2. See Table 2 and Figure 2 for stock numbers, product dimensions, fastener schedule, allowable loads and typical installation details.

3.1.3 LTS and LTTI Tension Tie Holddowns: The LTS and LTTI tension tie holddowns consist of a steel strap with prepunched holes for installation of nails or bolts used to connect the holddown to the wood member, and a base component that provides a seat for an anchor rod/bolt nut, as shown in Figure 3. See Table 7 for steel thickness of various components making up the LTS and LTTI tension tie holddowns. See Table 3 and Figure 3 for stock numbers, product dimensions, fastener schedule, allowable loads and typical installation details.

3.1.4 PHD and PHDA Holddowns: The PHD and PHDA holddowns consist of a main structural steel component with prepunched holes for installation of USP WS3 wood screws used to connect the holddown to the wood member, and a base plate component that provides a seat for an anchor rod/bolt nut, as shown in Figure 4. The USP WS3 wood screws are provided with the PHD and PHDA holddowns. See Table 7 for the steel thickness of various components making up the PHD and PHDA holddowns. See Table 4 and Figure 4 for stock numbers, product dimensions, fastener schedule, allowable loads and typical installation details.

Report Number: 0200

Issued: 02/2011

Expires: 02/2013

Revised: 02/06/2012

3.1.5 UPHD Holdowns: The UPHD holdowns consist of a main structural steel component with prepunched holes for installation of USP WS3 wood screws used to connect the holdown to the wood member, and a base plate component that provides a seat for an anchor rod/bolt nut, as shown in Figure 5. The USP WS3 wood screws are provided with the UPHD holdowns. See Table 7 for the steel thickness of various components making up the UPHD Holdowns. See Table 5 and Figure 5 for stock numbers, product dimensions, fastener schedule, allowable loads and typical installation details.

3.1.6 TD and TDX Holdowns: The TD and TDX holdowns consist of a main structural steel component with prepunched holes for installation of bolts used to connect the holdown to the wood member, and a base component that provides a seat for an anchor rod/bolt nut, as shown in Figure 6. See Table 7 for the steel thickness of various components making up the TD and TDX holdowns. See Table 7 and Figure 6 for stock numbers, product dimensions, fastener schedule, allowable loads and typical installation details.

3.2 Materials

3.2.1 Steel: The specific types of steel and corrosion protection for each product are described in Table 7 of this report. Minimum steel base-metal thicknesses for the different gages are shown in the following table:

GAGE NO.	DESIGN BASE-METAL THICKNESS (inch)	MINIMUM BASE-METAL THICKNESS (inch)
18	0.046	0.044
16	0.058	0.055
14	0.074	0.070
12	0.104	0.099
10	0.136	0.129
7	0.180	0.171
3	0.250	0.238

For SI: 1 inch = 25.4 mm.

3.2.2 Wood: Wood members with which the holdowns are used must be sawn lumber with a minimum specific gravity of 0.50, or approved structural engineered lumber (structural composite lumber, alternative strand lumber, or prefabricated wood I-joists) with a minimum equivalent specific gravity of 0.50, unless otherwise noted in the applicable table within this report. Wood members must have a moisture content not exceeding 19 percent (16 percent for structural engineered lumber), except as noted in Section 4.1. For connectors installed

with nails or WS wood screws, the thickness of each wood member must be sufficient such that the specified fasteners do not protrude through the opposite side of the member. For installations in structural engineered lumber, minimum allowable nail or screw spacing and end distance, as specified in the applicable evaluation report for the structural engineered lumber, must be met. Refer to 3.2.7 for issued related to treated wood.

3.2.3 Fasteners and Threaded Rod: Required fastener types and sizes for use with the USP structural connectors described in this report are specified in this section and Tables 1 through 6. Fasteners and threaded rods must comply with Sections 3.2.4 through 3.2.6, as applicable.

3.2.4 Bolts and Threaded Rod: At a minimum, bolts and threaded rods must comply with ASTM A 307 Grade C or A 36 and must have a tensile strength of 58,000 lbf/in² (310 MPa). Bolt and threaded rod diameters must be specified in the applicable tables of this report.

3.2.5 WS Wood Screws: WS3 wood screws are provided with the PHD, PHDA and UPHD series holdowns. WS3 wood screws have a major diameter of 0.242 inch (6.1 mm) and a length of 3.0 inches (76.2 mm) and a minimum bending yield strength of 180,000 psi. WS15-GC wood screws are provided with DTB-TZ holdowns. WS15-GC woods screws have a major diameter of 0.242 inch (6.1 mm) and a length of 1½ inches (38.1 mm) and a minimum bending yield strength of 180,000 psi.

3.2.6 Nails: Nails used for connectors described in this report must comply with material requirements, physical properties, tolerances, workmanship, protective coating and finishes, and packaging and package marking requirements specified in ASTM F 1667; and must have lengths, diameters and bending yield strengths, F_{yb} , as shown in the following table:

FASTENER DESIGNATION	FASTENER LENGTH (inches)	SHANK DIAMETER (inch)	MINIMUM REQUIRED F_{yb} (lbf/in ²)
10d x 1½	1.5	0.148	90,000
10d common	3.0	0.148	90,000
16d common	3.5	0.162	90,000

For SI: 1 inch = 25.4 mm, 1 psi = 6.89 kPa.

Report Number: 0200

Issued: 02/2011

Expires: 02/2013

Revised: 02/06/2012

3.2.7 Use in Treated Wood: Connectors and fasteners used in contact with preservative-treated or fire-retardant-treated wood must comply with IBC Section 2304.9.5, 2006 IRC Section R319.3 or 2009 IRC Section R317.3. The lumber treater or the report holder (United Steel Products Company), or both, should be contacted for recommendations on the appropriate level of corrosion resistance to specify for the connectors and fasteners as well as the connection capacities of the fasteners used with the specific proprietary preservative-treated or fire-retardant-treated lumber.

4.0 DESIGN AND INSTALLATION

4.1 Design

4.1.1 Holdown Assembly: The allowable loads shown in Tables 1 through 6 of this report are for holdown assemblies consisting of the following components: (1) holdown device; (2) an anchor bolt/rod attached to the seat of the device; (3) a wood member having minimum specified dimensions and properties; (4) fasteners of a quantity, type and size used to attach the holdown device to the wood member; and (5) bearing plates or washers. The allowable loads for these assemblies are based on allowable stress design (ASD) and include the load duration factor, C_D , corresponding to the applicable loads, and the group action factor, C_g , where applicable, in accordance with the National Design Specification (NDS) for Wood Construction.

Allowable strength values are applicable for designs complying with Sections 12.10 and 12.11.2 of ASCE 7-05.

Tabulated allowable loads are for holdowns connected to wood used under continuously dry interior conditions, and where sustained temperatures are 100°F (37.8°C) or less.

When holdowns are fastened to wood that will experience sustained exposure to temperatures exceeding 100°F (37.8°C), the allowable loads shown in Tables 1 through 6 of this report must be adjusted by the temperature factor, C_t , specified in the NDS.

When holdowns are fastened to wood having a moisture content greater than 19 percent (16 percent for engineered lumber), or where wet service is expected,

the allowable loads shown in Tables 1 through 6 of this report must be adjusted by the wet service factor, C_M , as specified in the NDS for lateral loads on dowel-type fasteners.

Hold-downs (tie-downs) in contact with chemically treated preservative wood are subject to the approval of the code official, since the effects of corrosion of metal in contact with chemically treated wood on the structural performance of the devices is outside the scope of this report.

Wood members to which the holdowns are attached must be checked for allowable capacity at the critical net section for total combined stresses in accordance with the NDS, where applicable. Total combined stresses at the critical net section consist of flexural stress due to holdown eccentricities relative to the centroid of the connected wood member (M_{xx} and M_{yy}) combined with axial tension (T) stress. The distance between the centerline of the nearest fastener hole and the edge or end of a device is shown in Table 8.

When using the basic load combinations in accordance with IBC Section 1605.3.1, the tabulated allowable loads for the hold-down (tie-down) shall not be increased for wind or earthquake loading. When using the alternate basic load combinations in IBC Section 1605.3.2 that include wind or earthquake loads, the tabulated allowable loads for the hold-down (tie-down) shall not be increased by 33-1/3 percent, nor shall the alternative basic load combinations be reduced by a factor of 0.75.

Where design load combinations include earthquake loads or effects, story drifts of the structure must be determined in accordance with Section 12.8.6 of ASCE 7-05 by using strength-level seismic forces without reduction for ASD. The deflection of a shear wall restrained from overturning by holdowns installed in accordance with this report is calculated using Equation 23-2 shown in Section 2305.3.2 of the 2006 IBC, Section 2305.3 for the 2009 IBC, or Equation 4.3-1 shown in Section 4.3.2 on ANSI/AF&PA SDPWS-2008 (Special Design Provisions for Wind and Seismic). The total deflection values, Δ_{all} and Δ_s , at ASD-level and strength-level forces, respectively, for holdown assemblies shown in Tables 1 through 6 of this report include all sources of holdown assembly elongation, such as fastener slip, holdown device extension and rotation, and anchor rod elongation where the unbraced length of the rod is a



Report Number: 0200
Issued: 02/2011
Expires: 02/2013
Revised: 02/06/2012

maximum of 5 inches (127 mm). The contribution of the holddown anchor rod elongation in the total elongation (deflection) of the holddown assembly needs to be considered when the actual diameter, length, or ASTM steel specification of the anchor rod differs from that described in this report.

Please note: When seismic governs, the symbol Δ_s as used in this report refers to the symbol d_a in Section 2305.3.2 of the 2006 IBC, 2305.3 of the 2009 IBC and to the symbol Δ_a in Section 4.3.2 of ANSI/AF&PA SDPWS-2008.

4.1.2 Anchorage to Concrete or Masonry: Adequate embedment length and anchorage details, including edge and end distances, must be determined by a licensed design professional in accordance with Chapter 19 or 21 of the IBC, as applicable, for design of anchorage to concrete and masonry structural members.

Where design load combinations include earthquake loads or effects, the design strength of the anchorage to concrete must be determined in accordance with Section 1912 of the IBC, except for detached one- and two-family dwellings, assigned to Seismic Design Category A, B or C, or located where the mapped short-period spectral response acceleration, S_s , is less than 0.4g as stated in Section 1613.1 of the IBC.

4.2 Installation

Installation of the holddown connectors must be in accordance with this evaluation report and the manufacturer's published installation instructions. In the event of a conflict between this report and the manufacturer's published installation instructions, this report governs.

When hold-down (tie-down) devices are attached to multi-ply framing members, the connection between laminations shall be designed in accordance with Section 15.3 of the AF&PA National Design Specification for Wood Construction 2005 Edition.

4.3 Special Inspection

4.3.1 IBC: Periodic special inspection is required for installation of connectors described in this report that are designated as components of the seismic-force-resisting system for structures in Seismic Design Categories C,

D, E or F in accordance with IBC Section 1707.3 or 1707.4, with the exception of those structures that qualify under the Exceptions to Section 1704.1.

Special inspections for anchor bolts in concrete or masonry shall be conducted in accordance with Section 1704.4 or 1704.5 of the IBC.

Periodic special inspection shall be conducted when the product series are components within the main wind-force-resisting system of structures constructed in areas listed in the 2009 IBC Section 1706.

4.3.2 IRC: Special inspections are not required for connectors used in structures regulated under the IRC.

5.0 CONDITIONS OF USE

The USP holddown connectors described in this report comply with, or are suitable alternatives to what is specified in, those codes listed in Section 1.0 of this report, subject to the following conditions:

5.1 The connectors must be manufactured, identified and installed in accordance to this report and the manufacturer's published installation instructions. A copy of the manufacturer's published installation instructions must be available at the jobsite at all times during installation.

5.2 Calculations and details showing compliance with this report must be submitted to the code official. The calculations and details must be prepared by a licensed design professional where required by the statutes of the jurisdiction in which the project is to be constructed.

5.3 For compliance with the 2009 IBC, a statement of special inspection shall be prepared by the licensed design professional in responsible charge, and submitted to the code official for approval, where required by Section 1705 of the 2009 IBC.

5.4 For compliance with the 2006 IBC, a quality assurance plan shall be submitted to the code official for approval, where required by Section 1705 or 1706 of the 2006 IBC.

5.5 Connected wood members and fasteners must comply with Sections 3.2 of this report.



Report Number: 0200

Issued: 02/2011

Expires: 02/2013

Revised: 02/06/2012

5.6 Adjustment factors noted in Section 4.1.1 and the applicable codes must be considered, where applicable.

5.7 Use of steel holdowns and fasteners in contact with preservative- or fire-retardant-treated lumber must be in accordance with Section 3.2.7 of this report.

5.8 Anchorage to concrete or masonry structural members must be designed and detailed in accordance with Section 4.1.2 of this report.

5.9 Welded holdowns, identified in Table 7 as being manufactured under a quality control program with third-party inspections, are manufactured at the designated facilities under a quality control program with inspections by PFS Corporation (AA-652).

6.0 EVIDENCE SUBMITTED

Testing and analysis data submitted is in compliance with the ICC Evaluation Service Acceptance Criteria, AC155, Acceptance Criteria for Hold-Downs, (Tie-Downs) Attached to Wood Members effective July 1, 2010. Test results are from laboratories in compliance with ISO/IEC 17025.

7.0 IDENTIFICATION

The holdown devices described in this report are identified by the product model (stock) number, the number of the IAPMO index evaluation report for United Steel Products (ER-0200) which identifies the products listed in this report and by one or more of the following designations: USP or United Steel Products Company. Labels on connectors identified in Table 7 as being manufactured under a quality control program with third-party inspections also bear the name of the third-party inspection agency (PFS Corporation).



IAPMO #0200

A handwritten signature in black ink, appearing to read 'Russ Cheney'.

Technical Director of Evaluation Services

A handwritten signature in black ink, appearing to read 'Russ Cheney'.

CEO, The IAPMO Group

EVALUATION REPORT



Report Number: 0200

Issued: 02/2011

Expires: 02/2013

Revised: 02/06/2012

TABLE 1 - DTB DECK TIE BRACKET HOLDDOWN

STOCK NUMBER	STEEL GAUGE	DIMENSIONS (inches)				FASTENER SCHEDULE					MINIMUM WOOD MEMBER THICKNESS (inches) ⁶	ALLOWABLE LOADS (lbs) ^{3,4}		DEFLECTION AT ALLOWABLE DESIGN LOADS (inches)		STRENGTH LEVEL DEFORMATION Δ_s @ 160% (inches) ⁵
						Bolt ¹		Screws ²				100%	160%	Δ At 100%	Δ At 160%	
		W	L	D	CL	Qty.	Type	Qty.	Size	Designation						
DTB-TZ	14	1 ¹³ / ₁₆	6	2 ¹ / ₄	1 ¹ / ₈	1	1/2	8	1/4" x 1 1/2"	WS15	1 1/2	1835	1835	0.119	0.119	0.245

For SI: 1 inch = 25.4 mm, 1 lbf = 4.45 N, 1 psi = 6.89 kPa

¹Use ASTM A307 bolt or threaded rod with cut washer and nut

²WS15 denotes USP Wood Screw, 1/4" diameter 1-1/2" long

³Allowable loads include a 60% increase for wind or seismic load conditions. No further increase shall be permitted.

⁴Allowable load values of the hold-down (tie-down) device are a measure of the strength of the assembly with a safety factor of 3.0 applied to the lowest maximum test load.

⁵The design of hold-down (tie-down) devices used in series shall account for the cumulative deformation of all hold-downs (tie-downs) within said series.

⁶The design of the framing member is outside of the scope of this report. The designer should select a framing member(s) that is sized so that the minimum end distance of 2-1/2" and edge distance of 5/8" for the fasteners, as recommended in the NDS, are met and with strength properties that resist the anticipated loads.

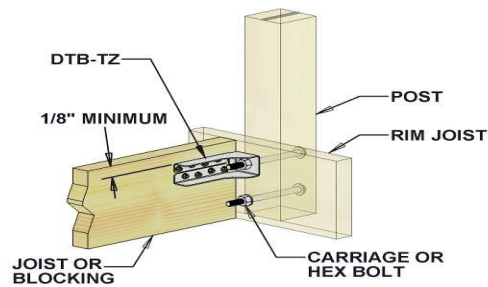
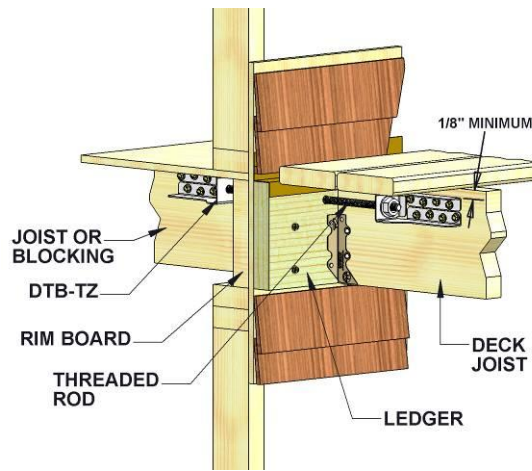
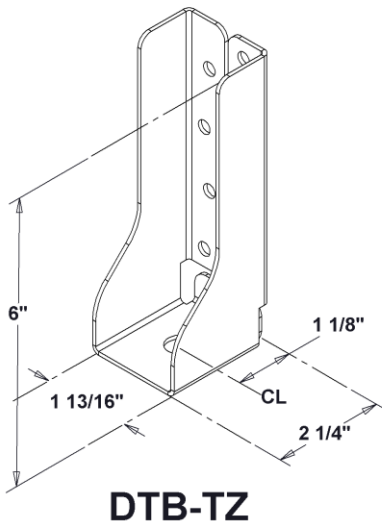

FIGURE 1 – DBT-TZ DECK TIE BRACKET HOLDDOWNS

EVALUATION REPORT



Report Number: 0200

Issued: 02/2011

Expires: 02/2013

Revised: 02/06/2012

TABLE 2 - HTT TENSION TIE HOLDOWN SERIES

STOCK NO.	STEEL GA.	DIMENSIONS (inches)				FASTENER SCHEDULE ^{1 2 3}				MINIMUM WOOD MEMBER THICKNESS (inches) ⁸	ALLOWABLE LOADS (lbs) ^{4, 6}	DEFLECTION AT ALLOWABLE DESIGN LOADS (inches)	STRENGTH LEVEL DEFORMATION Δ_s (inches) ⁷
		W	L	D	CL	Anchor Bolts ⁵		Nails					
						Qty.	Type	Qty.	Type		160%		
HTT4	12	3	10 ⁷ / ₁₆	2 ³ / ₄	1 ³ / ₈	1	5/8	18	NA9	1 ¹ / ₂	2715	0.095	0.123
									10dC	3	3295	0.098	0.133
									16dx2-1/2"	3	4465	0.143	0.192
HTT5	12	3	13 ¹⁵ / ₁₆	2 ³ / ₄	1 ³ / ₈	1	5/8	28	NA9	1 ¹ / ₂	3225	0.088	0.117
									10dC	3	4745	0.122	0.193
									16dx2-1/2"	3	5430	0.141	0.231

For SI: 1 inch = 25.4 mm, 1 lbf = 4.45 N, 1 psi = 6.89 kPa

¹A NA9 nail is 1¹/₂" inches long and 0.148 inches in diameter.

²A 10dC nail refers to a 10d Common nail that is 3 inches long and 0.148 inches in diameter.

³A 16dx2-1/2" nail is 2¹/₂ inches long and 0.162 inches in diameter.

⁴Allowable loads include a 60% increase for wind or seismic load conditions. No further increase shall be permitted.

⁵The designer must specify anchor bolt type, length and embedment depth.

⁶Allowable load values of the hold-down (tie-down) device are a measure of the strength of the assembly with a safety factor of 3.0 applied to the lowest maximum test load.

⁷The design of hold-down (tie-down) devices used in series shall account for the cumulative deformation of all hold-downs (tie-downs) within said series.

⁸The design of the framing member is outside of the scope of this report. The designer should select a framing member(s) that is sized so that the minimum end distance of 1-5/8" and edge distance of 7/16" for the fasteners, as recommended in the NDS, are met and with strength properties that resist the anticipated loads.

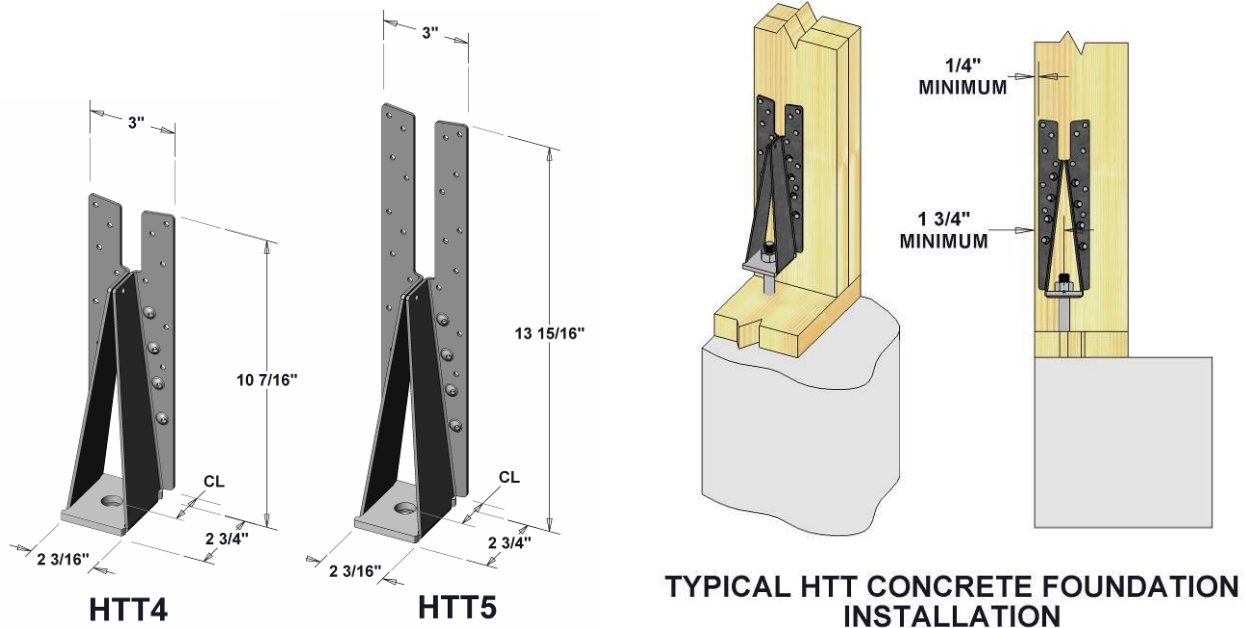

FIGURE 2 – HTT TENSION TIE HOLDOWNS

EVALUATION REPORT



Report Number: 0200

Issued: 02/2011

Expires: 02/2013

Revised: 02/06/2012

TABLE 3 - LTS & LTTI TENSION TIE HOLDDOWN SERIES

STOCK NUMBER	STEEL GAGE		DIMENSIONS (inches)				FASTENER SCHEDULE ^{1,2,3}						MINIMUM WOOD MEMBER THICKNESS (inches) ⁹	ALLOWABLE LOADS (lbs) ^{4,7}		DEFLECTION AT ALLOWABLE DESIGN LOADS (inches)	STRENGTH LEVEL DEFORMATION Δs (inches) ⁸	
	Strap	Plate	W	L	D	CL	Anchor Bolts ⁵		Nails		Bolts			For Bolted Configuration ⁶				
							Qty.	Type	Spacing	Qty.	Type	Qty.			Diameter (inches)			For Nailed Configuration
LTS19	16	3	1 3/4	22 1/4	3	1 1/2	1	3/4	2 1/2	8	10dC	--	--	3	1205	--	0.132	0.206
LTS20	12	3	2	20	3	1 1/2	1	1/2	3 3/4	10	10d x 1 1/2" 16dC	--	--	1 1/2 3	1100 1105	--	0.060 0.064	0.231 0.245
LTS20B	12	3	2	20	3	1 1/2	1	3/4	3 3/4	10	10d x 1 1/2" 16dC	2	1/2	1 1/2 3	1100 1105	1175	0.128	0.234
LTTI31	18	3	3 3/4	31	2 5/8	1 3/8	1	5/8	3	18	10d x 1 1/2"	--	--	1 1/2	2805	--	0.175	0.234

For SI: 1 inch = 25.4 mm, 1 lbf = 4.45 N, 1 psi = 6.89 kPa

¹A 10d x 1 1/2" nail is 1 1/2 inches long and 0.148 inches in diameter.

²A 10d Common nail is 3 inches long and 0.148 inches in diameter.

³A 16d Common nail is 3 1/2 inches long and 0.162 inches in diameter.

⁴Allowable loads include a 60% increase for wind or seismic load conditions. No further increase shall be permitted.

⁵The designer must specify anchor bolt type, length and embedment depth.

⁶Bolts connecting the LTS20B require a minimum length of 1-1/2" in vertical member for listed load.

⁷Allowable load values of the hold-down (tie-down) device are a measure of the strength of the assembly with a safety factor of 3.0 applied to the lowest maximum test load.

⁸The design of hold-down (tie-down) devices used in series shall account for the cumulative deformation of all hold-downs (tie-downs) within said series.

⁹The design of the framing member is outside of the scope of this report. The designer should select a framing member(s) that is sized so that the minimum end distance of 1-5/8" and edge distance of 7/16" for the fasteners, as recommended in the NDS, are met and with strength properties that resist the anticipated loads.

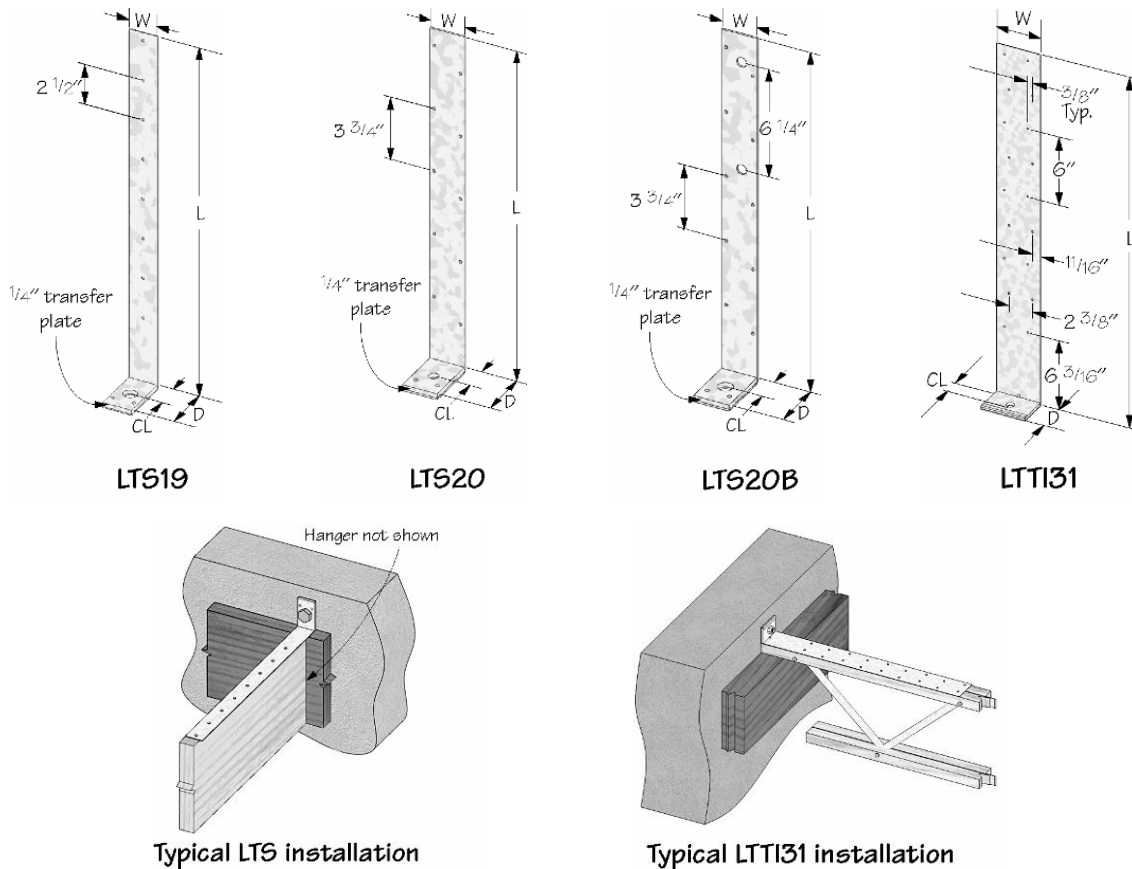

FIGURE 3 – LTS and LTTI TENSION TIE HOLDDOWNS

EVALUATION REPORT



Report Number: 0200

Issued: 02/2011

Expires: 02/2013

Revised: 02/06/2012

TABLE 4 - PHD & PHDA HOLDDOWN SERIES

STOCK NUMBER	STEEL GAGE	DIMENSIONS (inches)				FASTENER SCHEDULE				MINIMUM WOOD MEMBER THICKNESS (inches) ⁶	ALLOWABLE LOADS (lbs) ^{2,3}	DEFLECTION AT ALLOWABLE DESIGN LOADS (inches)	STRENGTH LEVEL DEFORMATION (inches) ⁴
		W	H	D	CL	Anchor Bolts ⁵		Wood Screws ¹					
						Qty.	Dia (in)	Qty.	Type				
PHD2	12	3 1/4	7 1/2	3	1 3/8	1	5/8	10	WS3	3	4,815	0.058	0.096
PHD5	12	3 1/4	10 7/8	3	1 3/8	1	5/8	14	WS3	3	5,540	0.056	0.085
PHD6	12	3 1/4	13 7/16	3	1 3/8	1	7/8	18	WS3	3	7,295	0.061	0.105
PHD8	12	3 1/4	16 1/2	3	1 3/8	1	7/8	24	WS3	3	8,185	0.062	0.111
PHD2A	14	3 1/4	7 3/4	2 5/8	1 3/8	1	5/8	6	WS3	3	3,215	0.155	0.191
PHD4A	14	3 1/4	9 3/4	2 5/8	1 3/8	1	5/8	10	WS3	3	5,215	0.137	0.177
PHD5A	14	3 1/4	11 11/16	2 5/8	1 3/8	1	5/8	14	WS3	3	6,525	0.135	0.177
PHD8A	10	3 1/4	15 1/2	2 5/8	1 3/8	1	7/8	20	WS3	3	8,540	0.079	0.110

For SI: 1 inch = 25.4 mm, 1 lbf = 4.45 N, 1 psi = 6.89 kPa

¹WS3 denotes USP Wood Screw, 1/4" diameter 3" long

²Allowable loads include a 60% increase for wind or seismic load conditions. No further increase shall be permitted.

³Allowable load values of the hold-down (tie-down) device are a measure of the strength of the assembly with a safety factor of 3.0 applied to the lowest maximum test load.

⁴The design of hold-down (tie-down) devices used in series shall account for the cumulative deformation of all hold-downs (tie-downs) within said series.

⁵The designer must specify anchor bolt type, length and embedment depth.

⁶The design of the framing member is outside of the scope of this report. The designer should select a framing member(s) that is sized so that the minimum end distance of 2-1/2" and edge distance of 5/8" for the fasteners, as recommended in the NDS, are met and with strength properties that resist the anticipated loads.

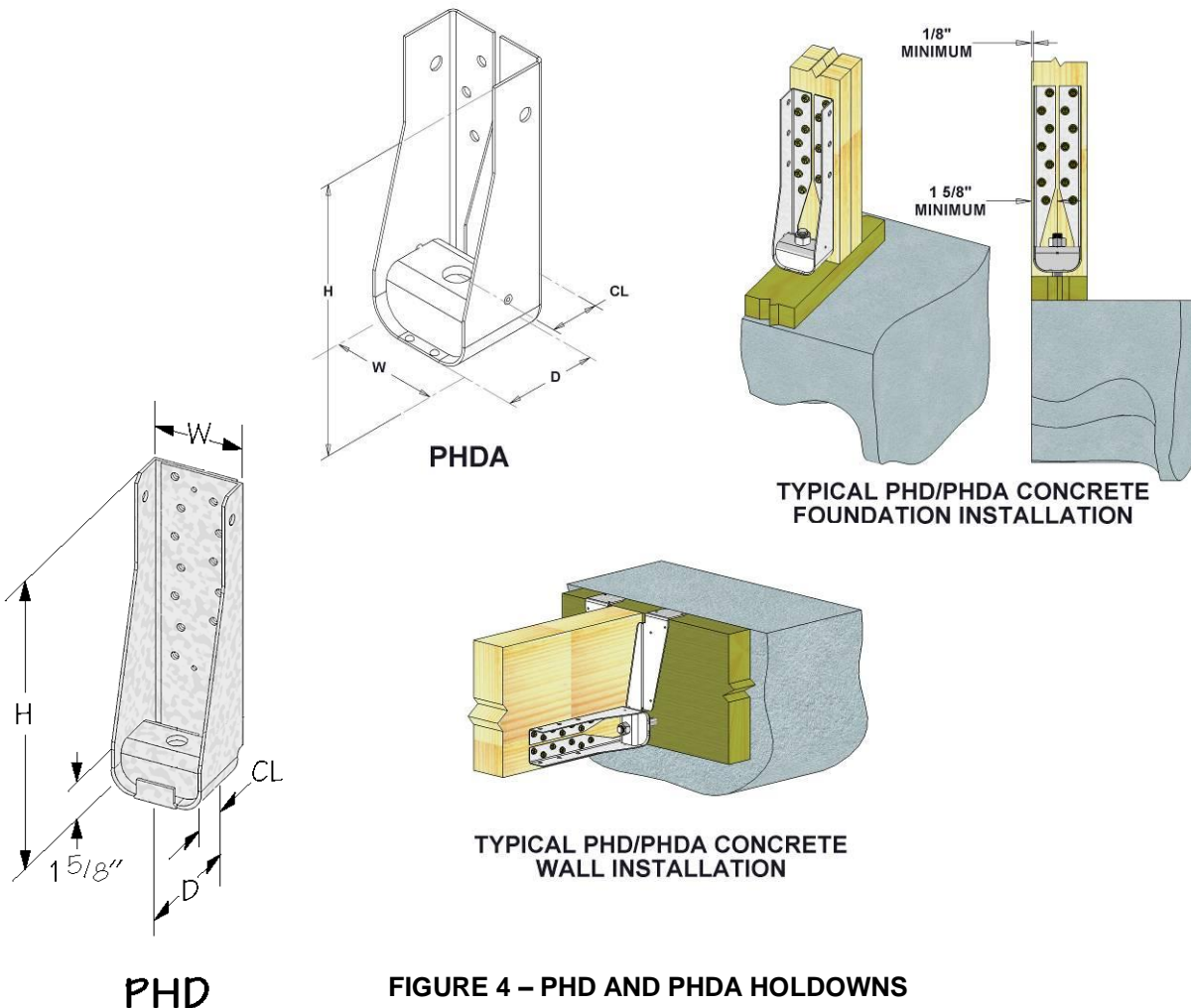

EVALUATION REPORT



Report Number: 0200

Issued: 02/2011

Expires: 02/2013

Revised: 02/06/2012

TABLE 5 - UPHD HOLDOWN SERIES

STOCK NUMBER	STEEL GAGE	DIMENSIONS (inches)				FASTENER SCHEDULE				MINIMUM WOOD MEMBER THICKNESS (inches) ⁶	ALLOWABLE LOADS (lbs) ^{2,3}	DEFLECTION AT ALLOWABLE DESIGN LOADS (inches)	STRENGTH LEVEL DEFORMATION (inches) ⁴
		W	H	D	CL	Anchor Bolts ⁵		Wood Screws ¹					
						Qty.	Dia (in)	Qty.	Type				
UPHD8	10	3 ¹ / ₄	17 ¹ / ₄	3 ¹ / ₈	1 ³ / ₈	1	7 ⁷ / ₈	24	WS3	3.5	9,165	0.075	0.100
UPHD9	10	3 ¹ / ₄	17 ¹ / ₄	3 ¹ / ₂	1 ¹ / ₂	1	1	24	WS3	5.5	11,270	0.057	0.077
UPHD11	7	3	15 ¹ / ₈	3 ¹ / ₂	1 ¹ / ₂	1	1	24	WS3	5.5	14,395	0.077	0.106
UPHD14	7	3	18 ³ / ₄	3 ¹ / ₂	1 ¹ / ₂	1	1	30	WS3	5.5	16,695	0.082	0.109

For SI: 1 inch = 25.4 mm, 1 lbf = 4.45 N, 1 psi = 6.89 kPa

¹WS3 denotes USP Wood Screw, 1/4" diameter 3" long

²Allowable loads include a 60% increase for wind or seismic load conditions. No further increase shall be permitted.

³Allowable load values of the hold-down (tie-down) device are a measure of the strength of the assembly with a safety factor of 3.0 applied to the lowest maximum test load.

⁴The design of hold-down (tie-down) devices used in series shall account for the cumulative deformation of all hold-downs (tie-downs) within said series.

⁵The designer must specify anchor bolt type, length and embedment depth.

⁶The design of the framing member is outside of the scope of this report. The designer should select a framing member(s) that is sized so that the minimum end distance of 2-1/2" and edge distance of 5/8" for the fasteners, as recommended in the NDS, are met and with strength properties that resist the anticipated loads.

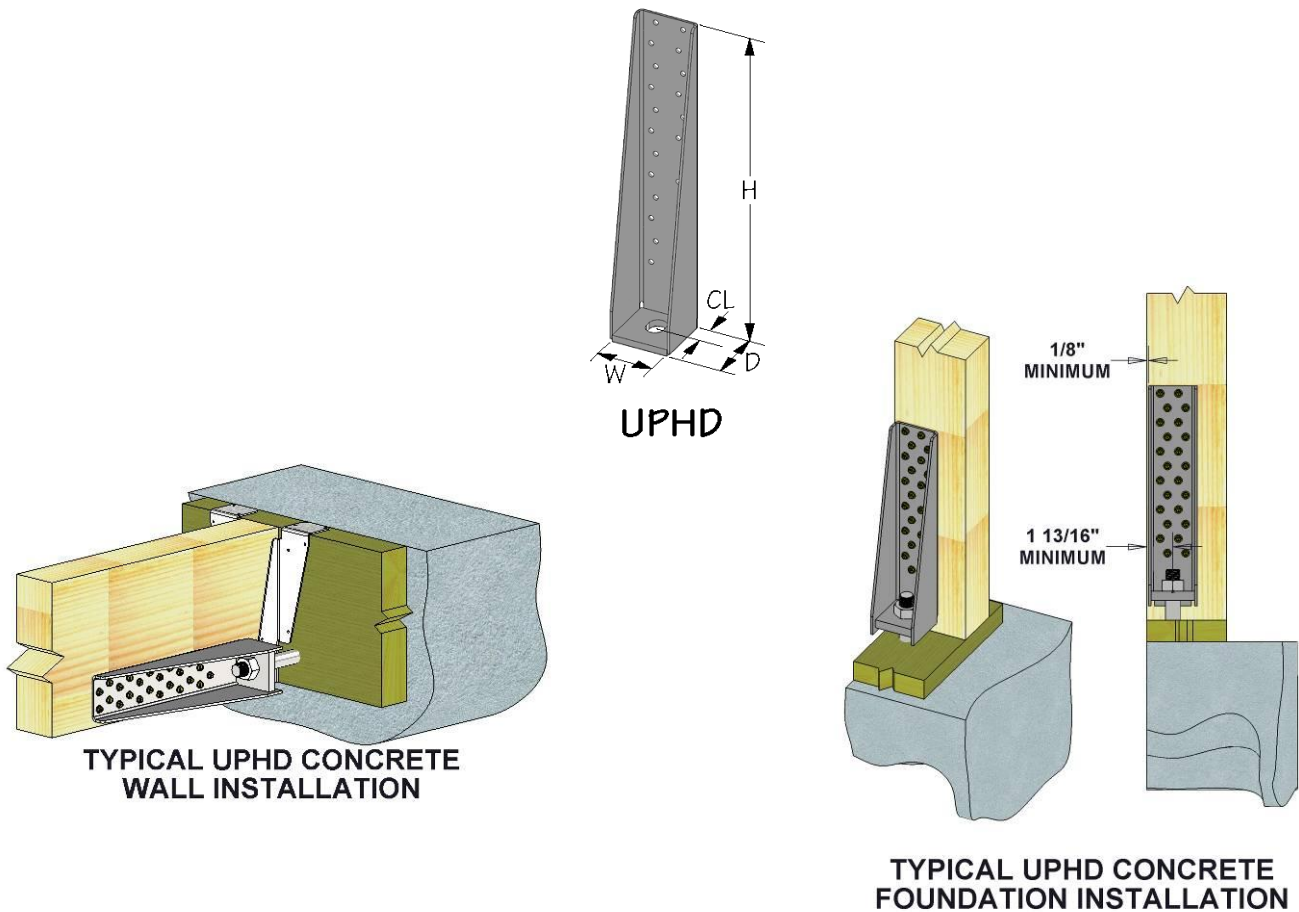

FIGURE 5 - UPHD HOLDDOWNS

EVALUATION REPORT



Report Number: 0200

Issued: 02/2011

Expires: 02/2013

Revised: 02/06/2012

TABLE 6 - TDX & TD Holddown Series

STOCK NUMBER	STEEL GAGE	DIMENSIONS (inches)				FASTENER SCHEDULE					LENGTH OF BOLT IN VERTICAL MEMBER (inches) ⁶	ALLOWABLE LOADS (lbs) ^{2,3}	DEFLECTION AT ALLOWABLE DESIGN LOADS (inches)	STRENGTH LEVEL DEFORMATION Δ_s (in) ⁴
						Anchor Bolts ⁵		Bolts ¹						
		W	H	D	CL	Qty.	Type	Min. End Distance	Qty.	Type				
TDX2	12	2 ¹ / ₁₆	8 ¹ / ₈	2 ³ / ₄	1 ¹ / ₂	1	5 ⁵ / ₈	4 ¹ / ₂	2	5 ⁵ / ₈	1 ¹ / ₂	1910	0.150	0.186
											3	2345	0.167	0.218
											3 ¹ / ₂	3130	0.140	0.196
											5 ¹ / ₂	3130	0.140	0.196
TD5	7	3	6 ³ / ₈	3 ³ / ₄	2 ¹ / ₈	1	3 ³ / ₄	5 ¹ / ₄	2	3 ³ / ₄	1 ¹ / ₂	2405	0.122	0.160
											3	4040	0.140	0.246
											3 ¹ / ₂	4040	0.140	0.246
											5 ¹ / ₂	4040	0.140	0.246
TD7	3	3 ³ / ₈	11 ⁷ / ₈	3 ⁵ / ₈	2 ¹ / ₈	1	1 ¹ / ₈	6 ¹ / ₈	3	7 ⁷ / ₈	1 ¹ / ₂	4600	0.095	0.117
											3	8195	0.125	0.165
											3 ¹ / ₂	9420	0.139	0.188
											5 ¹ / ₂	10510	0.152	0.213
TD9	3	3 ³ / ₈	16 ¹ / ₂	4 ¹ / ₄	2 ¹ / ₈	1	1 ¹ / ₈	7	3	1	3	9330	0.146	0.184
											3 ¹ / ₂	10715	0.160	0.208
											4 ¹ / ₂	13370	0.169	0.225
											5 ¹ / ₂	13500	0.170	0.227
TD12	3	3 ¹ / ₂	20 ¹ / ₂	4 ¹ / ₄	2 ¹ / ₈	1	1 ¹ / ₈	7	4	1	3	12070	0.132	0.160
											3 ¹ / ₂	13960	0.142	0.178
											4 ¹ / ₂	16550	0.185	0.240
											5 ¹ / ₂	16550	0.185	0.240
TD15	3	3 ¹ / ₂	25	4 ³ / ₈	2 ¹ / ₈	1	1 ¹ / ₄	7	5	1	3	14505	0.167	0.195
											3 ¹ / ₂	16845	0.178	0.213
											4 ¹ / ₂	17755	0.202	0.239
											5 ¹ / ₂	17755	0.202	0.239

For SI: 1 inch = 25.4 mm, 1 lbf = 4.45 N, 1 psi = 6.89 kPa

¹Bolts shall conform to ASTM A307 Grade A or better.

²Allowable loads include a 60% increase for wind or seismic load conditions. No further increase shall be permitted.

³Allowable load values of the hold-down (tie-down) device are a measure of the strength of the assembly with a safety factor of 3.0 applied to the lowest maximum test load.

⁴The design of hold-down (tie-down) devices used in series shall account for the cumulative deformation of all hold-downs (tie-downs) within said series.

⁵The designer must specify anchor bolt type, length and embedment depth.

⁶The design of the framing member is outside of the scope of this report. The designer should select a framing member(s) that is sized so that the minimum end and edge distances for the fasteners, as specified in the NDS, are met and with strength properties that resist the anticipated loads.

EVALUATION REPORT



Report Number: 0200

Issued: 02/2011

Expires: 02/2013

Revised: 02/06/2012

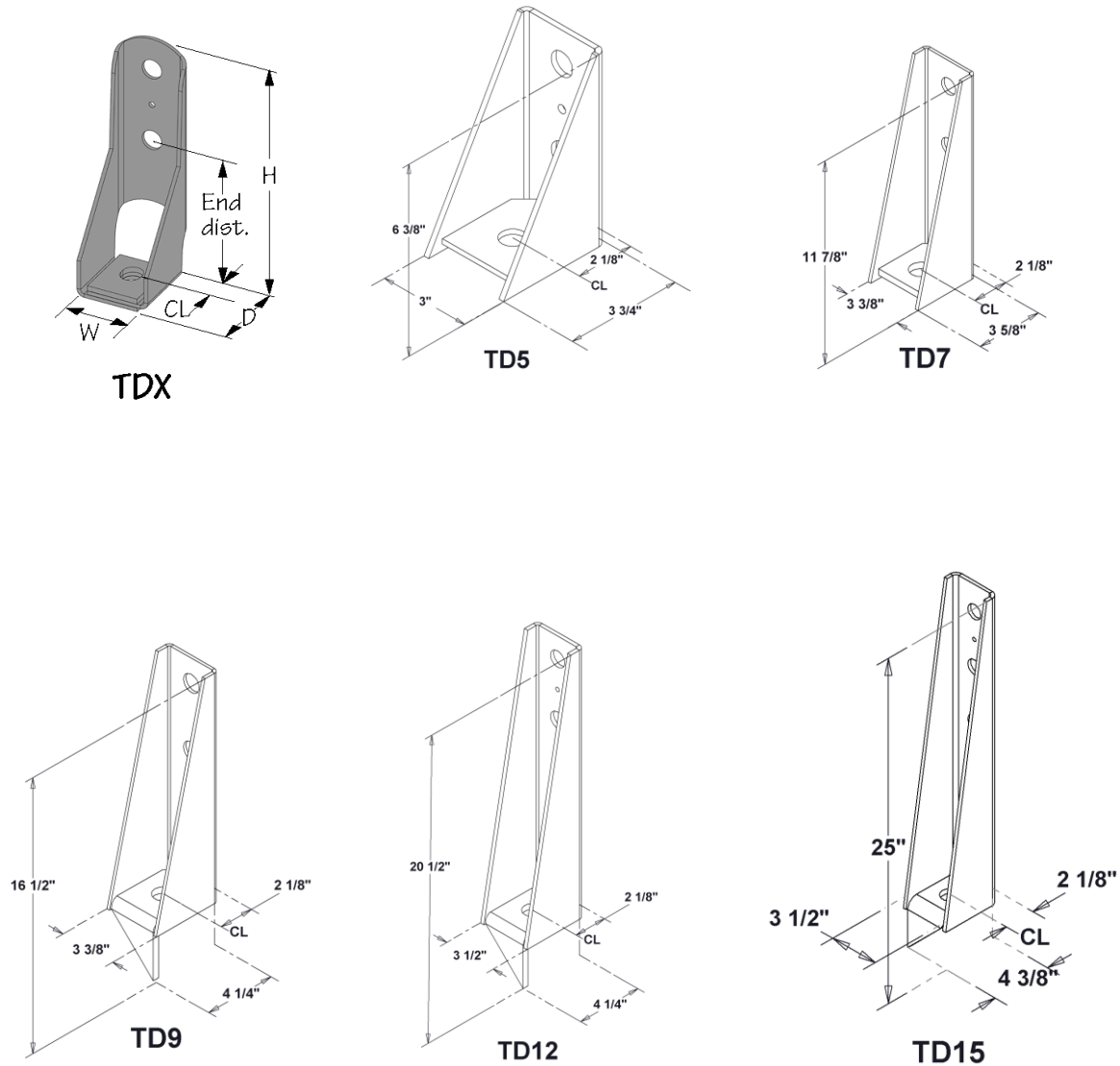

FIGURE 6 – TD AND TDX HOLDDOWNS

EVALUATION REPORT



Report Number: 0200

Issued: 02/2011

Expires: 02/2013

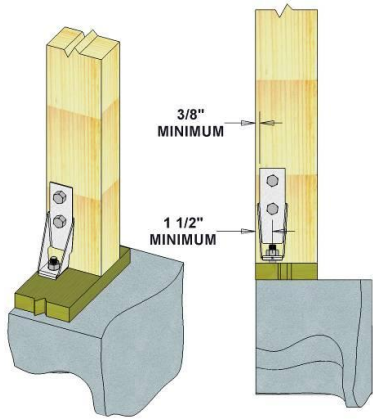

TYPICAL TDX2 CONCRETE FOUNDATION INSTALLATION

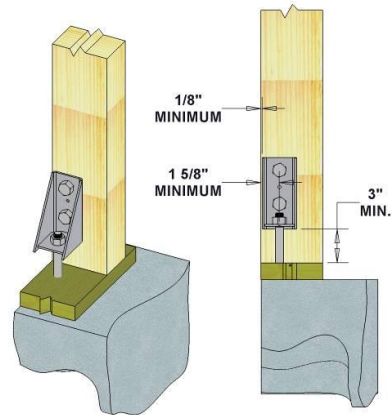

TYPICAL TD5 CONCRETE FOUNDATION INSTALLATION

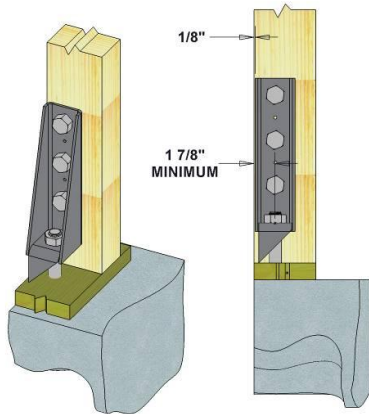

TYPICAL TD9 CONCRETE FOUNDATION INSTALLATION (TD12 & TD15 SIMILAR)

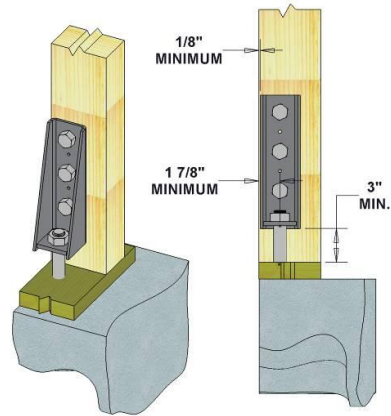

TYPICAL TD7 CONCRETE FOUNDATION INSTALLATION

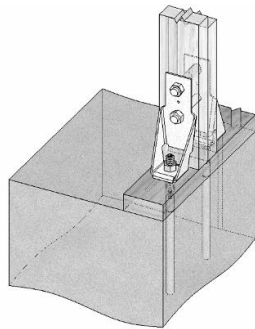

Typical TDX2 back-to-back installation

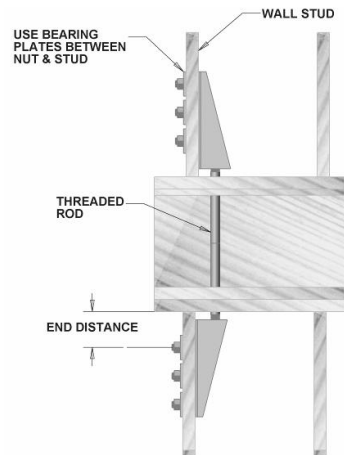

HOLDOWN INSTALLATION BETWEEN FLOORS

FIGURE 6 (Continued) – TD AND TDX HOLDDOWNS

EVALUATION REPORT



Report Number: 0200

Issued: 02/2011

Expires: 02/2013

Revised: 02/06/2012

TABLE 7 - STEEL, TYPE, STRENGTH, AND CORROSION RESISTANCE

PRODUCT	Welded ¹	PART	STEEL GAGE	STEEL SPECIFICATION	SPECIFIED YIELD STRENGTH (lbf/in ²)	SPECIFIED TENSILE STRENGTH (lbf/in ²)	COATING
DTB-TZ		Body	14	ASTM A 653, SS designation Grade 40S	42,000	56,000	G-185 ²
HTT		Body	12	ASTM A 653, SS designation Grade 40S	42,000	56,000	G90 ²
LTS19		Strap	16	ASTM A 653, SS designation Grade 40S	42,000	56,000	G90 ²
		Washer	3	ASTM A 36	36,000	58,000	Painted
LTS20B		Strap	12	ASTM A 653, SS designation Grade 40S	42,000	56,000	G90 ²
		Washer	3	ASTM A 36	36,000	58,000	Painted
LTTI31		Strap	18	ASTM A 653, SS designation Grade 40S	42,000	56,000	G90 ²
		Plate	3	ASTM A 36	36,000	58,000	Painted
PHD		Body	12	ASTM A 653, SS designation Grade 40S	42,000	56,000	G90 ²
		Washer	3	ASTM A 36	36,000	58,000	Painted
PHDA		Body	14	ASTM A 653, SS designation Grade 40S	42,000	56,000	G90 ²
		Washer	3	ASTM A 36	36,000	58,000	Painted
UPHD8	X	Body	10	ASTM A 1011, designation, Grade 33	33,000	45,000	Painted
		Base Plate	1/2" Steel Plate	ASTM A 36	36,000	58,000	Painted
UPHD9	X	Body	10	ASTM A 1011, designation, Grade 33	33,000	45,000	Painted
		Base Plate	5/8" Steel Plate	ASTM A 36	36,000	58,000	Painted
UPHD11 and UPHD14	X	Body	7	ASTM A 1011, designation, Grade 33	33,000	45,000	Painted
		Base Plate	5/8" Steel Plate	ASTM A 36	36,000	58,000	Painted
TD5	X	Body	7	ASTM A 1011, designation, Grade 33	33,000	45,000	Painted
		Base Plate	7	ASTM A 1011, designation, Grade 33	33,000	45,000	Painted
TD7, TD9 TD12 and TD15	X	Body	3	ASTM A 36	36,000	58,000	Painted
		Base Plate	3/8" Steel Plate	ASTM A 36	36,000	58,000	Painted
TDX2-TZ		Body	12	ASTM A 653, SS designation Grade 40S	42,000	56,000	G-185
		Washer	10	ASTM A 653, SS designation Grade 33	33,000	45,000	G90 ²

For SI: 1 inch = 25.4 mm, 1 psi = 6.89 kPa.

¹ Products are factory welded at the USP manufacturing facilities in Largo, FL; Livermore, CA; and Montgomery, MN under a quality control program with third-party inspections by PFS Corporation (PFS).

² Corrosion protection is a zinc coating of sheet steel in accordance to ASTM A 653.

Table 8: Device Edge and End Distances

Product	Edge Distance ¹ (in)	End Distance ² (in)
DTB-TZ	7/16	1-1/4
HTT Series	1/4	3
LTS19	7/8	4-5/16
LST20	1/4	2-7/8
LST20B	1/4	2-7/8
LTTI31	11/16	6-9/16
PHD2A, PHD4A, PHD5A	1/2	4-1/4
PHD8A	9/16	4-1/4
PHD2	13/16	2-1/8
PHD5, PHD6, PHD8	13/16	3-1/4
UPHD8	3/4	3-3/8
UPHD9	3/4	3-1/8
UPHD11	3/4	3-5/8
UPHD14	3/4	4-1/4
TDX2	1-1/8	4-9/16
TD5	1-1/2	2-1/4
TD7	1-3/4	3-3/8
TD9, TD12, TD15	1-3/4	7

¹ The distance between the centerline of the nearest fastener hole and the edge of the device.

² The distance between the centerline of the nearest fastener hole and the edge of the device.